BELARUS
1523/1523B
1523.3/1523B.3

1523 – 0000010 PЭ

OPERATING MANUAL

The Operating Manual has been compiled by engineer УКЭР-1, M.V.Gutko with the participation of the leading specialists of the УКЭР-1 of the Minsk Tractor Works Republican Unitary Enterprise

Editor-in-chief: Director of the Scientific Research Centre
Chief Designer I.N.Uss

Supervisor for the Issue: Chief of КБ ЭД, O.N. Natalevich

The Operating Manual provides a brief description of, and specifications for the BELARUS-1523/1523B/1523.3/1523B.3 tractors manufactured by the Minsk Tractor Works. The basic rules of operation of the machines are stated and the information for adjustment and maintenance of them is provided.

The Manual is intended for tractor drivers operating the BELARUS tractors.

In view of the MTW Production Association's policy of pursuing the constant improvement of the products manufactured, the design of individual component parts may be subjected to modifications not covered by this edition. For more details, please, contact your BELARUS dealer.

TABLE OF CONTENTS

	Page
TO THE OPERATORS' ATTENTION	3
INTRODUCTION	4
INTERNATIONAL SYMBOLS	5
SAFETY REQUIREMENTS	7
BRIEF DESCRIPTION	15
TECHNICAL DATA	19
DRIVE CONTROLS AND INSTRUMENTATION	27
CONSTRUCTION AND OPERATION	57
Engine	57
Clutch	72
Gearbox	80
Creeper	92
Rear Axle	96
Rear Power Takeoff	101
Front Power Takeoff	104
Front Driving Axle	108
Brakes	119
Pneumatic Actuator of the Trailer Brakes	132
Hydrostatic Power Steering	135
Running Gears. Tractor Wheels	143
Hydraulic Lift Linkage	147
Rear Hitch Linkage	162
Front Hitch Linkage	165
Cab Ventilation and Heating System	166
Cab Heating and Air-Conditioning System	167
Electric Equipment	172
TRACTOR PRE-OPERATION	174
AGGREGATING THE TRACTOR WITH AGRICULTURAL MACHINES AND IMPLEMENTS	182
TROUBLESHOOTING	215
TRACTOR TRANSPORTATION AND TOWING	241
SCHEDULED MAINTENANCE	242
TRACTOR STORAGE	279
APPENDICES	280

TO THE OPERATORS' ATTENTION:

1. Prior to proceeding to operation of the tractor, read carefully this Manual and strictly follow all the instructions related to operation and maintenance of the tractor.
2. Be sure to run in the tractor for initial 30 hours. Right up to Maintenance Service 1 (125 h), the diesel-engine loading should not exceed 80 % percent of its power rating.
3. Your tractor is equipped with a speed-range type transmission gearbox. The ranges are switched over by means of tooth-type flexible clutches, while the gears within the range are shifted by means of synchronizers.

To engage a range:

- depress the clutch pedal completely and allow the tractor to come to a standstill;
- then gently, without jerks, select the desired range using the range engagement lever;
- release smoothly the clutch pedal.

To engage a gear:

- depress the clutch pedal completely;
- shift the change-over stick smoothly, without jerks, and hold it in this drawn-in position until the gear is fully engaged;
- release smoothly the clutch pedal.

While on move, gear-shifting within the range should only be made during transport mission, running on hard-surfaced or natural, unpaved roads. When a machine-and-tractor rig is operating off-roads (ploughed fields, peat deposit sites, sandy soils, etc.), **NEVER** shift gears because of the inevitable abrupt stopping of the combination. In this case, negotiate such a terrain in a pre-selected gear. Failure to follow the above instructions could result in premature wear of gears and tooth-type flexible clutch splines as well as in synchronizers damage.

IMPORTANT! If, with the clutch pedal completely depressed, changing of ranges and gears is accompanied by excessive gritting sound, call up your local "Belarus" dealer office to rectify the problem immediately.

4. Observe the rules of PTO engagement. When engaging and disengaging the PTO, move the PTO lever smoothly to avoid damage to the shafts, gears and/or PTO tail-piece.
5. The service and parking brakes should be only adjusted with the tractor placed on a level ground, with the engine stopped and the rear wheels chocked in the front and the rear to prevent the tractor from accidental displacement.

Re-equipment and/or modification of the tractor without manufacturer's agreement are prohibited.

INTRODUCTION

This Manual provides the description of the design and contains the basic technical data and rules of operation and maintenance of agricultural power-intensive wheeled tractors BELARUS-1523/1523.3 and BELARUS -1523B/1523B.3 (reversible modified version).

Belarus 1523 tractor is designed in the 4x4 wheel arrangement and can be used for performing various agricultural works and transport operations with mounted, semi-mounted, and trailer-type farm machinery and implements attached, for transporting cargoes and with cargo handling facilities and harvesting machinery complexes as well as for driving stationary farm machines.

Belarus 1523B tractor of a reversible version is designed for a long-term operation in the reversal and notable for a reversal control post comprising an additional steering column, duplicated clutch, brake, and fuel supply controls as well as with a rotatable operator's seat for working in both forward and reverse movement.





Belarus 1523.2* and Belarus 1523B.2* tractors: a modified version of the basic model BELARUS-1523 and BELARUS-1523B equipped with the Д-260.1S2 engine certified according to the TIER-2.











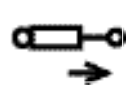

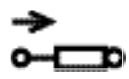
Abbreviations and Conventional Symbols Used

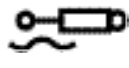
ADL	–	Automatic Differential Lock-up System	АБД
DTC	–	(Engine) Turbocharger	ТКР
FDA	–	Front Driving Axle	ПВМ
FFA	–	Fine Fuel Filter	ФТО
FPTO	–	Front Power Take-Off	ПВОМ
GB	–	Speed Gearbox	КП
HDC	–	Haul-and-Draw Coupler	ТСУ
HLL	–	Hydraulic Lift Linkage	ГНС
HPH	–	High-Pressure Hose	РВД
HSCU	–	Hydrostatic Steering Control Unit	ГОРУ
IMS	–	Inter-Shift Maintenance	ЕТО
IVR	–	Integral Voltage Regulator	ИРН
MS	–	Maintenance	ТО
MTA	–	Machine-and-Tractor Aggregate	МТА
PTO	–	Power Take-off Shaft	ВОМ
P.T.U.	–	Power Take-Up Shaft	ВПМ
PFE	–	Paper Filter Element	БФЭ
RA DL	–	Rear Axle Differential Lock-up	БД ЗМ
RHL	–	Rear Hitch Linkage	ЗНУ
SB	–	Storage Batteries	АКБ
SPTA	–	Spare Parts, Tools and Accessories	ЗИП
TC	–	Transmission Clutch	МС
TDC	–	Top Dead Centre	ВМТ
UCS	–	Universal Control System for farm machinery	УСК

INTERNATIONAL SYMBOLS

The manufacturer uses standard international symbols pertinent to the use of instruments and controls, as follows.

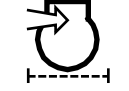
	– Refer to Manual		– Controls manipulation
	– Brake		– Fast
	– Parking brake		– Slow
	– Horn		– Forward
	– Fault signalling		– Backward
	– Fuel		– Storage battery charging
	– Cooling fluid, coolant		– Cab dome light
	– Engine start-up assisting devices		– Marker lamps
	– Engine rpm		– Turn signal
	– Oil pressure in engine		– Trailer turn signal
	– Engine coolant temperature		– High beam
	– OFF/STOP		– Low beam
	– ON/START		– Work floodlights
	– Gradual change		– Differential lock-up
	– Lever – Downwards		– PTO shaft engaged
	– Lever – Upwards		– Front driving axle engaged PTO

- | | | | |
|---|---|---|---|
|  | - "Lift" position of the distributor slide valve |  | - Fan |
|  | - "Drop" position of the distributor slide valve |  | - Windscreen washer |
|  | - "Float" position of the distributor slide valve |  | - Front windscreen wiper |
|  | - Oil pressure in the transmission gearbox |  | - Rear screen wiper |
|  | - Air pressure in the pneumatic system |  | - Oil pressure in the hydrostatic steering control |
|  | - Air filter clogged |  | - Level of braking liquid in the main cylinder reservoirs |
|  | - Diesel start-up (a lamp in the control lamp unit) | | |

SAFETY REQUIREMENTS

1.1. GENERAL

- 1.1.1. Strict observance of the requirements ensures safe operation of the tractor and improves its reliability and durability.
- 1.1.2. Only persons not younger than 17, holders of a tractor driving license, who have been briefed on accident and fire prevention, may be admitted to operate the tractor.
- 1.1.3. Prior to operating the tractor, read carefully the Operator's Manual. Insufficient knowledge of tractor controls and servicing is a potential of likely accidents.

1.2. SAFETY REQUIREMENTS FOR TRANSPORTATION AND DEP-RESERVATION

- 1.2.1. When transporting and handling the tractor, follow the requirements specified under Section 8.
- 1.2.2. When performing the depreservation of the tractor and optional equipment, follow the fire prevention instructions and sanitary requirements when dealing with chemicals, rag wastes and oiled paper.

1.3. REQUIREMENTS FOR TECHNICAL CONDITIONS OF THE TRACTOR

- 1.3.1. The tractor should be run in, in accordance with the requirements under Subsection 6.5.
The tractor should be completely outfitted and in good working order.
- 1.3.2. DO NOT allow dismantling of design-stipulated protective enclosures and/or safeguards from the tractor, as well as other parts and/or assembly units which af-

fect its safe operation (protective grille of the fan, rear PTO enclosure, etc.)

- 1.3.3. The technical condition of the braking system, steering controls and running gear should conform to safety requirements of relevant standards and the present Manual.
- 1.3.4. The trailed agricultural machines and harvest trailers shall be fitted with a rigid towing coupler which excludes swaying and/or colliding thereof with the tractor during the transportation.
- 1.3.5. The tractor controls shall be provided with reliable locking in their operative positions.
- 1.3.6. Keep all the warning decals on the tractor clean and readable. If damaged or lost, replace them with new ones.
- 1.3.7. No leaks of electrolyte, water, fuel and/or oil shall be allowed.
- 1.3.8. Make proper use of summer- and winter-grade fuels. Refill the fuel tank at the close of each working day to reduce the moisture condensation at night.

1.4. SAFETY REQUIREMENTS FOR OPERATION OF THE TRACTOR

IMPORTANT! NEVER start up the diesel- engine from outside the cab, away from the operator's work station. When starting the engine and manipulating with the controls, always be in the cab and sitting in the driver's seat.

- 1.4.1. Prior to starting the engine, check to see if the parking brake is engaged, the power take-off (PTO) lever is in the "Brake" position, the range changeover and GB shifting levers – in the "Neutral". The lever switch of the GB pump drive should be in the "Drive from the engine" position.
- 1.4.2. Prior to getting the tractor moving, make sure that the reserve parking brake is disengaged, give an audible signal to warn bystanders and persons working on the trailed machines, then start moving smoothly. When on hauling sessions, be sure to use seat belts (to be supplied on request).
- 1.4.3. DO NOT leave a moving tractor. Prior to leaving the cab, disengage the PTO shaft, stop the engine, apply the parking brake and take out the starter key.
- 1.4.4. DO NOT operate the tractor in closed spaces without adequate ventilation. Breathing the exhaust gases can cause the lethal outcome!
- 1.4.5. Should the engine or the steering controls fail during the work, stop the tractor immediately. Remember that when the engine is shut down, a considerable greater effort should be applied to the steering wheel to drive the tractor.
- DO NOT work or walk under raised agricultural attachments. DO NOT leave the tractor for a long period of time with the mounted implement in raised position.
- 1.4.6. If the tractor front part lifts off the ground when heavy machines/ implements are mounted on the rear hitch linkage, attach ballast weights to the tractor front bar.
- 1.4.7. No passenger can be admitted to the cab during work. (However, a passenger can only be admitted when an additional seat is installed).
- 1.4.8. DO NOT operate the tractor with faulty instrumentation.
- 1.4.9. DO NOT admit smoking exhaust of the engine or substantial drop in rpm. due to overload.
- 1.4.10. In case of emergency and/or excessive increase in engine crankshaft rpm, cut off the fuel feed immediately and pull the engine emergency stop knob towards yourself.
- 1.4.11. The independent drive of the rear PTO shall be only engaged on an out-of-operation engine; while the synchronous drive – when the transmission clutch is disengaged.
- 1.4.12. When operating the tractor without using the rear PTO, set the PTO drive lever and the PTO control lever in the neutral and "Brake" position, respectively.
- 1.4.13. When engaging and disengaging the PTO, move the PTO lever smoothly to avoid damage to the shafts, gears and/or PTO tail-piece.
- 1.4.14. On detaching the PTO-driven machines from the tractor, remove the universal-joint drive

- and cover the PTO tail-piece with a protective hood.
- 1.4.15. NEVER lower the farm machine by setting the distributor lever to the "Forced Drop" position.
 - 1.4.16. Prior to starting the engine, set the gear shifter and the range changeover lever to the neutral position. When starting the engine there shall be nobody in front of the tractor, under and behind it as well as between the tractor and the machine attached to it.
 - 1.4.17. When hitching or attaching the agricultural machines or implements to the tractor, the trailer hand shall be at a safe distance until the complete stop of the tractor. The hitching or attaching operation should be only started on the operator's signal.
 - 1.4.18. Should any malfunction or fault occur, stop immediately the tractor and eliminate the cause.
 - 1.4.19. When working with the agricultural machines attached to the tractor, follow additionally the safety precautions specified for operating these machines.
 - 1.4.20. Prior to attachment of agricultural machines to the tractor, make sure that automatic catches of the RHL lower and top links are clean and serviceable. DO NOT work with catch inner recesses damaged, clogged up with dirt and/or foreign particles.
 - 1.4.21. Prior to lifting or lowering an agricultural implement as well as when making turns, make sure that there is no risk of hitting anybody or running over an obstacle.
 - 1.4.22. When on transport trips and undergoing turns with raised machine/implement, preliminary set the PTO control lever to the "Brake" position, to avoid breakdown to the tractor and/or agricultural machines/implements.
 - 1.4.23. Lower the mounted machine to its working position or lift it to attain position for transport only when the tractor is moving forward in a straight line.
 - 1.4.24. The universal-joint shaft transmitting the rotational motion from the tractor PTO to the aggregated agricultural unit tools shall be enclosed.
 - 1.4.25. Make sure that any additional equipment and/or auxiliary devices are properly installed and intended and approved for use on your tractor.
Keep in mind that your tractor, if carelessly or improperly operated and/or poorly maintained, can be a serious hazard to the operator and others. DO NOT use equipment which is not designated or authorized for installation on the tractor.
 - 1.4.26. When machine-and-tractor aggregates are running in a column, the clearance between them must be at least 30 m.
 - 1.4.27. When driving on a slippery road with the ADL engaged, run the tractor ganged up with implements at a speed not exceeding 12 km/h.
 - 1.4.28. When driving on slopes, increase the tractor wheel track to maximum possible.
 - 1.4.29. Avoid sharp turns when driving under full load and/or at a high speed.
 - 1.4.30. Operate the tractor in the twilight or at night provided the lightning equipment is serviceable and switched on.

- 1.4.31. Any cleaning, lubricating and repair works should be only performed with the engine shut down and PTO disengaged.
- 1.4.32. When operating the stationary PTO-driven equipment, brake the PTO tail-piece and stop the engine before leaving the cab.
- 1.4.33. When working with the PTO or in close vicinity to rotating components, DO NOT wear loose clothing.
- 1.4.34. When operating with stationary PTO-driven machinery, always engage the parking brake and chock both sides of the rear wheels. Make sure that the machine is reliably secured.
- 1.4.35. Check to see that the PTO shaft tail-piece is safely enclosed and, if the PTO is not used, refit the PTO tail-piece hood in place.
- 1.4.36. Use the synchronous PTO mechanism at low (up to 15 km/h) tractor speeds only. Failure to do so could cause severe damages in the PTO drive.
- 1.4.37. The tractor operation on slopes is only permitted in daytime, at a speed not exceeding 10 km/h and the wheeltrack at least 1800 mm provided the steepness does not exceed 9°.
- 1.4.38. When the machine-and-tractor aggregates are working or passing in the vicinity of electric power lines (EPL), the distance from the top aggregate point to the lines should not exceed:

Line voltage, up to, kV	11	20-25	110	154-220	330-500
Distance horizontal, m	1.5	2	4	6	9
Distance vertical, m	1	2	3	4	6

- 1.4.39. DO NOT work with attached heavy machines unless the front ballast weights are installed.
- 1.4.40. Trailed and semi-trailed agricultural machines should be additionally connected to the tractor with using safety chains.

1.5. SAFETY REQUIREMENTS FOR TRANSPORT SESSIONS AND TRACTOR TOWING

- 1.5.1. When performing the transport works, observe the road regulations adopted in the territory of the country.
- 1.5.2. The transport works may be performed by the operators with the tractor driving experience of not less than two years who have passed an examination in the road regulations.
- 1.5.3. When using the tractor for performing the transport works:
 - increase the tractor wheel track to at least 1800 mm;
 - check the serviceability of the brakes;
 - interlock the brake pedals, check and, if necessary, adjust the brakes for simultaneous operation;
 - check operation of the parking brake;
 - check the condition of lighting and audible signalling systems;
 - the transport trailers should be fitted with rigid couplers and, besides, connected to the tractor with using a safety chain or cable;
 - under no circumstances should the tractor be run downhill with gear disengaged (by coasting); apply the same gear both down and uphill;
 - if the trailer weight exceeds that of the total actual weight of the tractor, it is mandatory that it should be equipped with independent brakes. The faster you move and the great-

- er the trailed mass, the longer is the safe stopping distance.
- 1.5.4. **DO NOT** stop the tractor on slopes. If it is necessary to stop, put the tractor into 1st gear and apply the parking brake.
 - 1.5.5. Before operating the tractor, turn on the compressor, check the condition of the brake pneumatic drive, air pressure in the pneumatic system. Remove the faults detected.
 - 1.5.6. The trailers to be combined with the tractor should have a braking system which is able to ensure:
 - a) braking the trailer on the run;
 - b) applying the brake in case of disconnection of the trailer from the tractor;
 - c) keeping the trailer when parked on a slope;
 - d) preventing the trailer from pushing actions against the tractor in cases of abrupt changes in speed.

The trailer should be connected to the tractor with using a safety chain.
 - 1.5.7. Carrying people in trailers is prohibited.
 - 1.5.8. To avoid tip-over, take care when running the tractor. Set speeds safe with respect to the actual condition of the road surface; especially so, when driving on a rugged terrain, crossing ditches, taking a grade and/or making sharp turns.
 - 1.5.9. The road speed at turns should not exceed 5 km/h, on a slippery road – 3 km/h. Ride downhill in first or second gear. Speeds on approach paths and passages should not exceed 10 km/h.
 - 1.5.10. When loading/unloading the trailer, brake the tractor by applying the reserve parking brake.
 - 1.5.11. With the HSCU unit out of operation, the tractor can be towed, but at a speed of up to 10 km/h, max., and at a distance not exceeding 5 km.
 - 1.5.12. Tractors in combination with a trailer used on public roads should be run with the “Tractor&Trailer Rig” warning sign illuminated, in full conformance with the Road Regulations.
- ## 1.6. SAFETY REQUIREMENTS FOR MAINTENANCE
- 1.6.1. All the maintenance operations shall be carried on a tractor placed on a level ground, with the engine shut down, the parking brake applied and the PTO tail-piece braked.
 - 1.6.2. To lift the tractor, use a jack; after lifting, put blocks and props under the frond axle bar, rear wheels axle shafts or location parts of the tractor framework.
 - 1.6.3. When using hoisting and transport equipment, observe relevant safety precautions.
 - 1.6.4. To avoid accidental splash-out of fuel when refuelling the tractor using mechanized equipment, remove the wire gauze filter from the fuel tank throat. This filter is to be used for refuelling the tractor by hand, under field conditions, only.
 - 1.6.5. When examining and/or adjusting the parts to be controlled, make use of a 36 V (max.) inspection portable lamp. The lamp should be protected with wire screen.
 - 1.6.6. Tools and appliances to be used in the course of maintenance should be in good working order, suitable for their purpose, and ensure safe performance of the works.

- 1.6.7. NEVER inflate the tyres without monitoring the pressure.
- 1.6.8. When servicing the storage batteries:
- keep the skin from contact with electrolyte;
 - to clean the storage batteries, use rags soaked in ammonia solution (ammonium hydroxide);
 - to top up the electrolyte level in the battery, use only distilled water;
 - DO NOT check the state of charge of the storage battery by short-circuiting the terminals;
 - DO NOT connect the storage battery in wrong polarity.
- 1.6.9. To keep the electronic units from damage, follow the precautions as given below:
- do not disconnect the storage battery (SB) terminals while the engine is running, since it results in peak voltage in the charging circuit and unavoidable damage of diodes and transistors;
 - do not disconnect the electrical circuit wires until the engine completely stops and all the electrical switches are in the OFF position;
 - take care not to cause short-circuiting due to incorrect connection of wires. Short-circuits or wrong polarity causes damage to diodes and transistors;
 - DO NOT connect the SB to the system of electrical equipment until terminals and voltage are checked for proper polarity;
 - DO NOT check the availability of electrical current by "sparking", since this causes immediate breakdown of transistors;
 - NEVER set the battery disconnect switch to the OFF position while the engine is running;
- DO NOT operate the tractor without a storage battery.
- 1.6.10. The cooling system operates under pressure maintained by a valve installed in the filler cap. It is dangerous to remove the cap on a hot engine. To avoid burns on your face and hands, take special care when opening the radiator filler cap on a hot engine; cover the cap with thick fabric and put on a glove.
- 1.6.11. To avoid burns, take special care when draining coolant or water from the cooling system, or hot oil from the engine, hydraulic system and transmission.
- 1.6.12. To exclude the explosion risk, there shall be no sources of naked flame in close proximity to the engine fuel system and/or storage batteries.
- 1.6.13. To install and dismount the engine, use a steel cable fastened to the eye-bolts provided for the purpose on the engine.
- 1.6.14. Any repair works requiring the electric welding to be done on the tractor shall be performed with the battery disconnect switch turned OFF.
- 1.6.15. DO NOT make any modifications to the design or structure of the tractor or its components, if not agreed with the Manufacturer. Otherwise, the tractor will be devoid of the guarantee privilege.
- 1.6.16. To exclude any possibility of getting severe injuries, all the adjustment operations should be carried out with the tractor placed on a flat level ground, with the engine shut down. Also, the tractor should be safely stopped from moving by means of chocks placed under the rear wheels on the front and at the rear.

1.7. FIRE PREVENTION REQUIREMENTS

- 1.7.1. The tractor should be provided with fire-fighting equipment such as a spade and fire extinguisher. NEVER operate the tractor without fire-fighting equipment.
- 1.7.2. NEVER refill the tractor with the engine running.
- 1.7.3. DO NOT smoke when refilling the tractor.
- 1.7.4. DO NOT fill the fuel tanks completely. Leave some space for fuel expansion.
- 1.7.5. NEVER add gasoline and/or other mixtures to diesel fuel. Such combinations may be a cause of enhanced danger of inflammation and/or explosion.
- 1.7.6. The tractor parking lots, as well as fuel and lubricant depots should be ploughed around to make a strip 3 m wide, and equipped with fire-fighting equipment.
- 1.7.7. Refill the tractor with fuels and lubricants using mechanized means, with engine fully stopped. At night, use a light-up facility. DO NOT refuel the tractor by means of a bucket.
- 1.7.8. When performing the repair works involving electric arc or gas welding under field conditions, clean the parts and assembly units from vegetable leftovers.
- 1.7.9. Keep the manifold and muffler stack clean from dust, fuel and straw residue, etc.
- 1.7.10. DO NOT allow straw to be taken up by rotating parts of the machines ganged up with the tractor.
- 1.7.11. When washing/cleansing the parts and/or assembly units with kerosene or petrol, take adequate measures to exclude the

possible inflammation of the flushing fluid vapours.

- 1.7.12. NEVER operate the tractor in fire-hazardous locations, with its bonnet and other protective devices removed from hot parts of the engine.
- 1.7.13. NEVER use naked flame to heat oil in the engine oil sump, as well as when refuelling the fuel tanks or burning out the soiled core of the radiator.
- 1.7.14. Whenever a seat of fire is detected, bury the fire with sand, cover it with tarpaulin, sacking or any other dense, thick material. Use a carbon dioxide fire extinguisher for the purpose. NEVER attempt to put out burning fuel with water.
- 1.7.15. Keep an eye that easy inflammable materials are well away from the exhaust manifold and the muffler.
- 1.7.16. When harvesting hay and straw or working in places with higher fire-hazard, make use of spark quenchers in the exhaust system, in conjunction with a muffler, or as separate facilities.

1.8. SAFETY REQUIREMENTS TO BE OBSERVED DURING PRESERVATION

- 1.8.1. When putting the tractors for storage, performing the maintenance during the storage and return from the storage to operation, observe the relevant instruction of this Section, as well as safety requirements as per State Standard (ГОСТ) 9.014-78.
- 1.8.2. When stored, the tractor should be placed on special supports, or trestle, precluding its capsizing or spontaneous displacement.

1.9. HYGIENE REQUIREMENTS

- 1.9.2. The first-aid kit should be completed with bandages, a bottle of tincture of iodine, liquid ammonia, borated petrolatum, a jar of household soda, menthol valerate, and dipyrone.
- 1.9.3. Make use of natural ventilation of the cab or the air heating/cooling unit, as required by operating conditions.
- 1.9.4. Fill the thermos with fresh, clean drinking water every day.
- 1.9.5. If the period of continuous operation of the tractor exceeds 2.5 hours within the working shift, it is necessary to use individual protective means as per State Standard (ГОСТ) 12.4.051-87 to muffle the noise (such as ear muffs, antiphones).

BRIEF DESCRIPTION

The BELARUS 1523/1523.3 agricultural power-intensive wheeled tractor of the 3.0 tf traction class with the 4x4 wheel-drive arrangement is intended for performing various jobs with attached mounted, semi-mounted, trailed machinery and implements, load handling facilities, harvesting complexes, and in running stationary agricultural machines off the PTO shaft, as well as in road transport missions in various climatic zones.

The tractor is equipped with a six-cylinder, turbocharged in-line engine. The power-train mechanisms: transmission clutch, speed gearbox, rear axle with a differential lock-up feature, rear power take-off shaft with double-reduction (540 and 1000 rpm) independent and synchronous (3.3 and 6.2 revolutions per meter of travel) are located immediately after the engine.

Clutch: dry double-disk, closed-type, with a hydrostatic control drive.

Gearbox: synchromesh, fixed-ratio, range-type; assures 16 forward speeds and 8 reverse speeds *.

Running Gear: rear driving wheels, front driving and steerable wheels. Front wheel tyre dimensions 420/70R24, rear-wheel tyres – 520/70R38.

Front Driving Axle: portal-type, with detachable half-axle housings and spur planetary reduction gearings of the final drive.

The Steering control of the tractor is a hydrostatic steering unit consisting of a gear feeding pump, gerotor-type metering pump and two differential hydraulic

cylinders that ensures simple and easy control of the tractor when performing various works. The steering control ensures the turn of the steerable wheels and reduces the force to be applied to the steering wheel in case of change of the tractor motion direction.

To improve the traction performance and steerability of the tractor, additional counterweights can be installed on the fore bar.

The RHL Control Hydraulic System with the BOSCH integral block, made up of a slide-valve distributor to control external hydraulic cylinders and electromagnetically controlled regulator ensures the operation of the tractor coupled with agricultural machinery and implements using the draft, position or combined control of tool position relative to the tractor framework, as well as power take-off to drive tools of the agricultural machines.

The tractor is equipped with a pneumatic system for operating the hydraulically-actuated trailer brakes, and single-line and dual-line brake system.

The Tractor Brakes are multiplate ones with hydrostatic actuator/ They are located on driving pinions of the hub drives.

* 24 forward speeds and 12 reverse speeds optionally.

The tractor cab is a cylindrical structure with a rigid protective framework, thermo-, noise- and vibration-isolated featured by the improved interior design, convex (panoramic) tinted injury-safe glasses, a sun-protective blind, more comfortable location of handles on the side control desk, an additional folding-back seat and additional rear window. The cab is fitted with rear-view mirrors, electrical windscreen and rear-screen wipers. A frameless door and glued windscreens assure clear visibility. The natural ventilation is achieved through the side and/or rear windows. The two fuel tanks with the total capacity of 250 l are located beneath the cab floor and on the right-hand side of the tractor. The engine is covered with a tilt-forward bonnet, with removable side panels.

When open, the engine cover is fixed with a stay. On the customer's order, the tractor can be equipped with extra options (a RHL cross-bar, additional seat, auxiliary spacer-ring member for installing twinned wheels, PTO-driven front hitch mechanism, etc.)

The BELARUS-1523B/1523B.3 tractors are equipped with a reversible control station, designed for a long-term operation in the reversal, with agricultural machines attached to the rear hitch linkage.

The BELARUS-1523.3 tractors is a further modified version of the basic model BELARUS-1523 equipped with a Д-260-1S2 engine certified to the 2nd stage of Directive 2000/25EC.

Serial Numbers of Tractor Components

A nameplate with the tractor and engine Serial Nos. is fastened in the right-hand at the rear of the cab. Beneath the nameplate, there is a plate indicating the Serial number of the cab.



Минский тракторный завод	Minsk Tractor Works
БЕЛАРУС	BELARUS
№ трактора	Tractor No.
Масса	Weight
№ двигателя	Engine No.
Год выпуска	Year of production
ЗРОБЛЕНА У БЕЛАРУСІ	MADE IN BELARUS

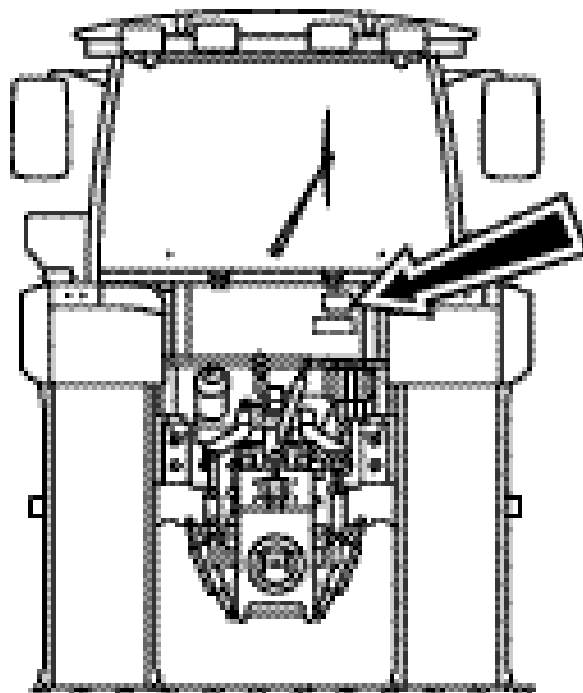

The Serial Number of the tractor is duplicated on the semi-frame right-hand side member and on the right-hand plate of the front counterweights.

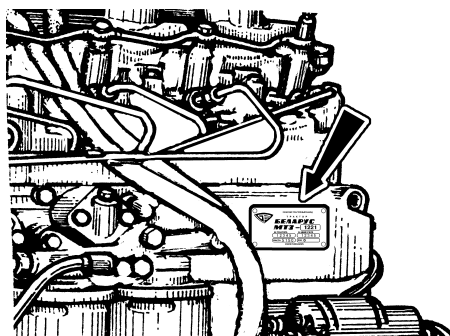

The Serial Number of the engine is duplicated on the manufacturer's nameplate attached to the cylinder block, on the left-hand side.

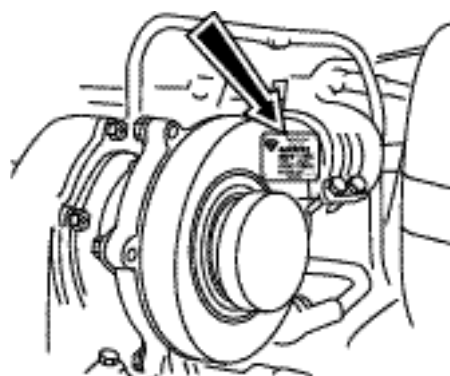

Минский моторный завод	Minsk Engine Works
ДИЗЕЛЬ	DIESEL ENGINE
заводской №	Serial No.

Serial number of the engine turbocharger

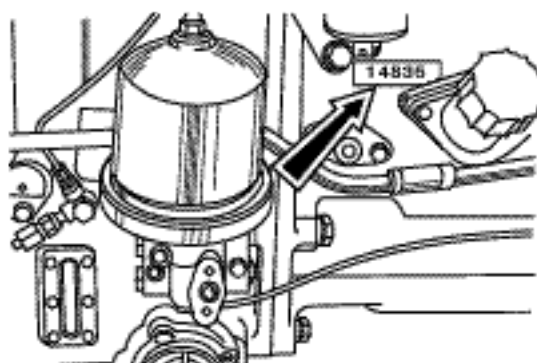

Serial number of the clutch

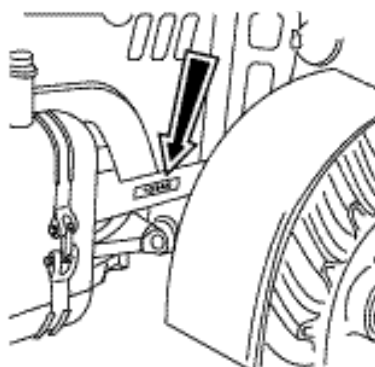

* Or Д-260.1S2.

The Serial Number of the transmission is stamped on a plaque of the rear axle housing, on the right-hand side.

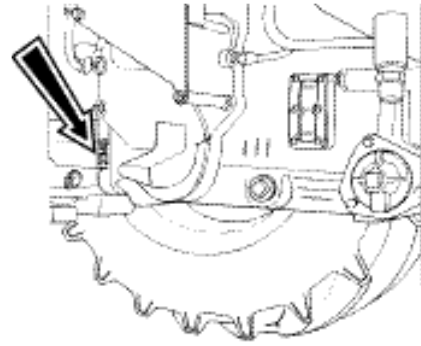

The Serial Number and version of the FDA with detachable axle-shaft housings are stamped on the right-hand housing, at the front of the FDA.

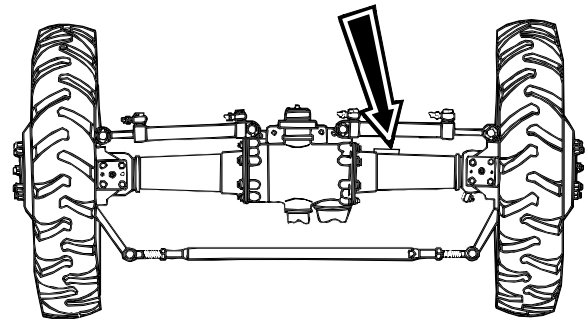

TECHNICAL DATA

Description	Unit of measurement	Value			
GENERAL DATA					
Tractor type	–	Universal, row-crop			
Tractor make	–	BELARUS			
Tractor model	–	1523/1523B/1523.3/1523B.3			
Calculated speed of movement on the 520/70R38 tyres at the rated engine crankshaft rotational speed:					
Forward running in:		(16F+8R)		(24F+12R)	
			Range		Range
1st gear	km/h	1.74	I	1.7	I
2nd gear		2.44	I	2.3	I
3rd gear		3.35	I	2.9	I
4th gear		4.58	I	3.8	I
5th gear		3.77	II	4.9	I
6th gear		5.29	II	6.3	I
7th gear		7.26	II	3.3	II
8th gear		9.94	II	4.4	II
9th gear		5.70	III	5.7	II
10th gear		7.99	III	7.3	II
11th gear		10.97	III	9.4	II
12th gear		15.01	III	12.2	II
13th gear		12.37	IV	5.1	III
14th gear		17.34	IV	6.7	III
15th gear		23.80	IV	8.8	III
16th gear		32.58	IV	11.3	III
17th gear				14.5	III
18th gear				18.8	III
19th gear				9.8	IV
20th gear				13.0	IV
21st gear				16.9	IV
22nd gear				21.8	IV
23rd gear				28.0	IV
24th gear				36.3	IV
Reversing in:					
1st gear		2.73	I	2.5	I
2nd gear		3.83	I	3.2	I
3rd gear		5.26	I	4.1	I
4th gear		7.20	I	5.3	I
5th gear		5.93	II	6.8	I
6th gear		8.31	II	8.9	I
7th gear		11.41	II	4.6	II
8th gear		15.61	II	6.1	II
9th gear				8.0	II
10th gear				10.3	II
11th gear				13.2	II
12th gear				17.1	II

Description	Unit of measurement	Value
Rated tractive force	kN (kgf)	30 (3000)
Overall dimensions (design):		
length, including the rear hitch linkage in transport position	mm	4710±50
width, over outer ends of rare wheel axle-shafts	mm	2250±50
height, to top of cab, max.	mm	3000±50
Base of the tractor	mm	2850±30
Wheel track of the tractor		
over the front wheels	mm	1540 – 2090
over the rear wheels	mm	1600 – 2440
Angle of transversal static stability, min.	degrees	35
Ground clearance:		
under FDA (at axle centre)	mm	440
under rear axle (lower links brackets to ground)	mm	455+5
under HLL cylinder bracket	mm	388
Least turning radius based on the middle of the trace of the outer front wheel with the wheel track of 1800 mm and the inner rear wheel slightly braked	m	5.0
Tractor weight (as shipped ex-Works)	kg	5800±100
Fording	m	0.85
Maximum permissible weight of towed trailer on a 12° max. downgrade	t	15
ENGINE		
Model	–	Д-260.1/Д-260.1S2
Type	–	Four-stroke, in-line, turbocharged *
Number of cylinders	pcs	6
Firing sequence	–	1-5-3-6-2-4
Cylinder diameter	mm	110
Piston stroke	mm	125
Displacement volume	l (cm ³)	7.12 (7120)
Compression ratio	–	15.0
Cooling system	–	Liquid, with coolant forced circulation from the centrifugal pump
Lubrication system	–	Combination type
Oil cooling system	–	Oil-to-fluid heat exchanger built into the engine
Regulation of thermal regime	–	Automatic, by means of two thermostats
Engine rated power	(kW)	114.0/116.0
Engine operating power	(kW)	109.0 ^{+5.2} /111.0±2.0
Crankshaft rated rotational speed	rpm	2100
Crankshaft idling rotational speed at, max.	rpm	2275
Minimum stable idling speed, no more than	rpm	800
Crankshaft rotational speed at maximum torque	rpm	1400
Maximum torque value	N•m (kgf•m)	596.8/647.0

* With intermediate cooling of the supercharged air for the Д-260.1S2 engine

Description	Unit of measurement	Value
Correction coefficient of reserve torque, at least, %)		15.0/25.0
High-pressure fuel pump	–	PP6M10P1f-3492 MOTORPAL (Czechia) or 363-40.01 YAZDA (Russia)
Fuel injection advance angle to TDC	deg.	20±1 (YAZDA); 22±1 (MOTORPAL) – Д-260.1; 15±1 (YAZDA); 16±1 (MOTORPAL) – Д-260.1C; 6±1 – Д-260.1C2
type	–	6 slide-valve type, in-line
camshaft rotation direction	–	Clockwise
Type of the boost pump	–	Displacement type, with eccentric drive
Type of the hand-driven boost pump	–	Displacement type
Rotational speed governor	–	All-speed, with automatic start fuel enrichment and pneumatic adjuster
Injector	–	ФДМ-22 / 455-1112010-50
Fuel injection pressure	MPa (kgf/cm ²)	21.6 ^{+0.8} / 23.5 ^{+1.2} (220 ⁺⁸) / (240 ⁺¹²)
Air cleaner	–	Three-stage
Starting system	–	Electric starting, with start-up aiding means
Dry engine weight	kg	650+3%
Turbocharger make	–	TKP7 BZA Open Joint-Stock Company (Belarus) or K-27-16-02/K27-61-08 Turbo (Czechia)
Relative oil consumption, in % to the fuel consumption within the guaranteed service life, not more than	%	1.1
Relative oil consumption for waste after 60 hours of the tractor operation, in % to the fuel consumption, not more than	%	0.4
POWER TRANSMISSION		
Clutch	–	Friction, dry-plate type, constantly closed, two-disk
Clutch control drive	–	Hydrostatic
Gearbox 16F+8R or 24F+12R	–	Multi-speed, constant-mesh gear, four-speed (КП 16F+8R) or six-speed (КП 24F+12R) shifting in each of 4 ranges of forward motion and 2 ranges of reversing by means of synchronizers
Rear axle	–	With main drive – a circle-arc bevel pinions pair, differential with locking and hub drives – cylindrical gear pairs and a planetary final drives
Front driving axle	–	Portal-type, with detachable half-axle housings or unit-cast bar, with final drive spur planetary reduction gearings. Main drive: circle-arc bevel pinions pair.
FDA drive	–	From the GB through an electrically- and hydraulically controlled friction-type clutch and a universal-joint shaft
FDA control	–	An electrohydraulic distributor provides the automatic control and forced engagement of the drive.
Brake control drive	–	Hydrostatic, selective
Brakes	–	8-disk brakes operating in an oil bath and

Description	Unit of measurement	Value
		acting on the rear wheels and, through the FDA drive, the front wheels. The control is interlocked with the trailer's brakes.
Auxiliary parking brake	–	Wet-friction type, combined with the service brakes, with a separate mechanical drive. The control is interlocked with the trailer's brake pneumatic drive
Trailer's brake control drive	–	Pneumatic dual-line interlocked with the tractor brake controls
Pneumatic system pressure limited by a safety valve	MPa (kgf/cm ²)	0.85...1.0 (8.5...10)
Regulator maintained pressure	MPa (kgf/cm ²)	0.65...0.80 (6.5...8.0)
REAR PRO SHAFT		
Drive	–	Two-speed, independent, synchronous
Tail-piece rotational speed:		
independent drive	rpm	540 (PTO 1c and 1) at the engine rotational speed of 1924 rpm for transmitting the power of not more than 60 kW; and 1000 (PTO 3 and 2) at the engine rotational speed of 1910 rpm for transmitting the full power
synchronous drive	rev. per m of travel	3.8 and 6.2
Tail-piece dimensions and hand of rotation	–	PTO3 (20 splines); PTO1c (8 splines – on the SPTA kit); PTO2* (21 splines); PTO1* (6 splines). Clockwise
FRAMEWORK, RUNNING GEAR		
Tractor framework	–	Semi-frame
Framework suspension	–	Rigid
Running gear	–	Rear and front wheels are driving wheel, with pneumatic tyres. The front wheels are steering wheels. Twinning of rear tyres is made possible with the help of an auxiliary spacer-ring member.
Tyres (standard):		
front wheel		420/70R24
rear wheel		520/70R38
STEERING CONTROL		
Type	–	Hydrostatic
Type of the feed pump	–	Gear-type
Displacement volume	cm ³ /rev.	14 – 16
Rated pressure	MPa (kgf/cm ²)	16 (160)
Direction of rotation	–	Left
Type of the metering pump	–	Gerotor-type
Displacement volume	cm ³ /rev.	160
Safety valve adjustment pressure	MPa (kgf/cm ²)	14.0 (140) (Two hydraulic cylinders)
Pressure of anti-hammering valves	MPa (kgf/cm ²)	22.5 (225)
Type of the turn mechanism	–	Two differential hydraulic cylinders

* Optionally.

Description	Unit of measurement	Value
		Ø50x200 mm
HYDRAULIC SYSTEM		
Type of the hydraulic system	–	Separate-modular, with BOSCH hydraulic units providing the possibility of the draft, position and combination control of agricultural machinery and dampening of farm implement oscillations when in the transport position.
Pump	–	Gear-type, clockwise
Model	–	НШ32-3, УКФ-3, Д-3
Drive	–	From the engine, through an independent PTO drive pinion.
Pump capacity, max.	l/min	55
Safety valve adjustment pressure	MPa (kgf/cm ²)	20 ^{-2,0} (200 ⁻²⁰)
Hitch linkage cylinders (2 pieces)	mm	Л90x250
Integral BOSCH unit* comprising:	–	3-section, 4-position flow-through type distributor manufactured by the BOSCH Company and EHR-23LS electrohydraulic slide-valve regulator
Supply voltage of the regulator electromagnets	V	12
REAR HITCH LINKAGE		
Hitch linkage mechanism	–	Articulated four-link chain, Category 3
Lifting capacity with the centre of gravity of the load at the distance of 610 mm from the suspension axis	kN (kgf)	46 (4600)
HAUL-AND-DRAW COUPLER		
Type	-	Universal; including a towing gear (hitch clevis) and a "Python" coupling device (optionally), as well as coupling mechanism (drawbar)
Towing mechanism (TCY-3B)	-	Lift-type, height-adjustable
PTO end-face-to coupling point distance in horizontal plane	mm	325
Ground surface-to-horizontal axis of the hitch clevis	mm	425...885 (at 65 mm intervals)
CAB		
Cab	–	Refer to Section "Brief Description"
Reversible control post:		
steering column	–	Optional, with the metering pump similar to that of the first column
fuel feed control	–	Doubled, cable-type
speed clutch and brakes controls	–	Doubled pedal control of the clutch and brakes
seat	–	Main seat rotated through 180° by a reversal mechanism
ELECTRIC EQUIPMENT AND INSTRUMENTATION		
Rated voltage of		
on-board circuit	V	12

* Prior to installing the integral BOSCH unit, tractors can be fitted with autonomous BOSCH distributors or an ERH4 BOSCH regulator.

Description	Unit of measurement	Value
starting system	B	24
Supply circuit	–	12V storage batteries (2 pieces) each 120 Ah connected in parallel; starting discharge current 880 A at -18°C; a 14 V, 1150 W alternator (for the Д-260.1 engine) or 2000 W (for the Д-260.1S2 engine) with a built in rectifier and voltage regulator; glow plugs
Illumination and light signalling systems	–	<ul style="list-style-type: none"> – Headlights to lighten the road, with high and low beams (2 off); – Floodlights, rare (4 off) and front (4 off); front lights (2 off) including the marker lights and tractor turn signals; – Tail lights (2 off) incorporating the marker lights, tractor turn signals and brake signal; cat's eyes; – Number plate light; – "Tractor & Trailer" sign light; – Cab interior light; – Light signalling system.
Audible signalling system	–	A set of two horn tone signals
Audible emergency signalling system	–	A buzzer (in case of oil drop in the engine, air pressure in the pneumatic system or excessive increase of coolant temperature, beyond the permissible limit).
Agricultural trailer-type machinery loads connection	–	By means of a combination-type nine-pin socket.
Instruments (combined instrument cluster) and warning light in-line block		<ul style="list-style-type: none"> – Voltage indicator, with the additional SB charge signalling; – Fuel level indicator, with fuel reserve level signalling; – Temperature indicator, with signalling of coolant critical temperature; – Engine oil pressure indicator, with alarm of low oil level in the engine; – Pneumatic system air pressure gauge, with alarm of low pressure in the system; – Oil pressure indicator for the transmission hydraulic system.
Combined indicator		– Electrical (complete with the programming panel);
Warning lights		– Signalling of high beam, tractor and trailer turns; parking brake engagement; air filter clogging; oil pressure in HSCU; differential lock-up and FDA engagement; brake fluid level in the master cylinders
BALLAST WEIGHTS		
Mass of one ballast weight	kg	45+1.5
Total weight	kg	510+20
OPTIONAL ATTACHMENTS (to be delivered on a separate order)		

Description	Unit of measurement	Value
Front hitch mechanism (HM)	–	HY-2
Load capacity at the ends of lower longitudinal rods	kg	2500
Self-coupler of the front HM	–	CA-1
Rear hitch cross-bar		
PTO end-face-to-coupling point distance	mm	675
distance of rearrangement of the coupling point in the vertical plane	mm	200 – 980 (stepless)
distance of rearrangement of the coupling point in the horizontal plane	mm	400 (to both sides, with the step of 8 mm)
diameter of the connecting opening	mm	32
vertical static load	kgf	600
Towing mechanism (drawbar)		
PTO end-face-to-coupling point distance in the horizontal plane	mm	400; 500
ground-to-coupling point distance	mm	500
permissible vertical load:		
on 400-mm arm off the PTO end-face	kgf	2000
on 500-mm arm off the PTO end-face	kgf	1500
Auxiliary spacer-ring member for fitting twinned rear wheels	pcs	2
Additional seat	–	For a passenger
Front PTO		
drive	–	Independent, single-speed
PTO tail-piece rotational speed at 1845 rpm of the engine crankshaft	rpm	1000
tail-piece rotation direction	–	Clockwise (as seen from the tail-piece end-face).
tail piece	–	PTO2, 21 splines
transmitted power, not more than	h.p. (kW)	60 (44)
Haul-and-draw coupler TCY-2P "Python"	–	Non-adjustable
external diameter of the coupling spindle	mm	40
PTO end-face-to-spindle centre distance	mm	110
Permissible vertical load	kgf	3000
Ground surface-to-coupling point distance	mm	500

Description	Unit of measurement	Value
Tyres:		
front	–	420/70R24
rear	–	520/70R38
Rear PTO tail-piece	–	PTO1 (6 splines) and PTO2 (21 splines)

DRIVE CONTROLS AND INSTRUMENTATION

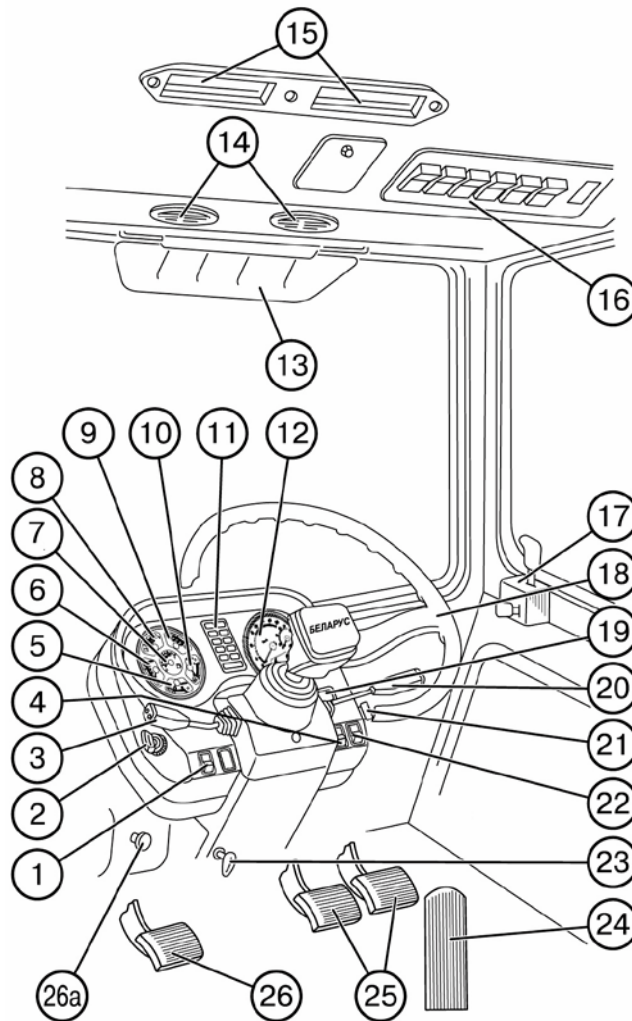

1. Battery remote disconnection switch
2. Starter and instrumentation switch
3. Multi-function control stalk (turn indicators, high-low beam, horn)
4. Front floodlights switch
5. GB oil pressure gauge
6. Pneumatic system air pressure gauge
7. Fuel-level gauge
8. Voltage indicator
9. Coolant temperature gauge
10. Engine lubrication system oil pressure gauge
11. Pilot lamp panel
12. Combined indicator
13. Sun visor
14. Air distributors

15. Air recirculation gate outlets
16. Switch in-line block (floodlights, heater fan, rear window wipers, "Road train" light)
17. Door lock
18. Steering wheel
19. Indicator control panel
20. Windscreen wiper and washer lever switch
21. Fault signalling push-button
22. Central light switch
23. Steering wheel tilt adjustment lever
24. Fuel feed control level
25. Service brake pedal
26. Clutch pedal
- 26a. Knob handle for engine stoppage emergency shutdown

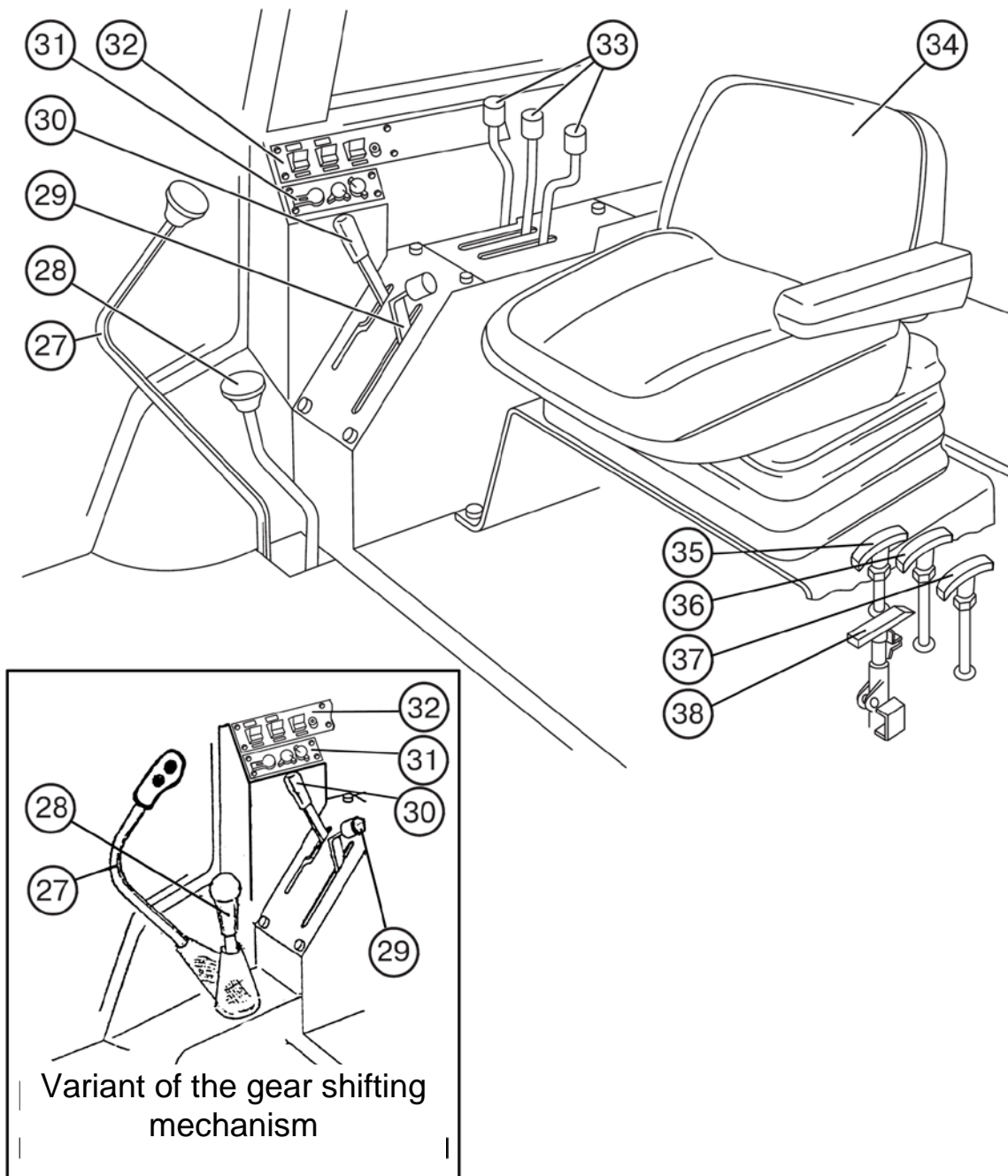

- 27. Gear-shift lever
- 28. Range selector lever
- 29. Fuel feed control lever
- 30. PTO operating lever
- 31. Hydraulic hitch linkage control unit
- 32. Control panel of the differential lock-up, FDA and FPTO (if installed)
- 33. External hydraulic cylinders control handles
- 34. Seat
- 35. PTO independent/synchronous drive changeover lever
- 36, 37. Creeper gear control lever (if installed)
- 38. Parking brake lever

Front Floodlights and Headlights Switch (1)

On pressing the key (1) the front bracket-mounted floodlights or headlights are turned ON.

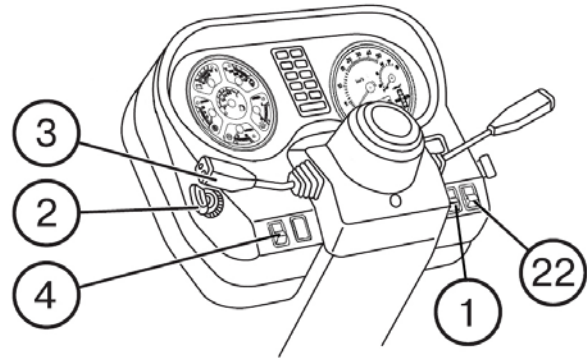

Starter and instrumentation switch (2)

The switch has four positions:

0 –OFF;

I –instruments, pilot lamp block and glow plugs are on; simultaneously, the emergency oil pressure warning lamp on the engine oil pressure indicator lights up and the horn (buzzer) sounds;

II –the starter is ON (non-fixed position); once the engine has started, the warning lamp goes out and the horn stops;

III –power supply of the radio set, tape recorder, etc. (by turning the key counter-clockwise).



Multi-Function Control Stalk (steering column-mounted) (3)

It provides for switching on the turn indicators, switchover of the headlights high/low beam, high-beam signalling and energizing the horn.

The Turn Indicators are turned ON by moving the stalk forward or backward. With the turn completed by the tractor, the stalk is reset automatically to the initial position.

The Horn is turned ON by depressing the stalk in axial direction. The signal can be turned on in any position of the stalk.



The high/low beam switching-over is achieved (after pressing preliminary the key-switch (22) to its position “3”) by shifting the handle up and down along the steering column axis: high beam – lower fixed position; low beam – middle fixed position; high beam flashing – by shifting it upwards against the stop from the middle position (non-fixed position).

Battery Disconnect Pushbutton Switch (4)

Pressing the button once connects the battery to the system, pressing it repeatedly disconnects the battery.

Instrument Cluster

The device incorporates six indicators (5, 6, 7, 8, 9, 10) together with the signal lamps (6a, 7a, 8a, 9a, 10a).

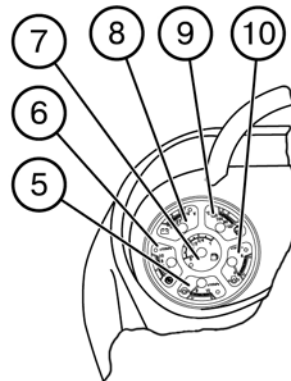

GB Oil Pressure Gauge (5)

The gauge scale has three zones:

- operating: from 800 to 1500 kPa (8...15 kgf/cm²);
- non-operating (2 off): from 400 to 800 kPa (4...8 kgf/cm²) and from 1500 to 1800 kPa (15...18 kgf/cm²).

Pneumatic System Air Pressure Gauge (6)

The gauge scale has three zones:

- operating: from 500 to 800 kPa (5...8 kgf/cm²);
- non-operating (2 off): from 0 to 500 kPa (0...5 kgf/cm²) and from 800 to 1000 kPa (8...10 kgf/cm²).

The gauge scale is provided with a red pilot lamp (6a) which lights up when the pressure in the pneumatic system drops below 500 kPa (5 kgf/cm²).

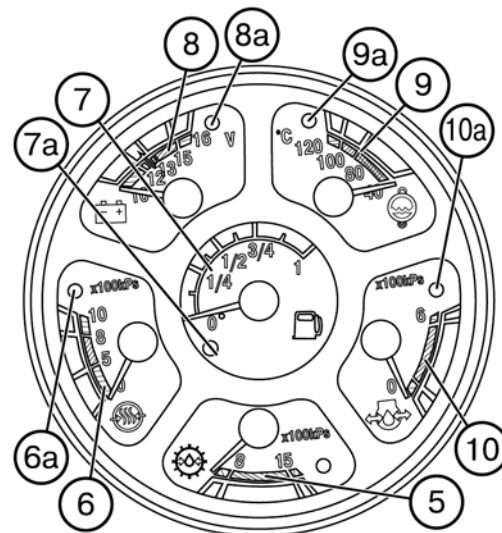

Fuel-Level Gauge (7) with an amber reserve fuel lamp (7a). The gauge scale has the following marks: “0 – 1/4 – 1/2 – 3/4 – 1”.

Voltage indicator (8)

The device indicates SB voltage on a shut down engine, when the starter key (2) is in position “I”. When the engine is running, the indicator shows the voltage at the alternator terminals. A red pilot lamp (8a) is built into the voltage indicator (8). It lights up, if no charging of an auxiliary storage battery occurs.

The voltage indicator scale has the following zones:

Table 4-1

Scale zone, code colour	State of the supply system	
	Engine stopped	Engine running
10.0-12.0 V red	Storage batteries fully discharged	Alternator inoperative
12.0-13.2 V yellow	Storage batteries charged to normal	No charge of the storage battery (low charging voltage)
13.2-15.2 V green		Normal charge mode
15.2-16.0 V red		Overcharge of the storage battery
White mark in the yellow zone	SB rated EMF – 12.7 V	

IMPORTANT! If the voltage indicator (8) shows no charging of the storage batteries, check the condition and tension of the alternator driving belt.

Engine Coolant Temperature Gauge (9) with an alarm temperature signal lamp (9a) (red colour).

The device scale has three zones:

- operating – 80...100°C;
- non-operating (2 off) – 40...80°C and 100...120°C.

Engine Lubrication System Oil Pressure Gauge (10) with a red pilot lamp of the emergency oil pressure drop (10a).

The device scale has three zones:

- operating: from 100 to 500 kPa (1...5 kgf/cm²);
- non-operating (2 off) – from 0 to 100 kPa (0...1 kgf/cm²) and from 500 to 600 kPa (5...6 kgf/cm²).

Combined indicator

The combined indicator (hereinafter referred to as the TSM) displays the information on the operating parameters of the systems and units of the tractor and provides the operator with the data on a disturbance of the operation or failure of any systems.

The TSM comprises the following indicators and signalling lamps:

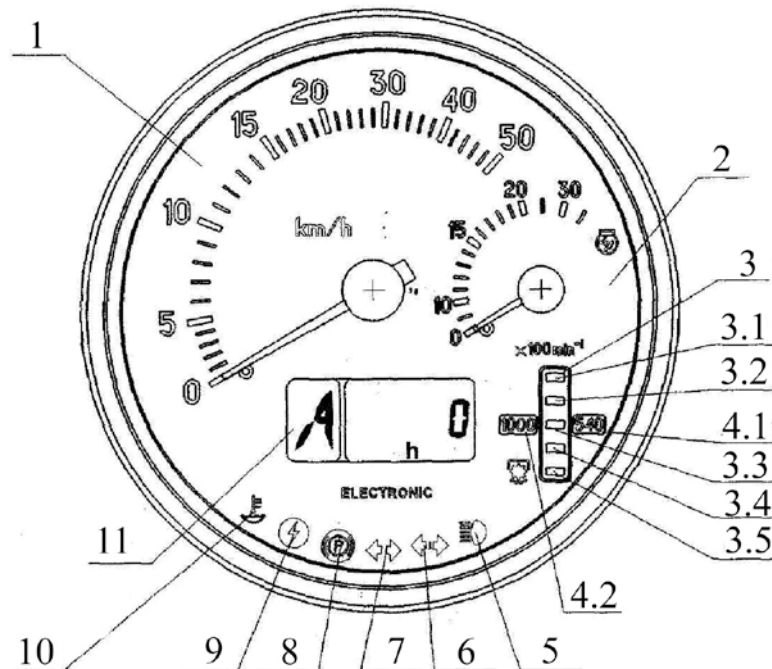

- 1 – speed gauge (pointer indicator);
- 2 – engine rotational speed gauge (pointer indicator);
- 3 – PTO rotational speed gauge (light indicator);
- 3.1, 3.5 – segments of the PTO rotational speed scale (yellow);
- 3.2, 3.3, 3.4 – segments of the PTO rotational speed scale (green);
- 4.1, 4.2 – indicators of the ranges of the PTO rotational speed scales (yellow);
- 5 – light indicator of switching on the high beam of the headlights (blue);
- 6 – light indicator of switching on the trailer turn indicators (green);
- 7 – light indicator of switching on the tractor turn indicators (green);
- 8 – light indicator of application of the parking brake (red);
- 9 – light indicator of application of overvoltage of the on-board electric circuit (red);
- 10 – light indicator of application of the low level of the coolant (yellow);
- 11 – multifunctional indicator;

Principle of operation and purpose of the combined indicator

a) 1 – the speed gauge displays the calculated speed of the tractor on the pointer indicator. The calculated speed exceeds the real one because no tractor skidding is taken into account.

The indicator operated from the signals from the pulse transducers of the rotational speed of the gears of the final drives of the rear left and right wheels of the tractor. The speed readings are generated on the basis of the signal from the sensor fitted on the pinion of the final drive of the wheel rotating at lower speed.

In case of fault of one of the speed sensors, the combined indicator displays the speed readings of the speed gauge on the basis of the signal from the serviceable sensor. The typical fault of the circuits or speed sensors in case of absence of signals from them is presented on the LCD display of the combined indicator as “0” (zero) characterizing the location of the fault, either on the left or on the right (see below).

b) 2 – the engine rotational speed gauge displays the engine crankshaft rotational speed on the pointer indicator.

c) 3 – the PTO rotational speed displays the rotational speed on the PTO shaft on the light indicator.

The PTO rotational speed gauge operates on the basis of the signal from the pulse transducer of the rotational speed mounted above the toothed washer on the PTO tail-piece shaft.

In the programming mode, it is necessary to enter the coefficient ZV value different from 0 (see below), namely, equal to the number of teeth of the PTO tail piece. In this case, the coefficient KV2 (see below) can have arbitrary value, because it is not used in the calculations of the PTO rotational speed.

Depending on the PTO rotational speed, the combined indicator selects automatically the range (from 320-750 or from 750-1250) that is accompanied visually by switching on the backlight of the digital designation of the scale: “540” (4.1) or “1000” (4.2); with this, the threshold values of operation of the scale segments change in accordance with the table data;

The five LED segments of the PTO scale (3.1 ... 3.5) are switched on starting from the bottom one including the segment with the current value of the PTO rotational speed covered by the range of its glowing.

“540”	“1000”	Segment location on the scale
650	1150	3.1
580	1050	3.2
500	950	3.3
420	850	3.4
320	750 ¹⁾	3.5
¹⁾ rotational speed, at which the scale designation “1000” is switched on		

Notes:

- The “540” scale designation is only switched on in the presence of the signal from the sensor and off on switching the “1000” designation on or in case of absence of a signal from the PTO rotational speed sensor for more than 3 seconds.
- The exact value of the PTO rotational speed can be seen on the LCD (11) of the multifunctional indicator (hereinafter referred to as the MI); for the description of the MI operation, see the PTO rotational speed mode below.

d) The multifunctional indicator (MI) 11 is a LCD showing the information in the two fields simultaneously:

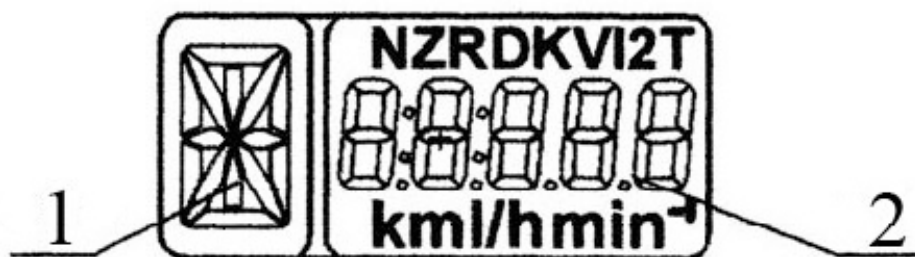

1 – numerical designation of the position of the gearbox switch (digits from 0 to 6) or alphabetical designation of the reduction gear switch position (letters L, M, H and N);

2 – current numerical value of one of the parameters of the tractor systems.

The combined indicator receives the information on the position of the transmission control unit (if the complex electronic control system is provided) or from the range reduction gear control unit (if installed). This parameter is displayed in the information field “1”. In case of absence or disconnection of the control units or wire breakage, the letter “A” is displayed in the information field “1”.

The following parameters are displayed in the information field “2”:

- Total astronomical time of running of the engine;
- Instant fuel consumption;
- On-board power supply system voltage;
- Volume of the fuel remaining;
- Time of work with the remaining fuel;
- Diagnostics of serviceability of the speed sensors;
- Diagnostics of serviceability of the frequency-type fuel volume sensor (FFVS);
- Diagnostics of serviceability and connection of the CAN-bus to the combined indicator.

The switchover between the indication modes: “Total astronomical time of running of the engine”, “Instant fuel consumption”, “Remaining fuel volume”, “Time of work with the remaining fuel” and “On-board power supply system voltage” and fault messages is performed by means of the “Mode” button of the indicator control panel. The description of the operating modes “Diagnostics of serviceability of the speed sensors”, “Diagnostics of serviceability of the frequency-type fuel volume sensor (FFVS)” and “Diagnostics of serviceability and connection of the CAN-bus to the CI” is presented below).

1. Total astronomical time of running of the engine.



The counter accumulates the information on the total time of running of the engine when transmitting the message "engine rotational speed" from the engine control unit and saves the same on stopping the engine. The reading range is from 0 to 99,999 hours of

the engine running.

2. Instant fuel consumption

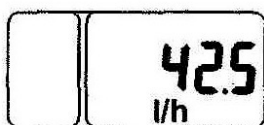

In this mode, the current value of the instant fuel consumption is displayed; the resolution of the reading is 0.1 l/hour.

3. On-board power supply system voltage

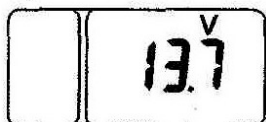

In this mode, the current on-board power supply system voltage is displayed.

4. Remaining fuel volume

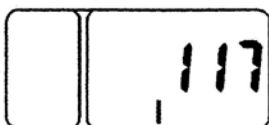

In this mode, the current volume of fuel in the tank (in litres) is displayed.

This mode is only available on the stopped tractor (in the absence of signals from the speed sensors).

Note: To improve the accuracy of display of the fuel volume in the tank, it is necessary to stop the tractor on a horizontal surface.

5. Time of work with the remaining fuel

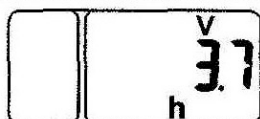

In this mode, the predicted time of work of the engine calculated for the current values of the instant fuel consumption and remaining fuel.

6. PTO rotational speed:

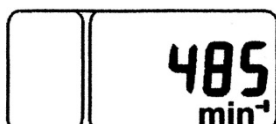

In this mode, the PTO rotational speed is displayed in the digital form depending on the signal from the PTO rotational speed sensor.

CI in the fault message display mode

1. Diagnostics of the serviceability and connection of the speed sensors:

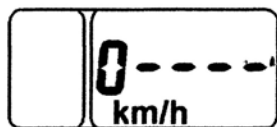

Left-wheel sensor

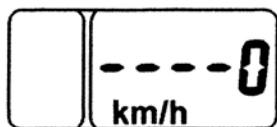

Right-wheel sensor

In case of absence of the signals from the speed sensors for 10-12 seconds, the message in the form of the digit “0” (zero) characterizing the faulty sensor location (left or right).

2. Diagnostics of serviceability of the frequency-type fuel volume sensor (FFVS):



In case of absence of the frequency-type signal from the FFVS for 2 seconds, the “FUEL” message is shown on the LCD for 2 seconds;

3. Diagnostics of serviceability and connection of the CAN-bus to the CI c CAN-interface:

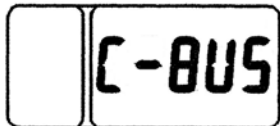

The absence of the signals over the CAN-bus (CI) is accompanied by the message “C-BUS”;

Each fault message (**Example:** 0---, FUEL, C-BUS) is displayed by priority on the LCD regardless the information displayed. When pressing the “Mode” button, the messages shall be scrolled in turn. When viewing the last message and repeated pressing the “Mode” button, the LCD is switched to the display mode over the cycle of the preliminarily specified work parameters.

The fault messages are displayed on the LCD each time the instrument is switched on till the moment of elimination of the cause of the fault.

Notes:

1 – On switching on the CI, the information is displayed on the MI in the indication mode selected before switching off the CI power supply.

2 – In the absence of the information on the vales of the parameters received from the engine control unit only, the respective indication modes are switched off automatically.

Light indicators of the combined indicator

ATTENTION! The light indicators are switched on and off synchronously with the change of state of the system sensors.

a) 5 – light indicator of the high beam of the headlights. It lights up when the high beam of the headlights is on.

b) 6, 7 – indicators of switching on the turn indicators of the tractor and trailer. It operates in the blinking mode when the signal of the right or left turn is switched on by means of the multi-function control stalk 11 (Figure 2.10) or when the fault signalling is ON.

c) 8 – light indicator of the parking brake application. The “Parking brake” (Стояночный тормоз) indicator blinks at the frequency of 1 Hz when the parking brake application sensor is on;

d) 9 – light indicator of the overvoltage in the on-board power supply system. It lights up when the voltage of the on-board power supply system of the tractor exceeds 19 V and goes out when the power supply voltage level drops down to 17 V;

In this case the CI is fully de-energized and restores its serviceability when the voltage drops down to the rated value of the on-board power supply system.

e) 10 – light indicator of the low coolant level. It lights up when the coolant level in the expansion bottle drops below 20% from the total level.

Description of the checking the functioning of the instruments

Each time the combined indicator is energized, the pointer indicators and elements of the PTO indicator scale elements are tested. When it is done, the pointers of the indicators deflect from the initiate marks over the following first quantized marks of the scales (over “5” for speed and “10” for rpm) and all the segments and designations “540” and “1000” of the PTO scale light up.

Programming board of the combined indicator

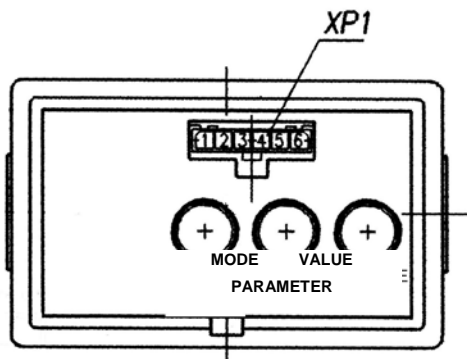

The programming board makes it possible to perform the manual programming of the combined indicator by means of the “Parameter” (Параметр) and “Value” (Значение) buttons and to modify the mode of display of the parameters to be shown on the LCD.

Note: The diagnostic connector **XP1** located on the front panel of the control board makes it possible to perform the automatic programming (reprogramming) of the CI by means of a special instrument (if provided). Should such an instrument be unavailable, the programming shall be performed by means of the above buttons. On the BELARUS-1523/1523B/1523.3/1523B.3 tractors, the XP1 connector is not enabled.

CI programming procedure

1. On selecting the fixed value of the programming parameter:
 - 1.1. On pressing the “Parameter” (Параметр) button for the first time, the LCD is switched to the mode of viewing the parameter to be programmed and its numerical value. On pressing this button repeatedly, the parameters are switched over cyclically.
 - 1.2. On pressing successively the “Value” (Значение) button, the numerical value of the set parameter to be programmed changes.
 - 1.3. The mode is exited automatically if neither “Parameter” (Параметр) nor “Value” (Значение) button has been pressed within 7.0 sec.
On exiting the mode, the last values of the parameters selected by the “Value” (Значение) button are saved.

2. When entering the unfixed value of the programming parameter:
 - 2.1. Select the parameter, the values of which shall be set, by means of the “Parameter” (Параметр) button;
 - 2.2. Press twice the “Mode” (Режим) button; the least digit of the numerical value starts blinking;
 - 2.3. To change the value of the blinking digit of the parameter, use the “Value” (Значение) button;
 - 2.4. To go to the more significant digit, press the “Parameter” (Параметр) button;
 - 2.5. To exit the mode of programming an unfixed value of any parameter, press twice the “Mode” (Режим) button;
 - 2.6. On exiting the above mode, the digits of the entered value of the parameter become lit steadily;
 - 2.7. The newly entered value is set the last in the list of the parameter values allowed to be programmed;





Note:

- If the “Mode” (Режим) button is pressed once in the programming mode, it is impossible to enter an arbitrary value of the parameter;
- Should none of the buttons “Mode” (Режим), “Parameter” (Параметр), “Value” (Значение) be pressed within seven seconds in the mode of entering the unfixed value, the CI will be switched automatically to the basic LCD operation mode with saving the set values of the parameters.

It is allowed to enter one unfixed value within the range:

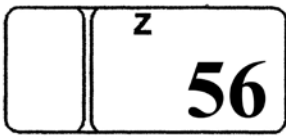
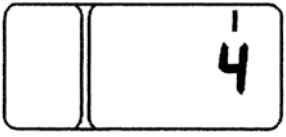
- for “Z”: from 23 to 69;
- for “I”: from 1.000 to 4.000;
- for “R”: from 400 to 1000;
- for “K”: from 2.360 to 4.000 (for a CI without CAN-interface)
- for “KV2”: from 0.346 to 0.600;
- for “ZV”: from 12 to 78;
- for “V”: from 0 to 600.

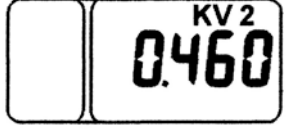
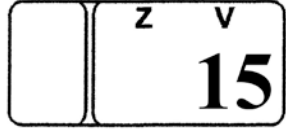
List of programmable coefficients (graphical examples of displaying the parameters and their values in the programming mode):

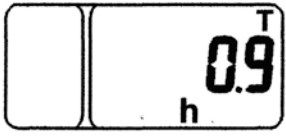
	<p>Parameter "Z"</p> <p>Z is the number of teeth of the pinions of the final shafts of the driving wheels (right and left), over which the (rotational) speed sensors are installed.</p>												
	<p>Parameter "I"</p> <p>I is the multiplying factor of the gear rate of the wheel reduction gear.</p>												
	<p>Parameter "R"</p> <p>R is the rear wheel rolling radius, mm. When reprogramming, this parameter can be varied with the step of 5 mm.</p> <p>Note: 830 is the value for the tyres 520/70R38. In case of fitting other types of tyres, it is necessary to set the value of the parameter "R" corresponding to the rolling radius of the tyres fitted.</p> <table border="1" data-bbox="496 972 1238 1115"> <tr> <td>Tyre</td> <td>520/70R38</td> <td>18.4R38</td> <td>11.2R42</td> </tr> <tr> <td>R_k, m</td> <td>0.828</td> <td>0.829</td> <td>0.750</td> </tr> <tr> <td>Number to be coded</td> <td>830</td> <td>830</td> <td>750</td> </tr> </table>	Tyre	520/70R38	18.4R38	11.2R42	R _k , m	0.828	0.829	0.750	Number to be coded	830	830	750
Tyre	520/70R38	18.4R38	11.2R42										
R _k , m	0.828	0.829	0.750										
Number to be coded	830	830	750										
	<p>Parameter KV2</p> <p>KV2 is the reduction ratio of the PTO shaft.</p> <p>Note: The coefficient KV2 can have an arbitrary value for tractors because it is not used in the calculation of the PTO rotational speed</p>												
	<p>Parameter ZV</p> <p>ZV is the number of teeth of the washer of the PTO rotational speed sensor</p>												
	<p>Parameter «V»</p> <p>V is the fuel tank volume, l.</p> <p>Note: Only the volume of the side fuel tank shall be entered (250 litres), respectively, the information on the time of work with the remaining fuel is formed without taking into account the volume of the fuel in the tank located under the cab (the volume of which is 120 litres)</p>												
	<p>Also, when pressing the "Parameter" (Параметр) button in the programming mode, the list of programmable parameters shows the independent parameter "T" of the accurate content of the counter of the total astronomical time of running of the engine in hours. This parameter is unavailable for measuring; it is an accurate value (to 1/10 hours) of the time of running of the engine.</p>												

In the process of operation, it is permitted to vary the values of the parameter “wheel rolling radius R”, which is determined on the basis of the tyres fitted on the tractor wheels by measuring the distance from the wheel centre to the bearing surface.

IT IS PROHIBITED to vary the entered values of the other parameters (factory settings).

On switching on the backlight of the instrument scales, i.e. on moving the central light switch of the position II “The dashboard backlight and marker lights are ON” and position III “The consumers of the position II and road headlights are ON”, the brightness of illumination of the MI display and PTO indicator segments.

Pilot lamp unit (11)

The pilot lamp unit includes five lamps.

Arrangement of the pilot lamps:

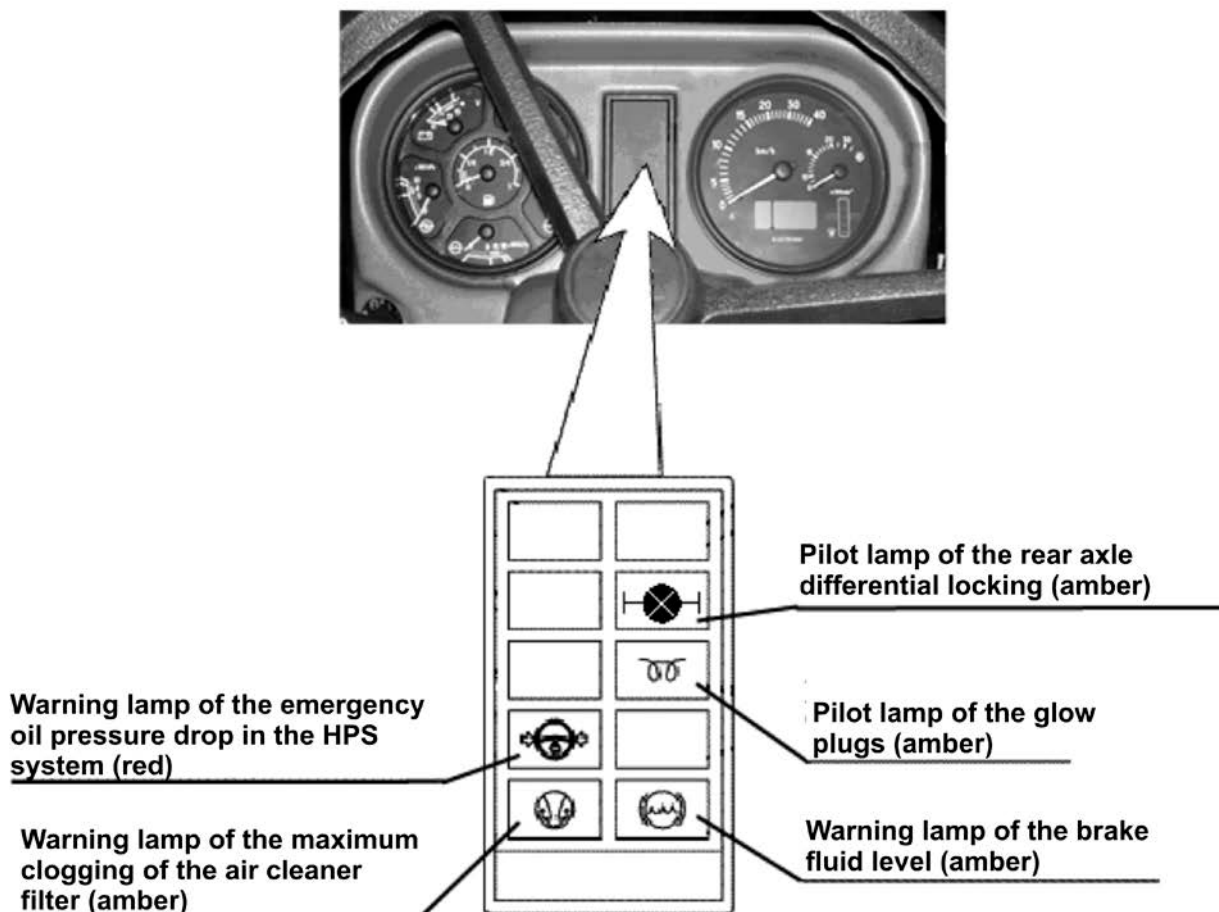

Principle of operation of the pilot lamps:

- a) The warning lamp of the emergency oil pressure drop in the HPS lights up when the oil pressure in the hydraulic system of the HPS drops below 0.08 MPa;
- b) The warning lamp of maximum clogging of the air cleaner filter lights up when the maximum permissible level of clogging is exceeded and its cleaning is necessary;

- c) The rear axle differential locking pilot lamp lights up when the rear axle differential locking is applied;
- d) The warning lamp of the brake fluid level lights up when the brake fluid level in the reservoirs of the master brake cylinder drops below the permissible one;
- e) The glow plug pilot lamp indicates the operation of the glow plugs.

Switch Block (16). Six switches are fitted in the box: heater fan, floodlights (front and rear), rear window wipers, "Road train" signal lights.

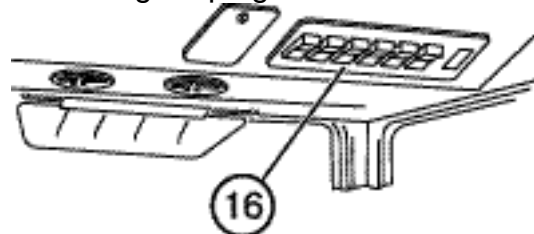

Cab Heater Fan Selector Switch

The switch has three positions:

1. OFF.
2. 1st operational regime (low air supply).
3. 2nd operational regime (high air supply).

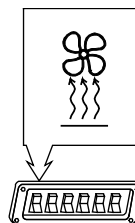

Front Floodlights Switch

On depression of the key-switch, front floodlights and key light indicators are turned ON.

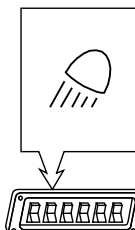

Rear Floodlights Switch

On depression of the key-switch, rear floodlights and key light indicators are turned ON.

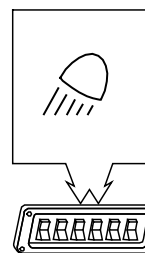

Rear Window Wiper

The switch has three positions:

1. OFF.
2. Wiper is ON.
3. Wiper is ON and non-fixedly the window washer.

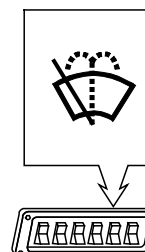

"Road train" Sign Light Switch

When the key is pressed, the road train signal and the indicator key lamp light up.

NOTE: The operation of the air conditioner is described in the section "Construction and Operation".

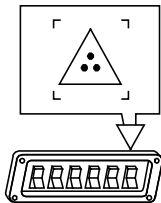

Fuses

A box of safety primary fuses is mounted under cover “A”. Five plug fuses protect the following electric circuits from over-load:

1. Cab dome light and “Road train” sign (7.5 A).
2. Rear window wiper and washer (7.5 A).
3. Cab ventilation and heating system (25 A).
4. Two pairs of rear floodlights (25 A).
5. Two pairs of front floodlights (25 A).
6. Reserve (15 A).

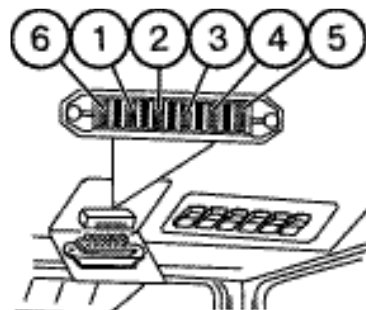
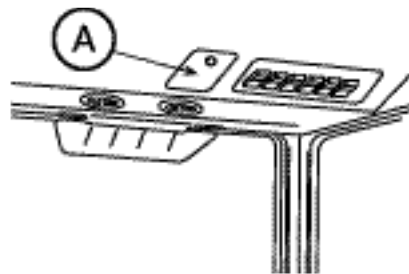

Cab Door Lock (17)

The handle (A) serves to open the cab door: the lock opens by pulling the handle towards you.

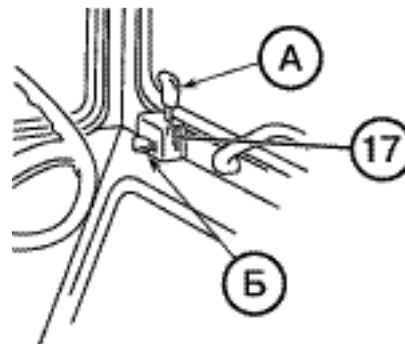

Steering Wheel (18)

1. The position of the steering wheel can be changed in height within the span of 100 mm.

To perform the adjustment, proceed as follows:

- Remove the cover (2);
- Turn out the clamp (1) by 3...5 turns;
- Pull or push the steering wheel (18) to the position being convenient for you;
- Tighten the clamp and refit the cover.

2. The tilt of the steering column is adjustable within the range from 25° to 40° with the increments of 5°. To change the steering column tilt, pull the handle (23) and tilt the column with the steering wheel to the required position, release the handle and slightly turn the column to the fixed position.

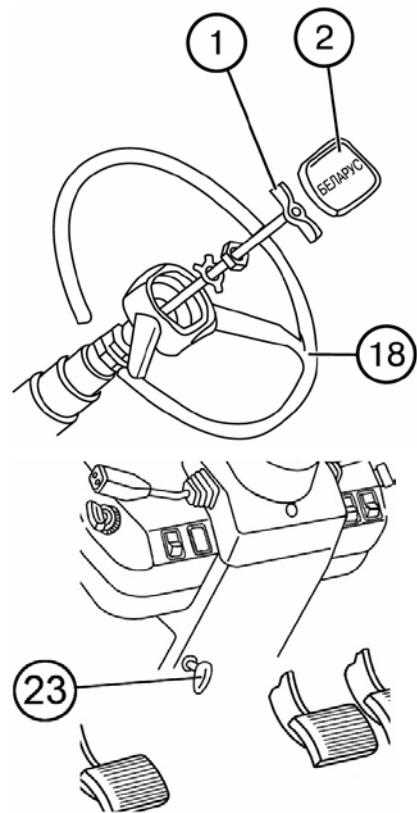

Multi-Function Handle-Switch, Right-Hand (20) assures:

- switching on the two-speed electric windscreen wiper;
- switching on the windscreen washer.

To turn the windscreen wiper ON, shift the switch lever from the OFF position (rear-most position “0”) forward to the position “I” (first speed) or “II” (second speed). All the positions are fixed.

The windscreen washer is turned ON (non-fixed position) by moving the switch handle upward from any of the three above-mentioned positions of the switch.

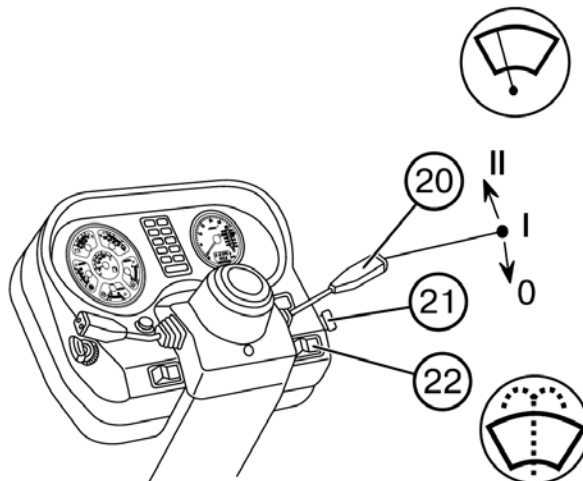

Fault signalling Push-Button (21)

With the push-button (21) depressed, the alarm fault signalling system is energized. At the same time, a warning lamp built into the push-button starts to flicker, in unison with the flickering lights of the alarm system.



Central light switch (22)

The switch has three positions:

1. OFF. The right-hand part of the key is to be depressed.
2. The front and rear marker lights, instrument illumination, number-plate light, trailed/mounted machine marker lights and additional floodlights, and data processing and display unit are energized. Middle position.
3. All loads specified under item “2” plus the headlights are ON. The key left-hand side is to be depressed.

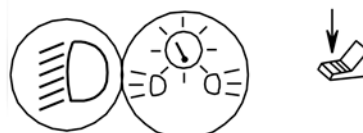
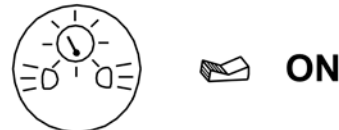

Safety Fuse Blocks

Two blocks of electric circuit safety fuses БП-1 and БП-2 are mounted under the dashboard.

To gain access to the safety fuses, turn out the screw (A) and remove the cover (B). Eleven safety primary fuses protect the following electric circuits from overload:

БП-1:

- 1 – instrumentation supply (15 A);
- 2 – turn-signal light interrupter (7.5 A);
- 3 – right-hand headlight low beam (7.5 A);
- 4 – left-hand headlight low beam (7.5 A);
- 5 – right-hand marker lights and dashboard backlight (15 A);
- 6 – left-hand marker lights (7.5 A).

БП-2:

- 1 – headlight high beam (25 A);
- 2 – horn (15 A);
- 3 – fault signalling light (15 A);
- 4 – fault signalling light (15 A);
- 5 – windscreen wiper and washer (15 A);
- 6 – stop light (15 A).

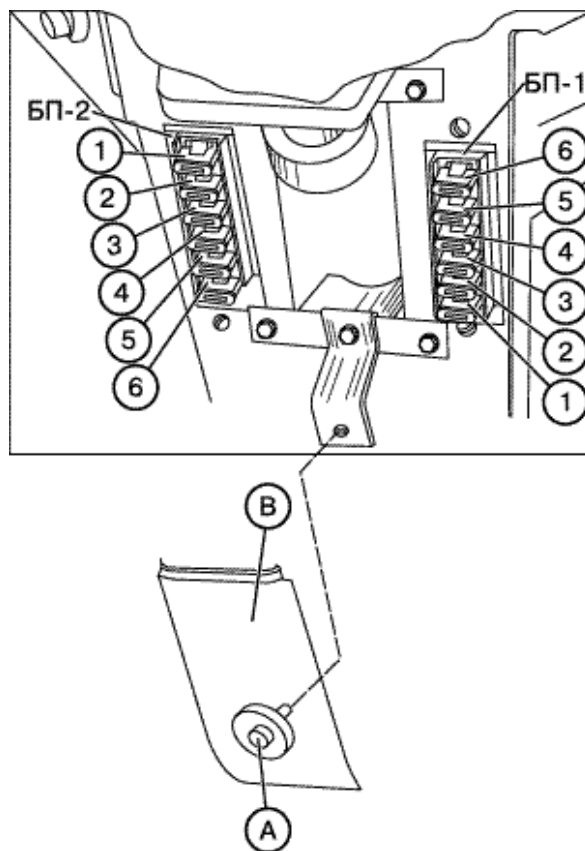

WARNING! To prevent the tractor electric wiring from burning, **NEVER** use the fuses with ratings exceeding those specified above. If a safety fuse gets blown out frequently, find out the cause and rectify the fault before fitting a new one.

Electrical equipment connecting elements

A combined multi-function socket is provided for connecting the current-consuming loads of a trailer or trailed agricultural implements, as well as a portable inspection lamp. The socket is installed externally on the rear cab wall.

The socket is designed to be plugged in with the wire braid assembly connectors and portable lamp jack-plug.

Marking the socket terminals:

- 1 – stop light;
- 2 – left-hand turn signal;
- 3 – left-hand marker light;
- 4 – audible signalling device;
- 5 – battery disconnect switch;
- 6 – right-hand turn signal;
- 7 – right-hand marker light;
- 8 – socket for plugging in a portable lamp.

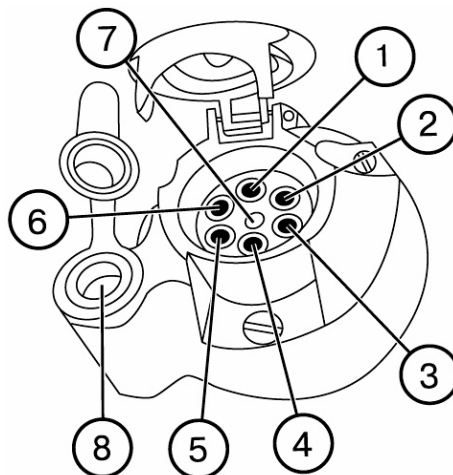

BELARUS 1523/1523B

Gear-shift lever (27)

The gear-shift diagram is shown in the figure on the right, top.

Range selector lever (28)

The range change-over diagram is shown in the figure on the right, bottom.

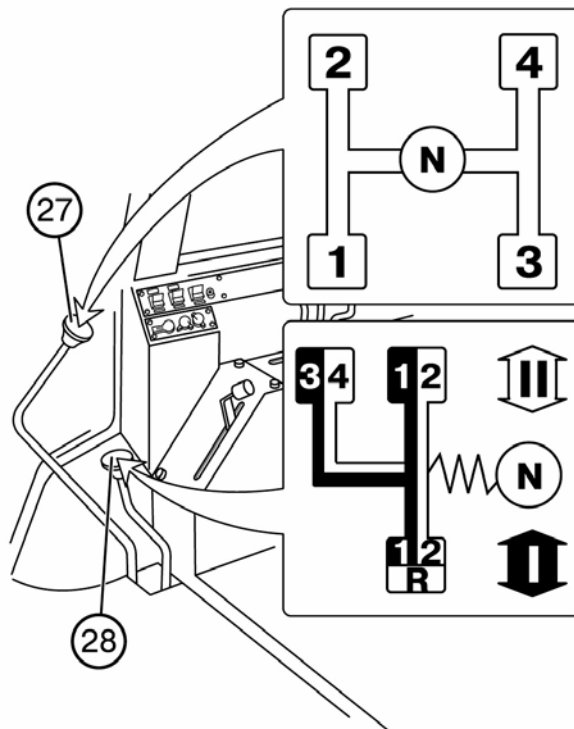

BELARUS-1523.3/1523B.3

Gear-shift lever (27)

The gear-shift diagram is shown in the figure on the right (Diagram I).

Pushbutton (27a) for engagement of the lowest stage (L) of the GB reduction gear.

Pushbutton (27b) for engagement of the highest stage (H) of the GB reduction gear.

Range selector lever (28)

A change-over diagram is shown in Figure on the right (Diagram II).

Fuel Feed Control Handle (29)

Pushing the handle in the direction of tractor head-on movement increases the fuel feed and vice versa. The rearmost position of the handle corresponds to minimum idling rotational speed.¹

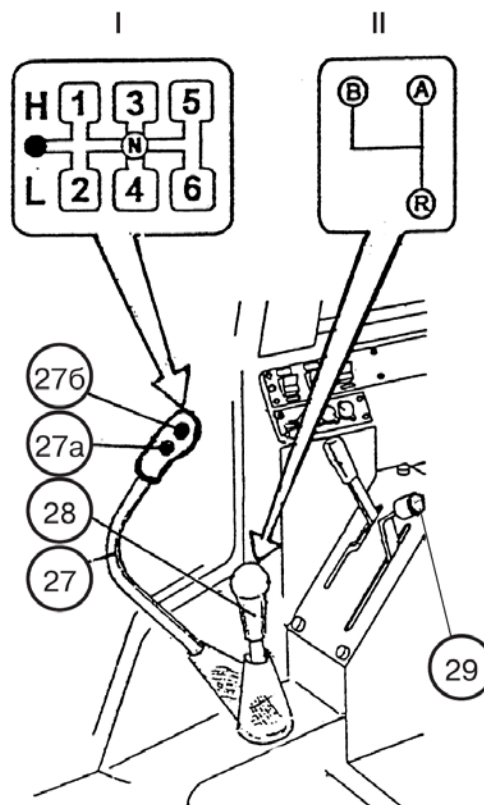

PTO operating lever (30)

The lever has two positions:

- Position “T” (brake): outermost rear top position, the PTO is disengaged and the tail-piece is braked.
- Position “F” (friction): outermost front bottom position, the PTO is engaged and the tail-piece rotates;

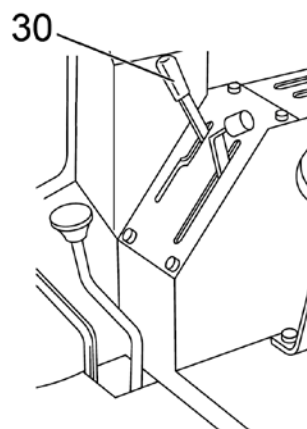

HLL Control Panel (31)

(see section “Construction and Operation”)

¹ For stopping the engine or emergency shut-down of the same, an additional handle is provided.

Control panel of the differential lock, FDA and front PTO shaft (32) (if installed)

The control of the dumping mode shall be only exercised by means of the button located on the RHL control panel (see section “Construction and Operation”). The variant of mounting of the key

for controlling the dumping mode on the control panel of the differential lock, FDA and front PTO is not used on the tractors.

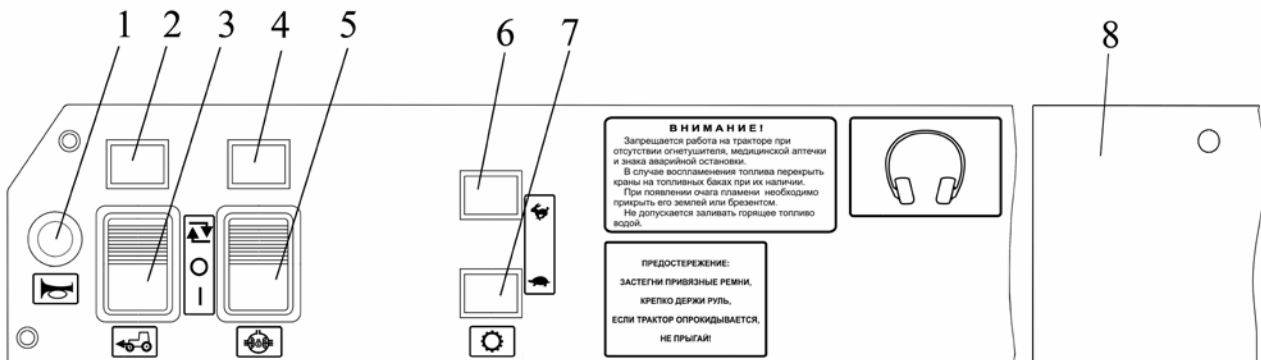

Panel of the control unit of the differential lock and FDA (if the front PTO is not installed)

1 – horn push pad; 2 – pilot lamp of engagement of the FDA drive; 3 – FDA drive control switch; 4 – pilot lamp of the differential lock application; 5 – differential lock control switch; 6 – pilot lamp of the highest stage of the GB reduction gear; 7 – pilot lamp of the lowest stage of the GB reduction gear; 8 – fuse block cover.

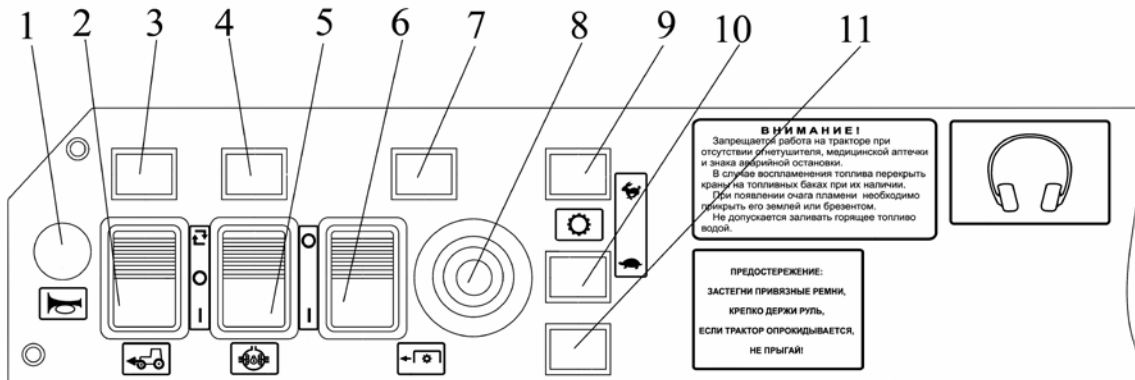

Panel of the control unit of the differential lock, FDA and front PTO

1 – horn push pad; 2 – FDA drive control switch; 3 – pilot lamp of engagement of the FDA drive; 4 – pilot lamp of the differential lock application; 5 – differential lock control switch; 6 – front PTO control switch; 7 – pilot lamp of engagement of the front PTO; 8 – front PTO engagement button; 9 – pilot lamp of the highest stage of the GB reduction gear; 10 – pilot lamp of the lowest stage of the GB reduction gear; 11 – choke.

Note: purpose and principle of operation of the elements of the panel of the control unit of the differential lock, FDA and front PTO (if installed) shown in the figures as well as places of their location, purpose and principle of operation of the elements of control of the GB reduction gear and RHL are provided in the section “Construction and Operation”.

Fuses of the electronic control systems of the differential lock, FDA, GB reduction gear, front PTO and RHL

To gain access to the fuses of the electronic control systems, turn out the screw on the cover of the control unit panel and open the cover.

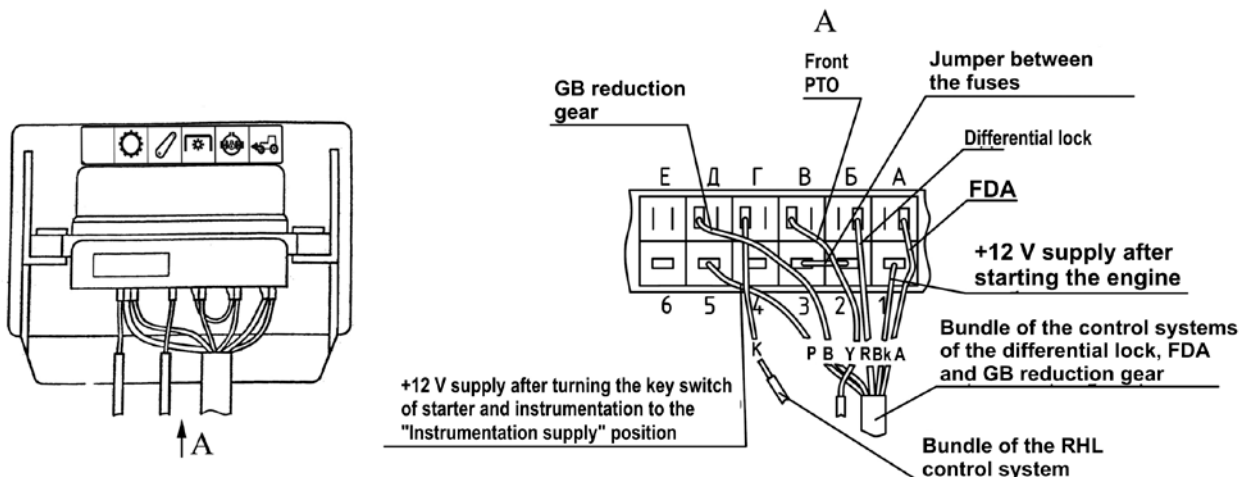

Wire colouring: P – pink; B – blue; Y – yellow; R – red; Bk – black; A – amber

- 1 – FDA drive control (7.5 A);
- 2 – Rear axle differential lock control (7.5 A);
- 3 – Front PTO control (7.5 A);
- 4 – RHL control (7.5 A);
- 5 – GB reduction gear control (15 A);
- 6 – Reserved (7.5 A).

WARNING! To prevent the tractor electric wiring from burning, **NEVER** use the fuses with ratings exceeding those specified above. If a safety fuse gets blown out frequently, find out the cause and rectify the fault before fitting a new one.

Hydraulic Distributor Control Levers (33a, 33b, 33c)

The control levers are located on the right-hand side panel in the cab. The handles have “neutral”, “drop”, “floating” and “lift” positions.

The handle (33a) controls the left-hand distributor section, if viewed in the direction of tractor running, and the rear left outlets of the hydraulic system. It can be fixed in the “floating” and “neutral” positions.

The handle (33b) controls the middle section of the distributor and the middle rear outlets of the hydraulic system. It can be fixed in the “floating” and “neutral”.

The handle (33c) controls the right-hand section of the distributor and right-hand rear outlets of the hydraulic system. It can be fixed in all the positions except for the “drop” one.

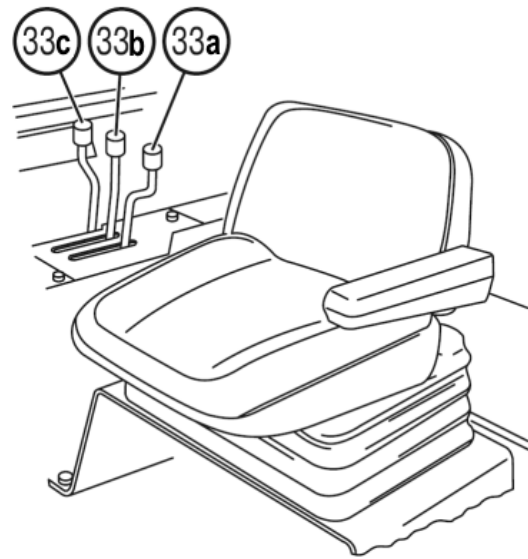

PTO Independent/Synchronous Change-Over Handle (35)

The handle (35) has three positions:

- “Independent PTO Engaged”: uppermost position;
- “Disengaged” (neutral): midposition;
- “PTO Synchronous Drive Engaged”: the extreme bottom position.

Creeper gear control lever (36, 37)

- Creeper gear “Engaged”: the rod (13) is depressed and the rod (12) is lifted;
- Creeper gear “Disengaged”: the rod (13) is lifted and the rod (12) is depressed.

Parking Brake Control Lever (38)

- “Parking brake applied”: top position.
- “Parking brake released”: bottom position.

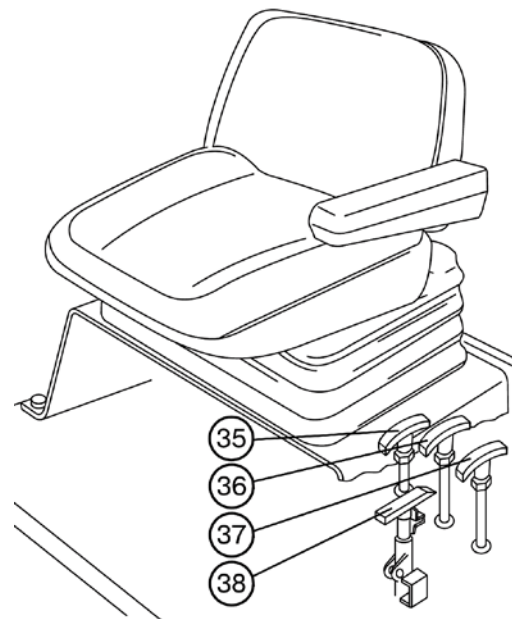

Speed selector of the independent PTO drive (38a) (for tractors with the GB 24x12)

The speed selector of the independent PTO drive (38a) is located on the left of the clutch casing and has two positions:

- I – 540 and 1000 rpm: counter-clockwise up to the stop;
- II – 651 and 1435 rpm: clockwise up to the stop.

To set the necessary PTO speed, loosen the bolt (A), turn the lever and tighten the bolt (A).

GB Pump Control Lever (39)

The lever has two fixed positions:

- I – “Engine Driven Pump”: the lever (39) is turned counter-clockwise till it locks and fixed with a bolt (A);
- II – “Non-operating position”: the lever (39) is turned clockwise till it locks.

Working position of the lever: Pump drive from the engine” (the bolt (A) is tightened).

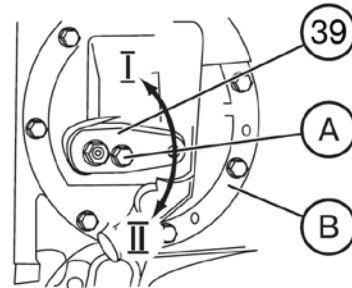

NOTE. When it is necessary to remove the cover (B), set the lever (37) to its non operating position II. On fitting the cover, return the lever to position I and fix it with the bolt (A).

Compressor Drive Release Handle (40)

The compressor control handle has two positions as follows:

- “Compressor ON”: the handle (40) is set with the arrow directed to the right (towards the cab);
- “Compressor OFF”: the handle is set with the arrow directed to the left.

Turn the compressor ON when the engine is shut down or running at the minimum idling rpm.

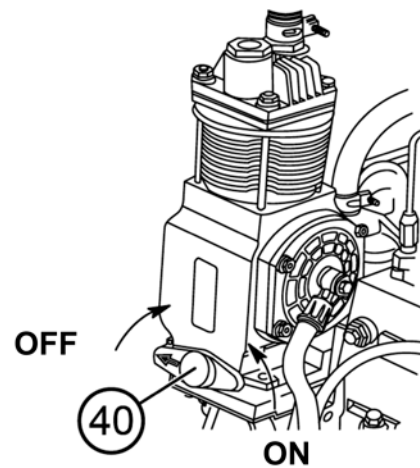

HLL pump engagement spindle (41)

The spindle has two positions:

- “Pump ON”: the spindle is turned clockwise against the stop;
- “ Pump OFF”: the spindle is turned counter-clockwise against the stop.

Prior to turning the spindle (41) to any of the two positions, loosen the bolt (43) by 1.5...2 revolutions and turn the spindle (41) together with the stop plate (42). Tighten the bolt (43).

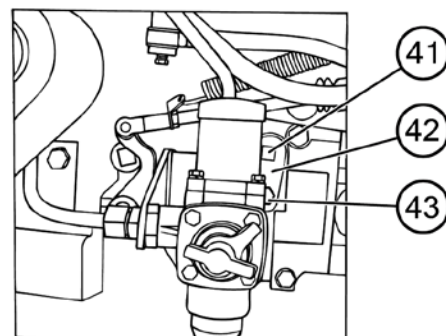

HLL External Control Panels (right-hand and left-hand) (44)

On pressing the top pushbutton “П” (Lift), the RHL is raised and on pressing the lower pushbutton “O” (Drop) it is lowered.

WARNING: When using the external control panels, keep well away from the attached machine (implement), to avoid severe injuries.

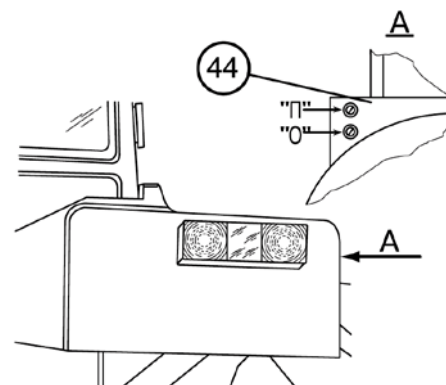

TRACTOR REVERSIBLE OPERATION POST (BELARUS 1523B/1523B.3)

These tractors are provided with a reversible control post to extend their gang-up capability with the front-end mounted agricultural machinery.

Reversible operation control elements:

- additional rear steering column with a metering pump;
- duplicated pedal drives for the clutch, brakes and fuel feed;
- operator's seat reversal mechanism;
- extra horn push pad and emergency engine operation mode warning device;
- reverse cock.

ATTENTION!

1. The reversible operation post of the tractor is intended for use only when performing field operations while running in reverse.
2. Make sure you have interlocked the forward-movement brake pedals prior to running in reverse.
3. NEVER drive the tractor in reverse on public roads or when performing jobs not associated with agricultural farming, as well as when loading/unloading the tractor proper.

Controls of the Reversible Operation post

Additional controls are installed in the rear part of the cab. The figure on the right illustrates their relative arrangement.

- 1 – Clutch pedal. Stepping on the pedal disengages the clutch. Removing the foot from the pedal re-engages the clutch.
- 2 – Tractor steering wheel (rearranged from the forward movement column (9)).
- 3 – Brake pedal. Stepping on the pedal applies both the tractor brakes and pneumatic actuator of the trailer brakes.
- 4 – Fuel feed control pedal. When depressed, the fuel feed increases.
- 5 – Horn push pad.
- 6 – Fuel feed control lever. The rear-most position (in reverse) corresponds to the maximum fuel feed while the foremost position – to the engine shutdown.
- 7 – GB range selector lever (refer to Shifting Diagram I).
- 8 – GB gear-shift lever (refer to Shifting Diagram II).
- 9 – Forward-movement steering column.

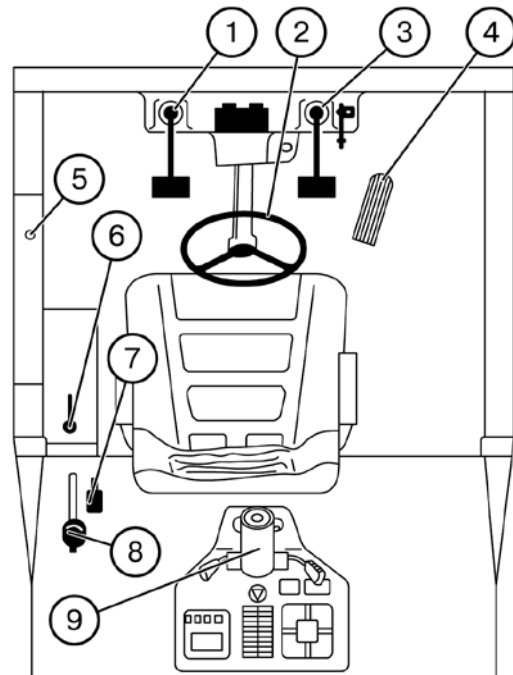

1 – clutch pedal; 2 – steering wheel; 3 – brake pedal; 4 – fuel-feed control pedal; 5 – horn push-pad; 6 – fuel-feed lever; 7 – GB range selector lever; 8 – GB gear-shift lever; 9 – forward-movement steering column.

To drive the tractor in reverse, proceed as follows:

- interlock the forward-movement brake pedals;
- remove the steering wheel from the column and fit it on the additional steering column. To do this, screw off the steering-wheel fixing handwheel, rearrange the steering wheel and fix it at the required height;
- install the reversing seat for operation in the reverse mode;
- Switch the clutch control to the reverse move.

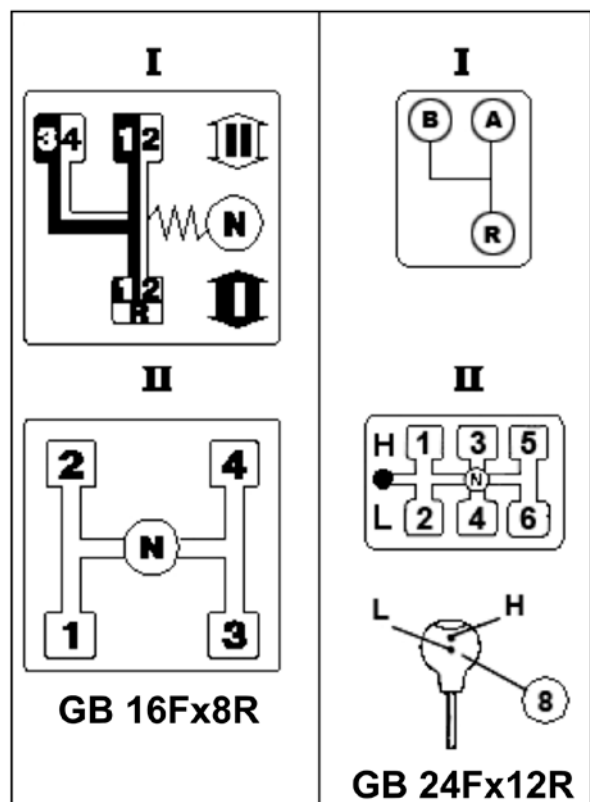

BELARUS Seat

Important! Prior to starting the work on the tractor, adjust the seat to the position being the most convenient for you. Perform all the adjustments while sitting on the seat.

The seat is considered to be adjusted correctly to the operator's weight, if it takes up half of its travel under the operator's weight (suspension travel: 100 mm).

Seat adjustment:

To the operator's weight: from 50 to 120 kg.

It is performed by means of the handle (1). To adjust the seat to a heavier weight, it is necessary to reset the pawl of the handle (1) to the position "A" and to tighten the springs by reciprocating motion. To adjust the seat to lighter weight, it is necessary to reset the pawl to the position "B" and loosen the springs by reciprocating motion.

Back inclination adjustment: from 15° to 20°. It is performed by means of the handwheel (2). To increase the back inclination angle, it is necessary to turn the handwheel clockwise, and to reduce the same – counter-clockwise.

Longitudinal adjustment of the seat: 160 mm. It is performed by means of the handle (3). To move the seat forward or backward, it is necessary to lift and pull the handle, shift the seat and release the handle. The seat will be fixed automatically in the required position.

Height adjustment 60 mm. The seat has three height positions: "bottom", "medium" and "top". To transfer the seat from the "bottom" position to the "medium" one or from the "medium" to the "top" one, it is necessary to lift smoothly the seat until the operation of the click-work (the characteristic click is heard). To transfer the seat from the "top" position to the "bottom" one, it is necessary to lift the seat up to the stop and in an abrupt movement and then drop it.

Note: It is impossible to transfer the seat from the "medium" position to the "bottom" one.

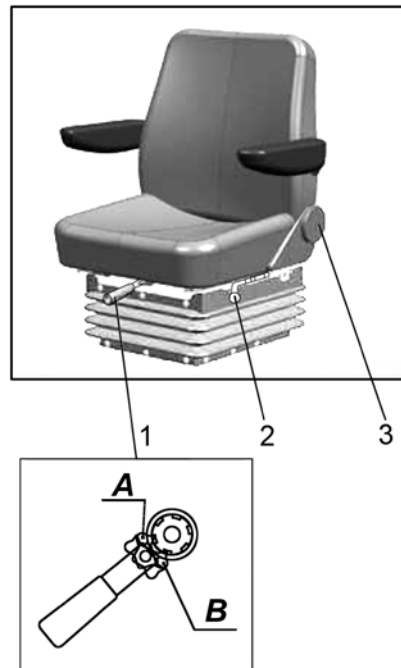

"Reverse" position (for BELARUS-1523B/1523B.3 tractors with reversible control post) To transfer the seat to the "reverse" position, it is necessary to turn out the clamps D and lead them out from the slots of the brackets of the panel E, lift the lever F and turn the seat by 180°. Lift the seat and pull it in an abrupt motion. Lead the screws G into the slots of the brackets of the panel E, turn on the nut I until it rests against the brackets and tighten the clamps I with the torque of 44 ... 56 Nm.

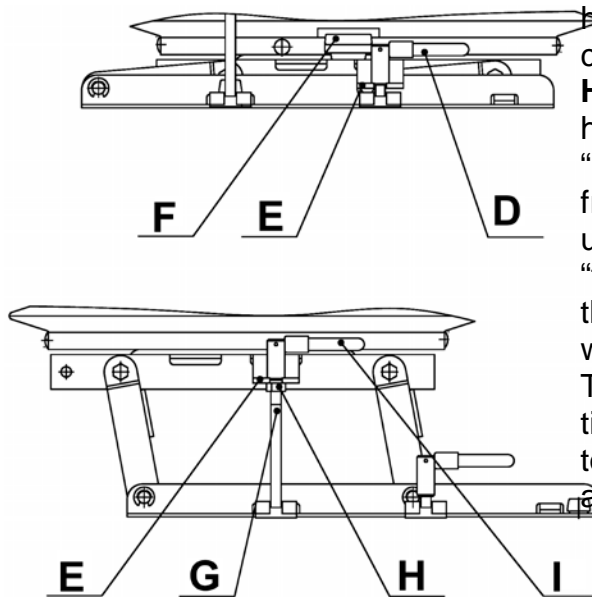

handle. The seat will be fixed automatically in the required position.

Height adjustment 60 mm. The seat has three height positions: “bottom”, “medium” and “top”. To transfer the seat from the “bottom” position to the “medium” one or from the “medium” to the “top” one, it is necessary to lift smoothly the seat until the operation of the click-work (the characteristic click is heard). To transfer the seat from the “top” position to the “bottom” one, it is necessary to lift the seat up to the stop and in an abrupt movement and then drop it.

Grammer MSG85/721 Seat
(if installed)

Important! Prior to starting the work on the tractor, adjust the seat to the position being the most convenient for you. Perform all the adjustments while sitting on the seat.

Seat adjustment:

To the operator’s weight: from 50 to 120 kg with the indication of the weight with the step of 10 kg. It is performed by means of the handle (1). To adjust the seat to a heavier weight, it is necessary to turn the handle clockwise and to adjust the same to a lighter weight – counter-clockwise.

Back inclination adjustment from –10° to 35°. It is performed by means of the lever (2). Lift the lever up to the stop, tilt the back and release the lever. The fix will be fixed in the necessary position.

Longitudinal adjustment of the seat: 150 mm. It is performed by means of the handle (3). To move the seat forward or backward, it is necessary to lift and pull the handle, shift the seat and release the

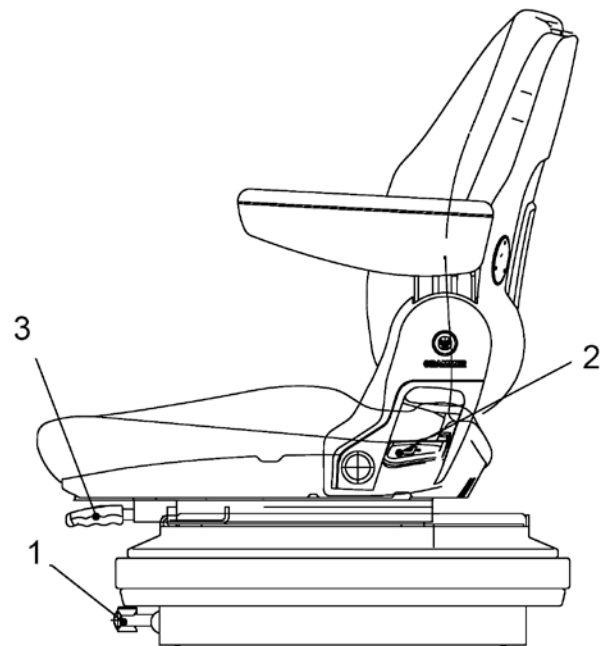

Note: It is impossible to transfer the seat from the “medium” position to the “bottom” one.

CONSTRUCTION AND OPERATION OF TRACTOR COMPONENTS

ENGINE

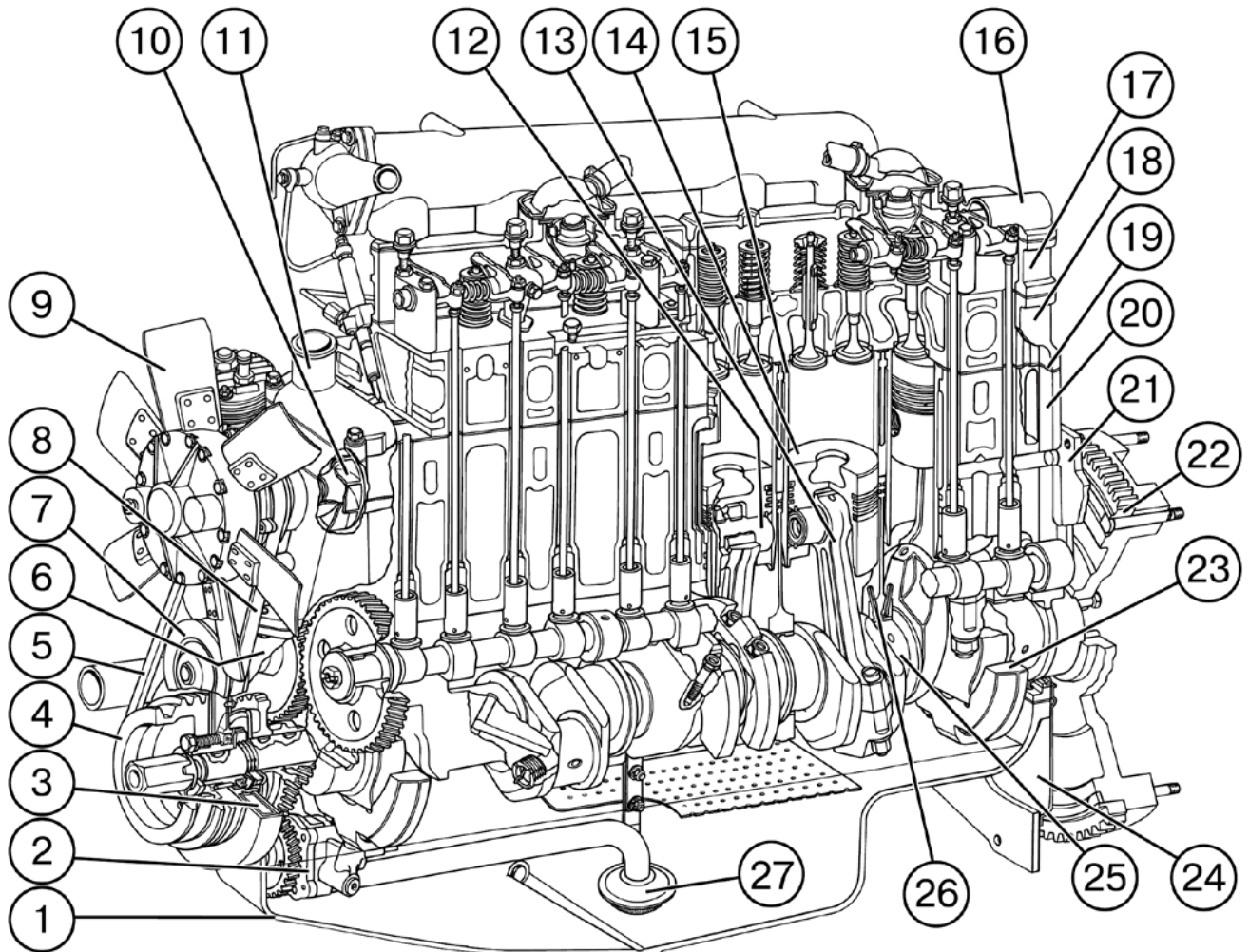

1 – crankcase; 2 – oil pump; 3 – torsional vibrations damper; 4 – crankshaft pulley; 5 – fan driving belt; 6 – valve-timing gearing cover; 7 – tensioning jockey; 8 – alternator driving belt; 9 – fan; 10 – water pump; 11 – thermostats housing; 12 – piston pin; 13 – connecting rod; 14 – piston; 15 – cylinder sleeve; 16 – cap hood (2 off); 17 – cylinder head cover (2 off); 18 – cylinder head (2 off); 19 – cylinder head gasket (1 off); 20 – cylinder block; 21 – rear sheet; 22 – flywheel; 23 – counterweight; 24 – cover; 25 – crankshaft; 26 – piston cooling jet ; 27 – oil pick-up.

The tractor is equipped with a Д-260.1 six-cylinder, in-line, four-stroke turbo-charged, liquid-cooled diesel engine Д-260.1 or Д-260.1S, Д-260.1S2 with direct injection of fuel.

The engine is cranked by an electric starter.

The engine consists of a cylinder block, two cylinder heads, crank mechanism, valve control as well as feed, lubrication, cooling and starting systems and electric equipment.

The Cylinder Block (20) is designed as a monoblock and constitutes a rigid iron casting.

Six replaceable sleeves (15) made of special cast iron are installed in the cylinder block bores.

The sleeve is installed in the cylinder block with referring to two centring belts. At the upper belt, the sleeve is restrained with a shoulder, while at the bottom one it is packed with two rubber rings.

At the bottom, the cylinder block is closed with a crankcase (1) cast of aluminium alloy.

The two interchangeable **Cylinder Heads** (18) (one per three cylinders) are iron cast.

The cylinder heads are fitted with insertion valve seats made of high-temperature and abrasion-resistant alloy. The injectors (14) (three pieces per each cylinder head) are mounted in the cylinder heads.

The sealing of the cylinder head-to-engine block joint is ensured by the

gasket (19) made of asbestos-steel cloth. The bores for the cylinder sleeves and the oil passageway are edged with sheet steel. When assembling the engine at the manufacturing plant, the cylinder holes in the gasket are additionally edged with fluoroplastic rings.

The Crank Gear includes a crankshaft (25), together with main- and connecting-rod bearings, a flywheel (22), pistons (14) assembled with piston rings and pins, and connecting rods (13).

The Crankshaft is made of steel, supported on seven bearing saddles and fitted with counterweights. The crankpins are provided with pockets intended for additional centrifugal cleaning of oil. These are closed with threaded plugs.

The front-end of the crankshaft is fitted with the pinions for driving the valve control and oil pump, pulley for driving the water pump, alternator and air-conditioner compressor (if installed).

To reduce the amplitude of torsional vibrations of the crankshaft, the pulley is equipped with a liquid-type vibration damper (3).

The **Piston** is made of aluminium alloy. A combustion chamber is made in the piston crown. Three compression piston rings and one oil wiper ring with an expander are installed in the upper part of the piston. The top compression piston ring is of a trapezoidal section, the other two compression rings are taper-faces. A "non-resistive" spacer is installed under the top ring.

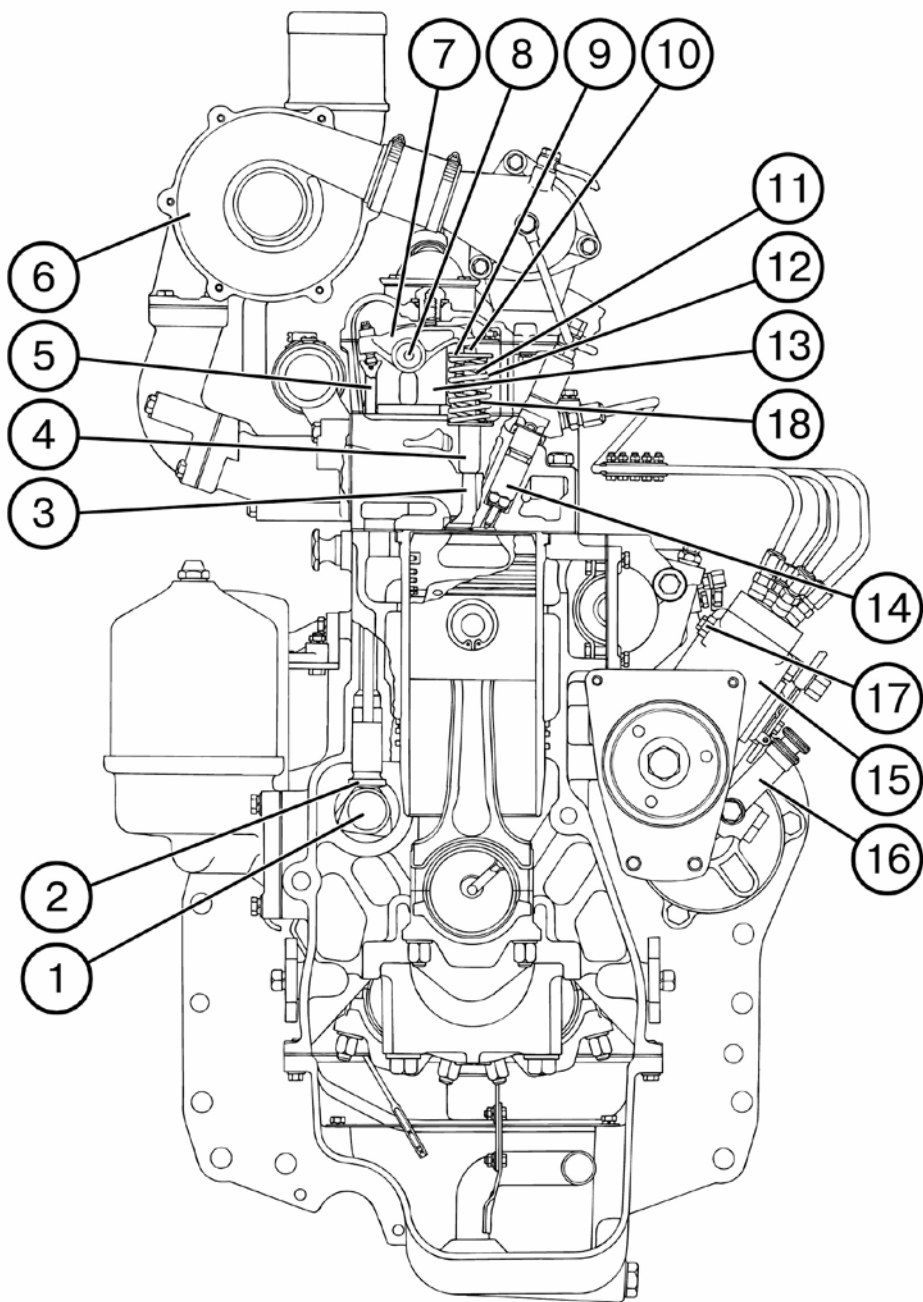

1 – camshaft; 2 – tappet; 3 – valve; 4 – valve guiding bush; 5 – pushrod; 6 – turbocharger; 7 – rocker arm; 8 – roller; 9 – spring retainer (disk); 10 – split cones; 11 – inner spring; 12 – outer spring; 13 – support; 14 – injector; 15 – fuel pump¹; 16 – fuel hand booster-pump; 17 – plug for bleeding air from the fuel pump head; 18 – sealing collar.

The Connecting Rod is an I-section steel part, with a bushing pressed into its top end. For lubricating the piston pin, the top end of the connecting rod and the

bushing are provided with drilled passages. The bottom end consists of the bottom part of the rod and the cap which bear the same markings. The connecting

¹ Instead of a fuel pump of distributive type shown in the figure, the engines are equipped currently with in-line fuel pumps “YAZDA” or “Motorpal”

rod caps are not interchangeable. Besides, the connecting rods have group designations of the mass groups of the top and bottom ends; these are marked on the end-face of the top end of the connecting rod. The engine shall be equipped with the connecting rods of the same group only.

Liners of the Main- and Crankpin Bearings of the crankshaft are thin-walled parts made of a bimetal strip. The liners are manufactured in two sizes as to their inner diameter in accordance with the nominal size of the crankshaft necks.

The **Flywheel** is made of cast iron and bolted to the crankshaft flange. A steel toothed rim is pressed onto the flywheel.

The **Valve Control** consists of the timing gears, camshaft, inlet and outlet valves as well as their fitting and driving parts.

The **Camshaft** is driven from the crankshaft through valve timing gears and rides on four supports.

The **Tappets** (2) are steel members with spherical bottoms. The camshaft cams are made with a slight tilt; hence, when in operation, the tappets are forced to rotate.

The **Tappet Pushrods** (5) are made of a steel bar. The downwardly concave part of the tappet and the push-rod cup are hardened.

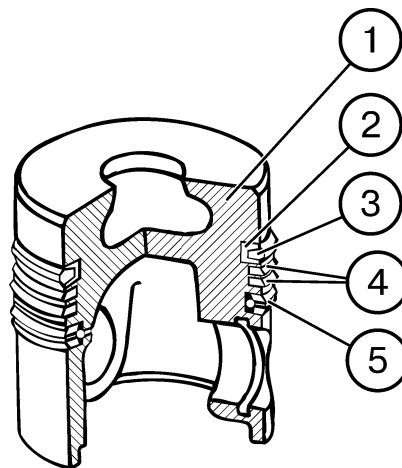

1 – piston; 2 – insert of a “non resist” type; 3 – top compression ring; 4 – compression ring; 5 – oil wiper ring with an expander.

The Valve Rocker Arms (7) are made of steel and rock on the rollers installed in supports. The rocker-arm roller is hollow, with six radial bores for arm lubrication. Displacement of the rocker arms along the roller is restricted by spreader springs.

The Inlet and Outlet Valves (4) are made of high-temperature steel and free to move in their guide bushes. The bushes are press-fitted in the cylinder heads. Each valve closes under the force of two springs: the outer (12) and the inner (11), respectively, fixed on its stem by means of a valve spring retainer (9) and valve locating split cones (10).

Sealing collars (18) installed on the valve guiding bushes keep oil from leaking down into the engine cylinders through gaps between the valve stems and the guiding bushes.

The Engine Feed Circuit consists of an air-cleaner, air-delivery conduit, induction/ exhaust manifolds, turbocharger, exhaust muffler, fuel tanks, coarse and

fine fuel filters, fuel pump, injectors as well as fuel-injection (high-pressure) and delivery low-pressure) pipelines.

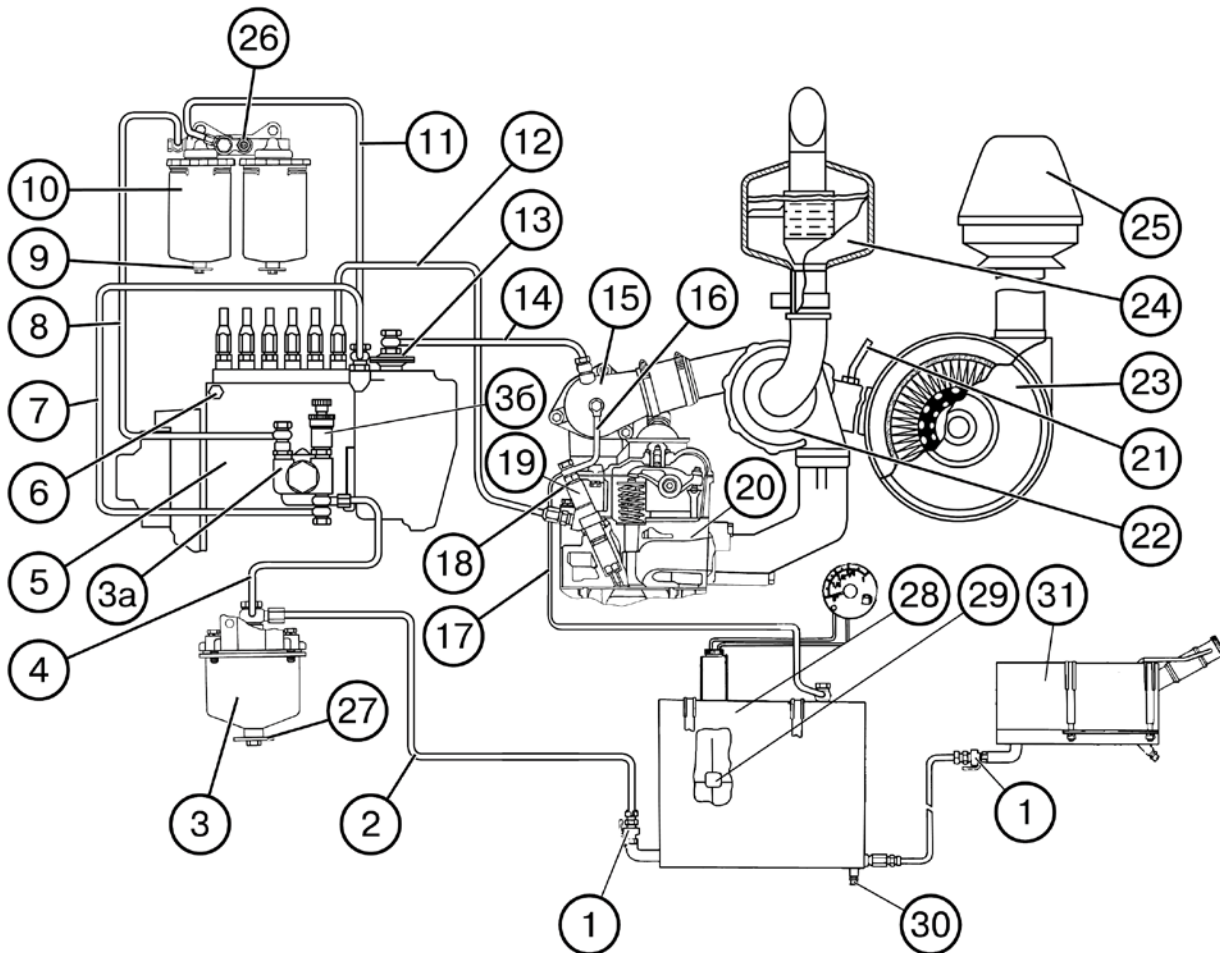

1 – tank stop tap; 2 – connecting pipe from the fuel tank; 3 – coarse fuel filter; 3a – fuel lift pump; 3b –fuel hand-operated booster pump; 4 – connecting pipe from the coarse fuel filter; 5 – fuel pump; 6 – plug to bleed air from the fuel pump head; 7 – fuel offtake pipe from the lower-pressure chamber to the fuel-lift pump; 8 – pipe to deliver fuel from the fuel-lift pump to the fine fuel filter; 9 – sludge draining plug; 10 – fine fuel filter; 11 - fuel offtake pipe from the fine filter to the lower-pressure chamber of the pump; 12 – fuel injection pipe; 13 - pneumatic adjuster; 14 –pipe of air delivery from air-delivery conduit downstream the turbocharger to the pneumatic adjuster; 15 – induction manifold; 16 – fuel overflow pipe; 17 – fuel drain pipeline; 18 – fuel overflow pipe; 19 – injector; 20 – cylinder head; 21 – air-cleaner clogging indicator pipeline; 22 – turbocharger; 23 – air-cleaner; 24 – exhaust muffler; 25 – coarse fuel filter (monocyclon); 26 – air-bleeding plug; 27 – plug to drain sludge; 28 – fuel tank; 29 – fuel level gauge float; 30 – sludge draining nipple; 31 – fuel tank.

The Air Cleaner is a dry-type filter, with paper filter-cartridges. It provides the three-stage cleaning. The first stage is preliminary inertial cleaning (a monocy-clon); the second and third ones are dry cleaning in master (5) and check (4) pa-per filter elements.

To warn of the extent of air-cleaner clog-ging, a warning lamp is installed in the pi-lot lamp cluster of the dash-board. The electric cleaner-clogging sensor operates at the depression of 450 ± 50 mm H₂O in the induction manifold.

The Coarse Fuel Filter with a screen fil-ter element cleans the fuel from mechani-cal impurities and water. The sludge is drained from the filter through a draining plug located in the bottom part of the bowl housing.

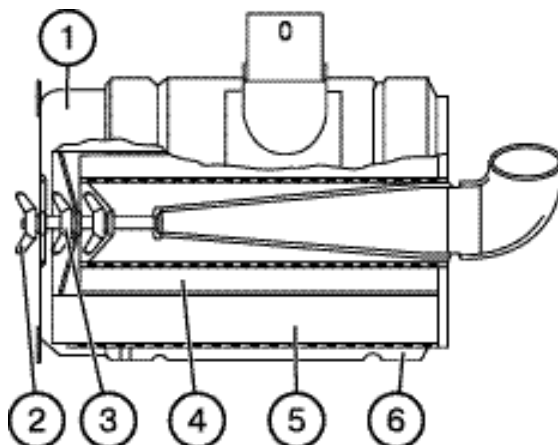

1 – tray; 2 – wided nut; 3 – wided nut of the master filter element; 4 – check filter element; 5 – master filter element; 6 – housing.

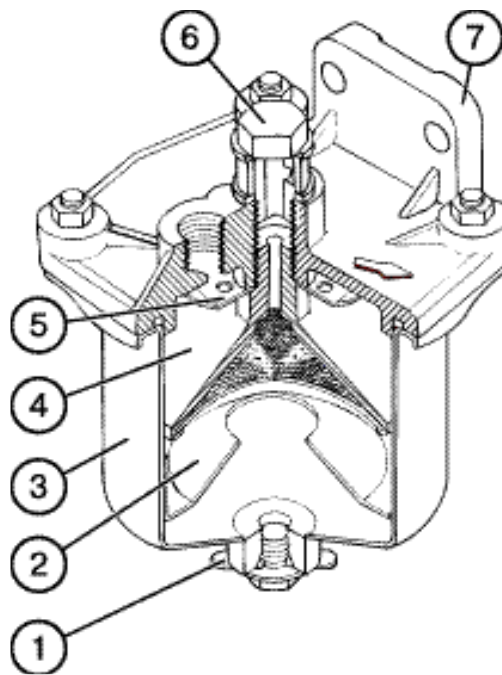

1 – plug; 2 – damper; 3 – shell; 4 – deflector; 5 – diffuser; 6 – bolt of the turntable angle-piece; 7 – filter bowl.

The Fine Fuel Filter (FFF) has two replaceable filter elements, unitized with the engine Д-243. Each filter element is installed in a separate easily dismantlable cartridge of a filter.

The fine fuel filter is intended for multiple usages subject to regular replacement of filter elements and rubber gaskets and observance of the operating instructions.

To bleed air from the engine fuel feed circuit, the filter bowl is provided with a plug (3), refer to Figure below.

The fuel is injected into the cylinders by the closed-type injectors with five-bore nozzles.

NOTE: Starting from the second half-year of 2003, the tractor engines are fitted with fine fuel filters with one filter element fully unitized with an FFF of the Д-243 four-cylinder engines and their modifications. The plug serves for bleeding off air from the engine fuel feed system.

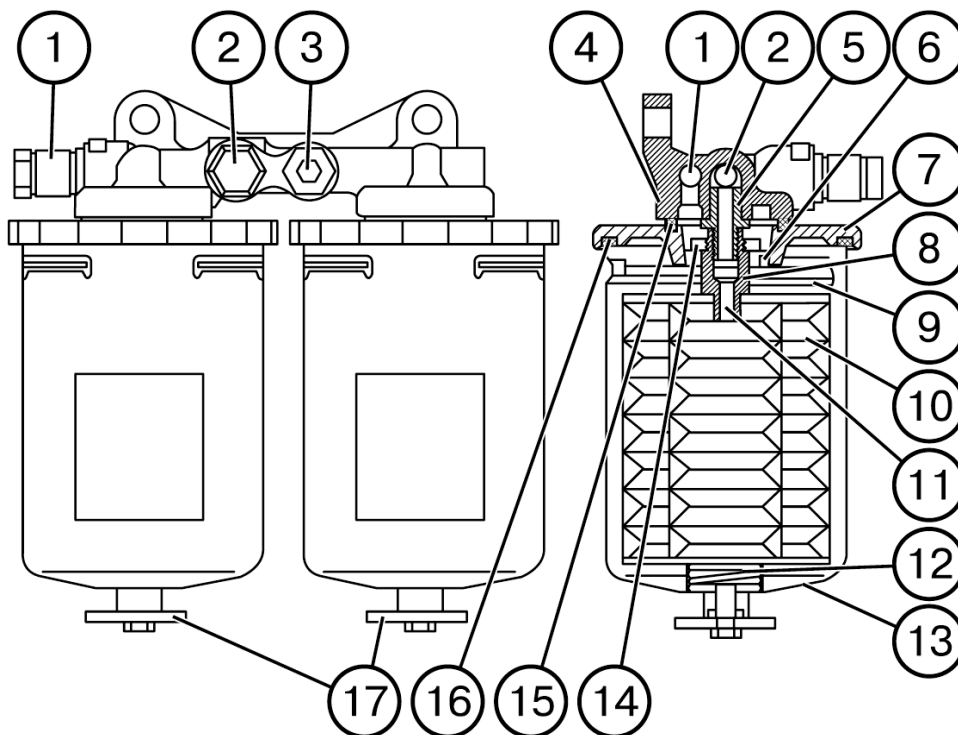

1 – inlet port; 2 – outlet port; 3 – plug for bleeding the air; 4 – filter housing; 5 – fitting union; 6 – inlet opening; 7 – head; 8 – fitting union; 9 – pressing plate; 10 – filter elements; 11 – fuel outlet passage; 12 – spring; 13 – bowl; 14 – nut; 15, 16 – gaskets; 17 – drain plug.

The diesel fuel injection (high-pressure) pump is of in-line six-plunger type providing the metering of fuel by changing the fuel-feed end point. The

pump is provided with a pneumatic anti-smoking adjuster and driven off the crankshaft through valve control gearing.

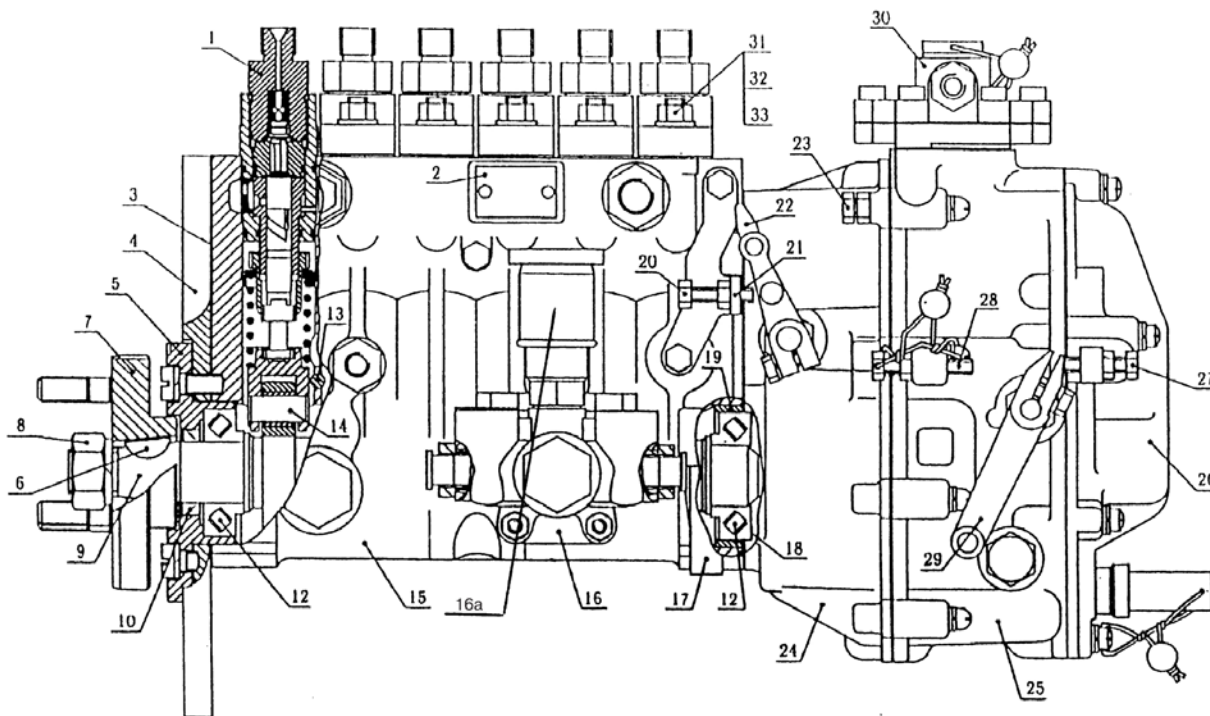

1 – fuel pump section; 2 – nameplate; 3 – flange gasket; 4 – flange; 5 – bearing cap; 6 – Woodruff key; 7 – drive half-coupling; 8 – half-coupling attachment nut; 9 – camshaft; 10 – bearing cap collar; 11 – bearing cap gasket; 12 – bearing; 13 – lifter guiding pin; 14 – lifter; 15 – fuel pump body; 16 – fuel-boosting pump; 16a – hand fuel-lift pump; 17 – FHHP supporting bracket fid; 18 – adjusting shims; 19 – bearing raceway; 20 - bolt; 21 – supporting bracket; 22 – shut-down lever; 23 – bolt; 24 – governor housing; 25 – governor cover; 26 – inspection hatch cover; 27 – minimum rpm adjusting bolt; 28 – maximum rpm adjusting bolt; 29 – control lever; 30 – waste-gate adjusting valve; 31 – stud; 32 – nut; 33 – washer.

The following two levers are installed in the governor housing (24):

- Control lever (29) with a stop for maximum or minimum idling rotational speed;
- Engine stoppage and fuel

emergency shut-off lever (22), which cuts off fuel supply when in the right-most position.

The control lever (29) is connected through a cable with the fuel-feed control pedal and lever. The fuel pump forms an integral unit with a fully-variable all-speed governor and a piston-type fuel-boosting pump.

The Governor comprises the fuel-feed adjusting valve, an automatic mixture enrichment dresser operating at start-up

rpm, and an antismoking pneumatic adjuster which is connected with the engine induction manifold through an air duct.

The **Fuel-Booster Pump** (16) is mounted on the fuel injection pump body and driven by the camshaft eccentric.

For bleeding the air from the feed system, a hand-operated piston-type lift pump is provided, and the plugs serve for bleeding the air from the fuel-pump head and the FFF, respectively.

The fuel supply is controlled by means of the pedal and lever.

The fuel pump parts are lubricated from the engine lubrication system.

Turbocharger

The turbocharger serves for charging air into the engine cylinders using the energy of exhaust gases. It consists of a centrifugal one-stage compressor (6) and a radial centripetal turbine (1).

The turbine wheel (1) is cast of a refractory nickel alloy and welded to the rotor shaft. The compressor wheel (6) is an aluminium alloy casting and is attached on the rotor shaft by means of a special nut (7).

The principle of operation of the turbocharger is as follows. The exhaust gases from the cylinders enter the gas-turbine chamber from the exhaust manifold. Expanding, the gases rotate the turbine wheel together with its shaft, on the other end of which the compressor impeller is fitted.

From the turbine gases are discharged into the atmosphere through the exhaust pipe.

The excess air pressure downstream the compressor under engine design condition should be 0.07...0.10 MPa (0.7...1.0 kgf/cm²).

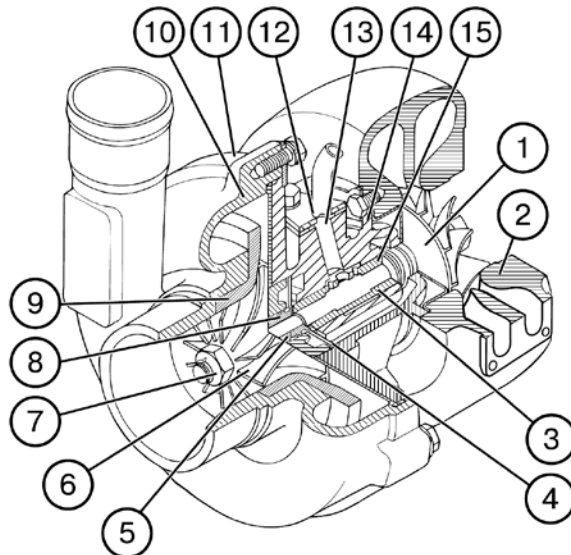

1 – turbine wheel and shaft unit; 2 – turbine housing; 3 – bearing; 4 – oil deflector; 5 – O-ring; 6 – compressor impeller; 7 – special nut; 8 – bushing; 9 – diffuser; 10 – disk; 11 – compressor housing; 12 – lock ring; 13 – retaining holdfast; 14 – intermediate body; 15 – bushing.

The engine lubricating system is combined: some parts are force-lubricated; others are splashed lubricated. The system includes an oil pump, oil filter with a paper filter element, centrifugal oil filter, and an oil-to-water heat exchanger. The lubrication system diagram is shown below.

The Oil Pump (20) is a gear-type, single-stage unit driven from the crankshaft. It contains an overflow, or transfer, valve which opens at a pressure above 0.7...0.75 MPa (7...7.5 kgf/cm²) and passes oil from the discharge chamber into the suction chamber.

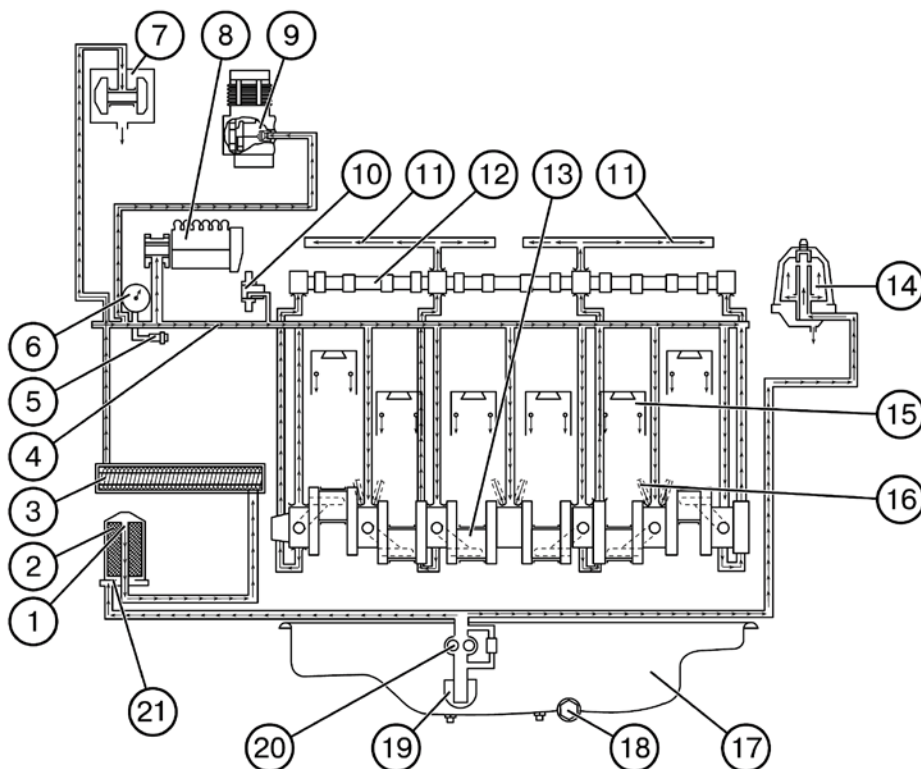

1 – transfer valve; 2 – paper oil filter; 3 – heat-exchanger; 4 – main oil pipeline; 5 – oil pressure warning sensor; 6 – oil pressure gauge; 7 – turbocharger; 8 – fuel pump; 9 – pneumatic compressor; 10 – intermediate gear; 11 – rocker-arm axle oil passage; 12 – distribution camshaft; 13 – crankshaft; 14 – centrifugal oil filter; 15 – piston; 16 – piston cooling jet; 17 – crankcase; 18 – drain plug; 19 – oil pick-up; 20 – oil pump; 21 – relief valve

The oil pump takes oil from the crankcase through the oil pick-up and delivers it to a full-flow oil filter equipped with a paper filter element through passageways in the cylinder block. Some quality of oil enters the centrifugal oil filter to be cleaned and drained back into the crankcase.

The filter element houses a bypass valve (1). The valve opens in case of excessive clogging

of the filter element as well as when a cold engine start-up is attempted, and returns oil into the main pipeline, bypassing the filter element. This valve is not adjustable. Besides, the filter contains a relief valve (21) adjusted to maintain the pressure in the lubrication system within the range 0.28...0.45 MPa (2.8...4.5 kgf/cm²).

When the engine is running, the oil filtered and cooled in the oil-to-fluid heat-exchanger (3) is delivered to all bearings of the crankshaft and camshaft through passageways in the cylinder block. Through the injectors (16) built into the engine block main journals, the oil is fed for cooling the pistons (15). Downstream the heat exchanger (3), oil is passed through separate pipelines for lubricate the turbocharger (7) and the tractor pneumatic system compressor (9).

The Engine Cooling System is of a closed liquid-type with forced circulation of the fluid. The system consists of a cooling jacket, water pump, radiator, fan

with automatically controlled viscous coupling, two thermostats, expansion bottle, connecting hoses, and drain taps.

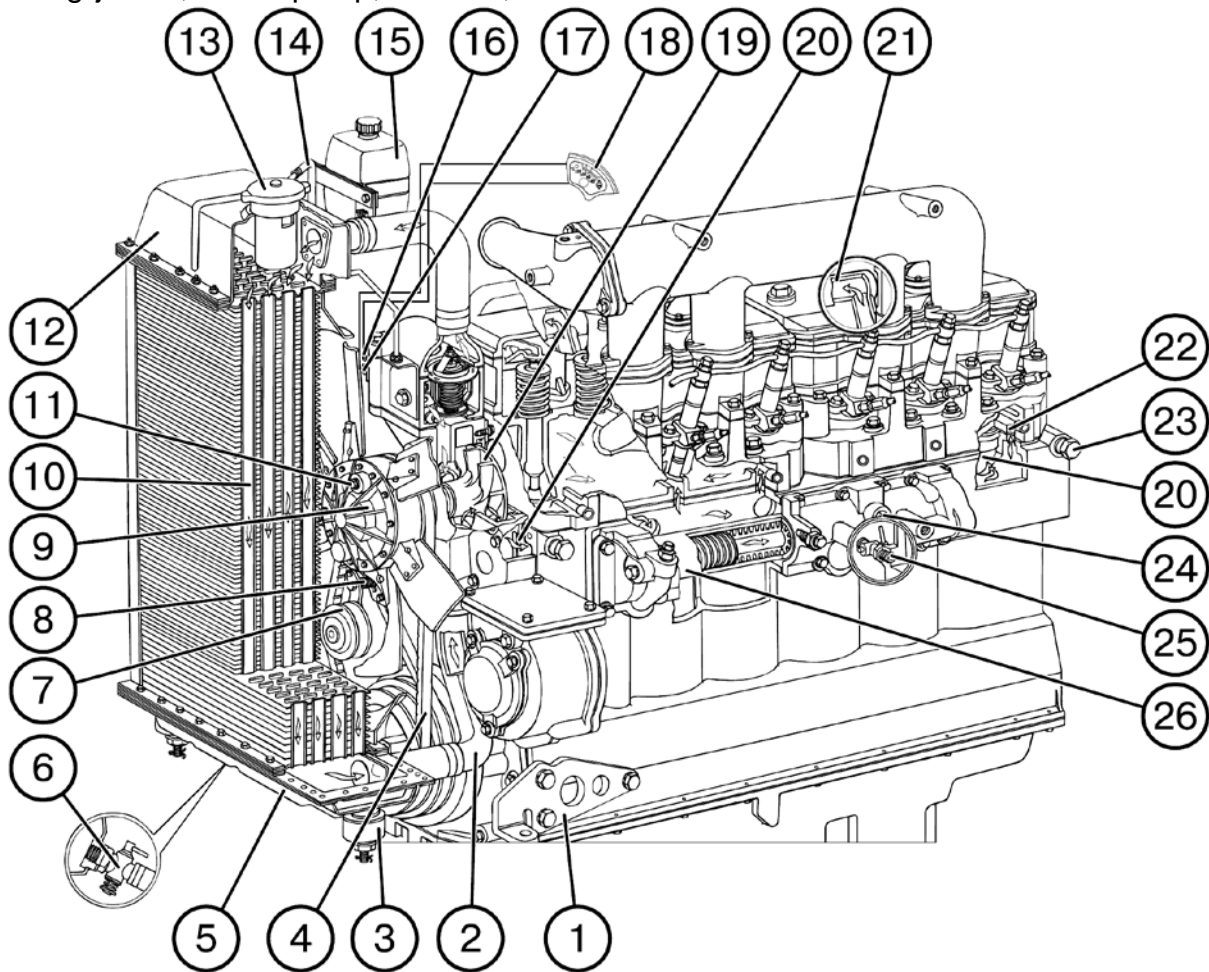

1 – engine attachment bracket; 2 – water pump branch pipe; 3 – water radiator mount rubber damper; 4 – water-pump drive belt; 5 – bottom radiator tank; 6 – water drain tap of the radiator; 7 – water-pump belt tensioner idle pulley; 8 – automatic tensioner spring; 9 – automatically switched fan assembled with the coupling; 10 – water radiator core; 11 – fan forced-engagement mechanism detent; 12 – top radiator tank; 13 – water-radiator filler cap; 14 – air-vapour tube; 15 – expansion bottle; 16 – coolant temperature sensor; 17 – coolant temperature warning sensor; 18 – engine coolant temperature indicator (with a coolant temperature warning lamp); 19 – water-pump fan impeller; 20 – cylinder block water jacket cavity; 21 – water accumulation tube; 22 – passageways directing the coolant jets of the cooling system; 23 – eye-bolt; 24 – plug; 25 – cylinder block fluid drain tap (located on the opposite side of the engine); 26 – oil-to-fluid heat exchanger.

The thermal condition of the engine is regulated by changing the amount of air passing through the cooling system radiator as well as with the help of two thermostats.

The coolant temperature is monitored by means of the remote temperature indicator and audible and light alarms whose

sensors are located in thermostat covers. The normal heat condition of the engine corresponds to coolant temperature of 80...97°C.

The engine lubricating oil is cooled in the oil-to-fluid heat-exchanger built into the engine block. To control the oil pressure, the sensors of the oil pressure gauge

and alarm pressure indicator installed in the heat-exchange branch pipe are used. The normal diesel heat condition as to lubricating oil is within 80...120°C.

The Radiator is of finned tubular type. A steam valve in the radiator filler neck maintains the pressure within the range of 0.045...0.05 MPa while the air valve maintains the vacuum within the range of 0.01...0.08 MPa.

The Fan runs in two operating modes:

- automatic;
- forced.

The **automatic mode** is provided by a viscous friction coupling as follows: at the coolant temperature below 80°C the return spring (7) retains the valve (10) in the closed state; viscous fluid flows into the coupling reserve cavity; the driving (11) and driven (13) disks are rotating with a gap in-between them and, thus, ensure the minimum rotational speed of the fan (in this case, the fan rotational speed shall not exceed 1,500 rpm).

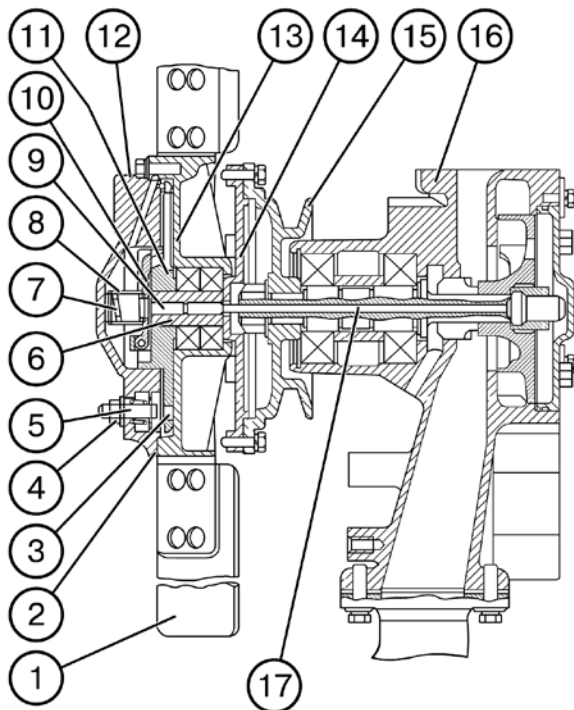

- 1 – fan blade; 2 – driven plate; 3 – opening for detent; 4 – detent nut; 5 – detent; 6 – stem; 7 – return spring; 8 – spring holder; 9 – follower; 10 – valve; 11 – driving plate; 12 – clutch; 13 – driven plate; 14 – drive shaft; 15 – water-pump pulley; 16 – water pump; 17 – release rod

Should the engine coolant temperature exceeds 80°C, the thermosensitive element will open the valve (10) acting through rod (17) and piston lifter (9) against the force of the return spring (7). The viscous fluid flows over into the head cavity and fills in the gap between the driving and driven plates due to that the disks are engaged, and the fan is turned on in its normal operating duty.

ATTENTION! With the cooling system compressor running, the **forced mode** of fan operation should be chosen.

To switch the fan over to the **forced** (continuous) operation mode, proceed as follows:

- turn out the nut (4) of the detent (5) by 4...5 revolutions (about 5 mm);
- turn the fan by hand, so that the detent (5) enters hole (3) in the driving plate (11).

If necessary, press the detent (5) by hand to lock the driving and driven plates.

Electric Equipment and Starting System

The electric equipment aggregates installed on the engine, include the alternator with the capacity of 1150 W (for the engine Д-260.1) and 2000 W (for the engine Д-260.1S2) and voltage of 14 V.

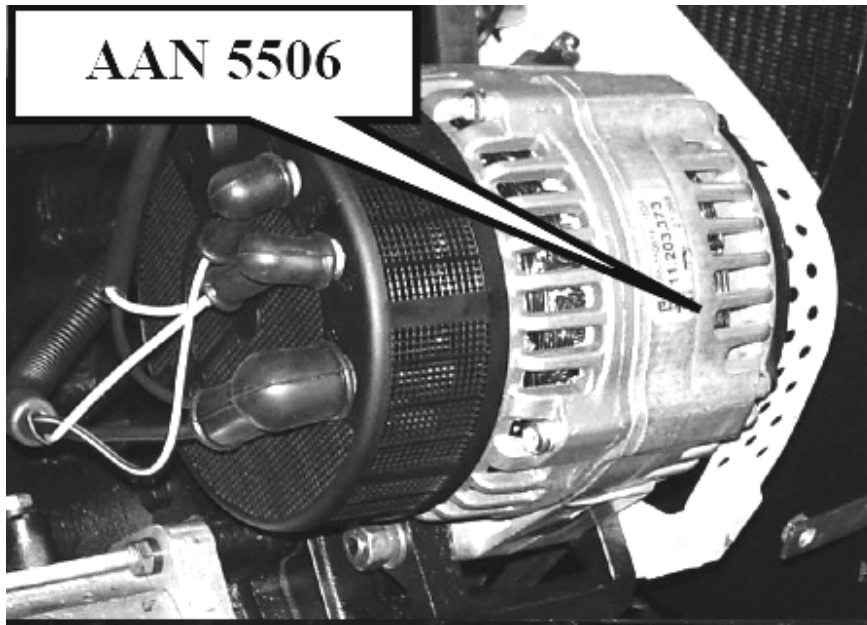

AAN 5506 alternator manufactured by the Iskra company. This type belongs to up-to-date brush-type compact generators with increased capacity.

The main features of the alternator are:

- Existence of the rotating field windings and, respectively, brushes that makes it possible to increase the alternator output power;

- Necessity of current inflow into the field winding prior to starting the engine (as a rule, the brush-type alternators have no self-excitation feature).

For current inflow into the alternator field winding, there is an additional resistor on the tractor (in the relay box on the engine).

Prior to starting the engine, the voltage from the starter and instrumentation is applied to the terminal “Д” of the alternator through the resistor and then to the field winding (these elements are connected in parallel). When it will be done,

the voltage at the terminal “Д” will be approximately 0.8-0.9 V. After starting the engine, the field winding starts rotating and the voltage regulator comes into operation to provide the output voltage of the alternator within the range 13.8-15 V.

ATTENTION! To avoid the damage of the regulator relay, it is prohibited to check the serviceability of the alternator by removing the SB terminals or setting the battery disconnect switch to the OFF position when the diesel is running!

The **Engine Starting Device** is an electric starter with the voltage of 24 V and capacity of 5.5 kW.

The starter is a DC series-excitation electric motor. The starter is energized remotely, by means of an electromagnetic relay and starter switch. To facilitate the starting of the engine at low ambient temperatures, the remotely-controlled glow plugs installed in the cylinder heads are used.

Pneumatic Compressor

To ensure reliable operation of the tractor pneumatic system and tyre inflation, the engine is equipped with a single-piston, single-stage compressor. When performing the agricultural works which do not require the energy of compressed air, the compressor shall be turned OFF.

The compressor is mounted on the fuel distribution unit cover flange and driven from the fuel-pump drive gear. The

compressor is air-cooled. When the compressor is running, the fan shall be switched to the forced mode.

The compressor delivery is 180 l/min at a backpressure of 0.6 MPa (6 kgf/cm²) and the rated rotational speed.

NOTE: With the compressor running, the engine fan shall be switched to the forced mode.

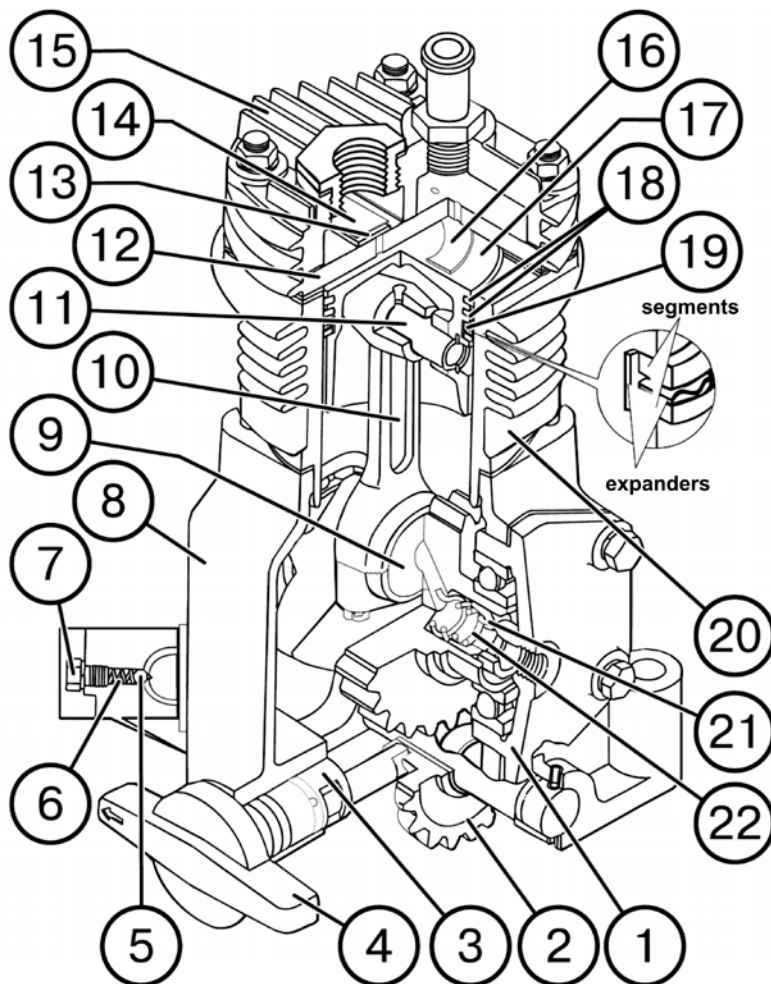

1 – ball-bearing body; 2 – compressor drive intermediate gear; 3 – shaft with a compressor engagement eccentrically-located pin; 4 – lever for engaging the compressor; 5 – shaft lock; 6 – spring; 7 – shaft lock bolt; 8 – compressor crankcase; 9 – crankshaft with a drive pinion; 10 – connecting rod; 11 – piston pin; 12 – plate; 13 – pressure valve; 14 – restraint; 15 – cylinder head; 16 – suction valve; 17 – piston; 18 – compression ring; 19 – segments, expanders (oil scraper piston ring); 20 – cylinder; 21 – seal; 22 – spring.

CLUTCH

Clutch Mechanism

A dry double-plate type, constantly engaged clutch is installed on the engine flywheel (1).

A dry double-plate type, constantly engaged clutch is installed on the engine flywheel (1).

The flywheel (1), the pressure plate (3) and the intermediate plate (2) with three prongs on its surface, which enter into special slots on the flywheel (1), constitute the driving section of the clutch. The driven section of the clutch consists of two driven plates (24) fitted with vibration dampers (9) installed on the power-transmission shaft (7). A necessary pressing force of friction surfaces of the clutch driving and driven sections is developed by nine external and internal springs (22). A resilient element is installed between the floating bushing (8), coupled with the driving shaft (4), and the clutch bearing plate (12).

The intermediate plate (2) is fitted with leverage mechanisms (11) which operate to place the plate (2) equidistant from the friction surfaces of the flywheel (1) and the pressure plate (3), when the clutch is disengaged. The forks (13) fastened on the bearing disk by means of the adjusting nuts (15) locked by the washers (14) serve as supporting points for the clutch release levers.

The engagement and disengagement of the clutch are achieved with the help of the clutch release shifter (17) assembled with the throw-out bearing (16) which can slide along the support (18). The shifter fork (19) together with spindle (20) is connected with the clutch pedal through a hydrostatic actuator.

The throw-out bearing (16) is lubricated through a grease nipple screwed in into the shifter shank.

The grease nipple is on the left-hand side of the clutch housing. It is necessary to unscrew the plug (A) to gain access thereto.

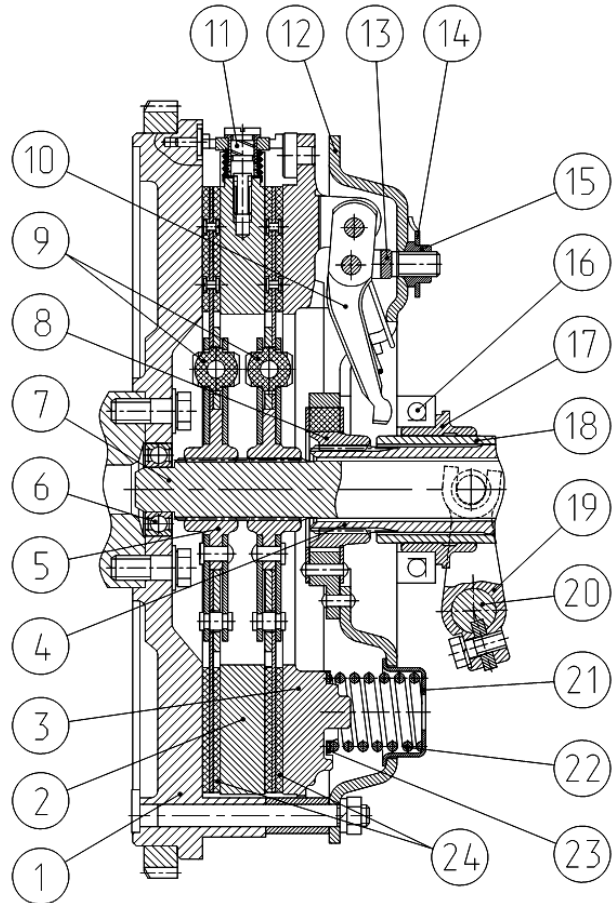

1 – flywheel; 2 – intermediate plate; 3 – pressure plate; 4 – PTO driving shaft; 5 – hub; 6 – bearing; 7 – transmission shaft; 8 – floating bushing; 9 – vibration damper; 10 – clutch release lever; 11 – leverage mechanism; 12 – bearing plate or clutch cover; 13 – fork; 14 – washer; 15 – nut; 16 – bearing; 17 – clutch release shifter; 18 – clutch release shifter support; 19 – clutch release fork; 20 – control spindle; 21 – shell cup; 22 – pressure springs; 23 – separating washer; 24 – driven plates.

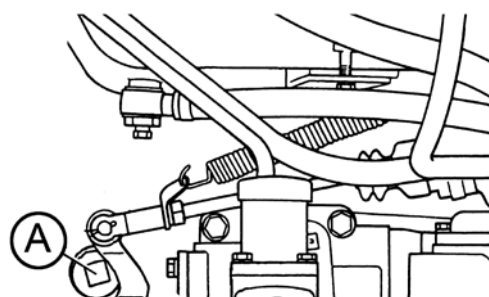

Assembling, disassembling and adjustment of the clutch

Procedure of dismantling the clutch from the engine:

1. Set three auxiliary bolts (M12x40) by turning them into the pressure plate (4) through the auxiliary holes of the bearing plate (7).
2. Turn out the nuts fastening the bearing disk to the flywheel and remove the clutch disks (bearing disk (7) complete with the pressure one (4)).
3. Remove the first driven plate (2).
4. Remove the intermediate disk (3).
5. Remove the second driven plate (2).

Disassembling the clutch disks (basket)

The disassembling of the clutch disks is described in the Manual for Disassembling and Reassembling.

Procedure of re-installation of the clutch onto the engine:

1. Set the splined arbour into the flywheel bearing.
2. Mount the first driven plate (2) onto the arbour with the long end of the hub directed towards the flywheel (1).
3. Mount the intermediate disk (3) into the flywheel slots.
4. Mount the second driven plate (2) onto the arbour with the short end of the hub directed towards the flywheel.
5. Mount the clutch disks (bearing disk (7) complete with the pressure one (4)) on the flywheel pins with bushes (14), fasten them with nuts and turn out the auxiliary bolts.

6. Adjust the position of the release levers (6).

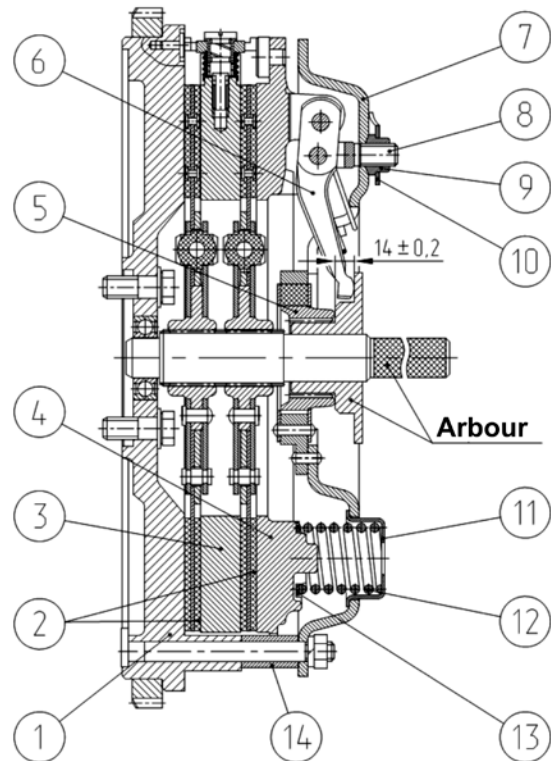

Adjustment of the position of the release levers

1. Adjust the position of the release levers to the distance of 14 ± 0.5 from the bearing surfaces of the levers to the bearing disk hub end face by turning the adjusting nuts (9) in or out. The difference in the size for individual levers shall be not more than 0.3 mm.
2. After adjustment of the levers, mount the locking plates (10).
3. Remove the arbour.

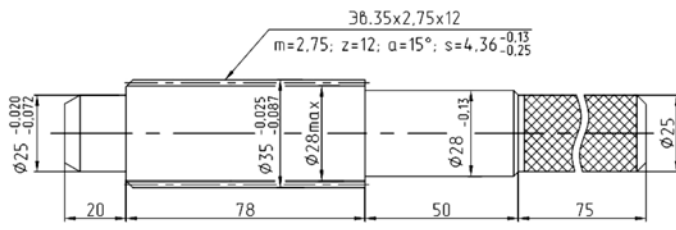

Auxiliary arbour

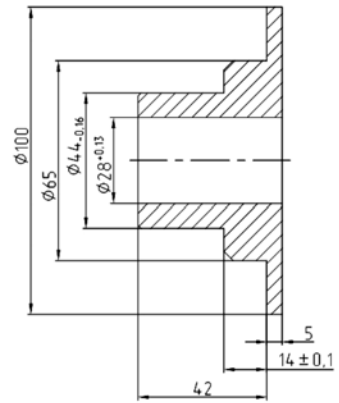

Clutch Housing (for the GB 16F+8R)

The **clutch housing** accommodates the drives of the independent PTO, HLL pump and a pump of the transmission hydraulic system.

The driving shaft (2, 9) of the independent PTO drive supported in bearings (5, 6) has two ring gears. A pinion (16) of the independent PTO drive is in constant mesh with the smaller ring gear, while a gear (20) of the pump of the transmission

hydraulic system and that of the HLL is in mesh with the other ring gear.

The pump of the transmission hydraulic system is driven from the driving shaft (2, 9) through gears (20, 26, 25).

With the clutch engaged, the torque from the clutch actuator plates is transmitted to the gearbox primary shaft through the shaft (1) and the bushing (8).

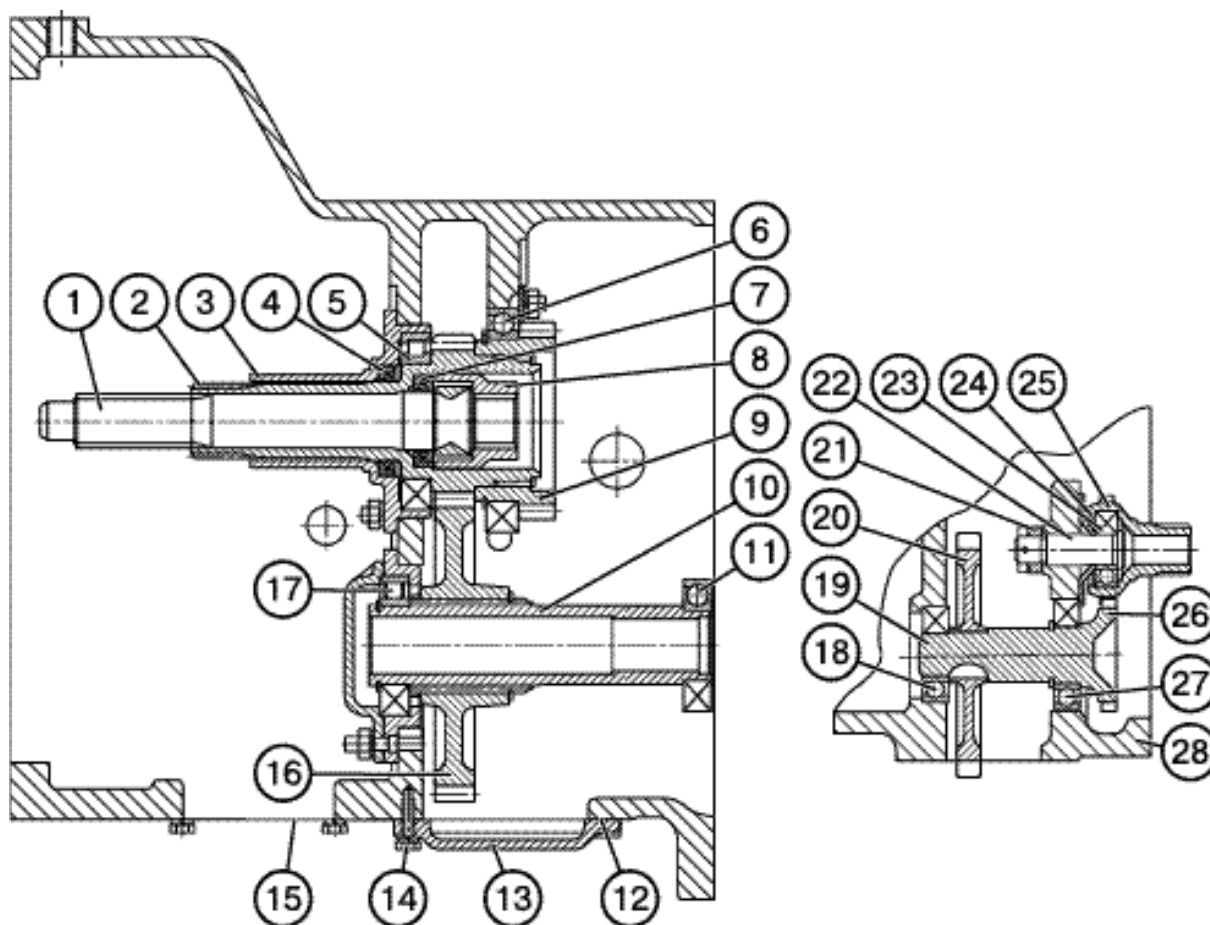

1 – force-transmission shaft; 2, 9 – PTO driving shaft; 3 – clutch release shifter support; 4, 7 – collars; 5, 6, 17, 18, 23, 27 – bearings; 8 – splined bushing; 10 – PTO driven shaft; 11 – bearing; 12 – packing liner; 13, 15 – covers; 14 – bolt; 19, 26 – pinion-shaft; 20 – HLL and transmission pumps drive gear; 21 – spindle; 22 – axle; 24 – check ring; 25 – pinion-shaft; 28 – housing

Clutch Housing (for the GB 24F+12R)

The clutch housing (30) accommodates the driving and driven shafts with the pinions fitted on them and drives of the oil pumps of the HLL and transmission hydraulic system. The driving shaft (4) is supported in two bearing assemblies. The shaft has a ring gear and splines, on which the pinion (5) is seated. The pinion (5) causes the rotation of the gear (19) of the driven shaft of the independent PTO drive (18) and gear (8) for driving the oil pumps.

The power shaft (1) is passed inside the shaft (4) and transmits the torque from the clutch to the gearbox primary shaft through the splined bushing (6). The

driven shaft (18) is supported in two bearings (17, 27) in the housings of the clutch and gearbox. The driven gears (19) and (24) of the two-speed drive of the independent PTO are fitted on the shaft in the needle bearings (25). The fixed connection of the gears (19, 24) with the shaft is achieved by means of the toothed coupling (23), with is moved by means of the fork (20) and shaft (21). The HLL is driven by means of the pinion (5) and gear (8) and the pump of the transmission hydraulic system is driven through the pinion (5), gear (8) and shafts (15) and (12).

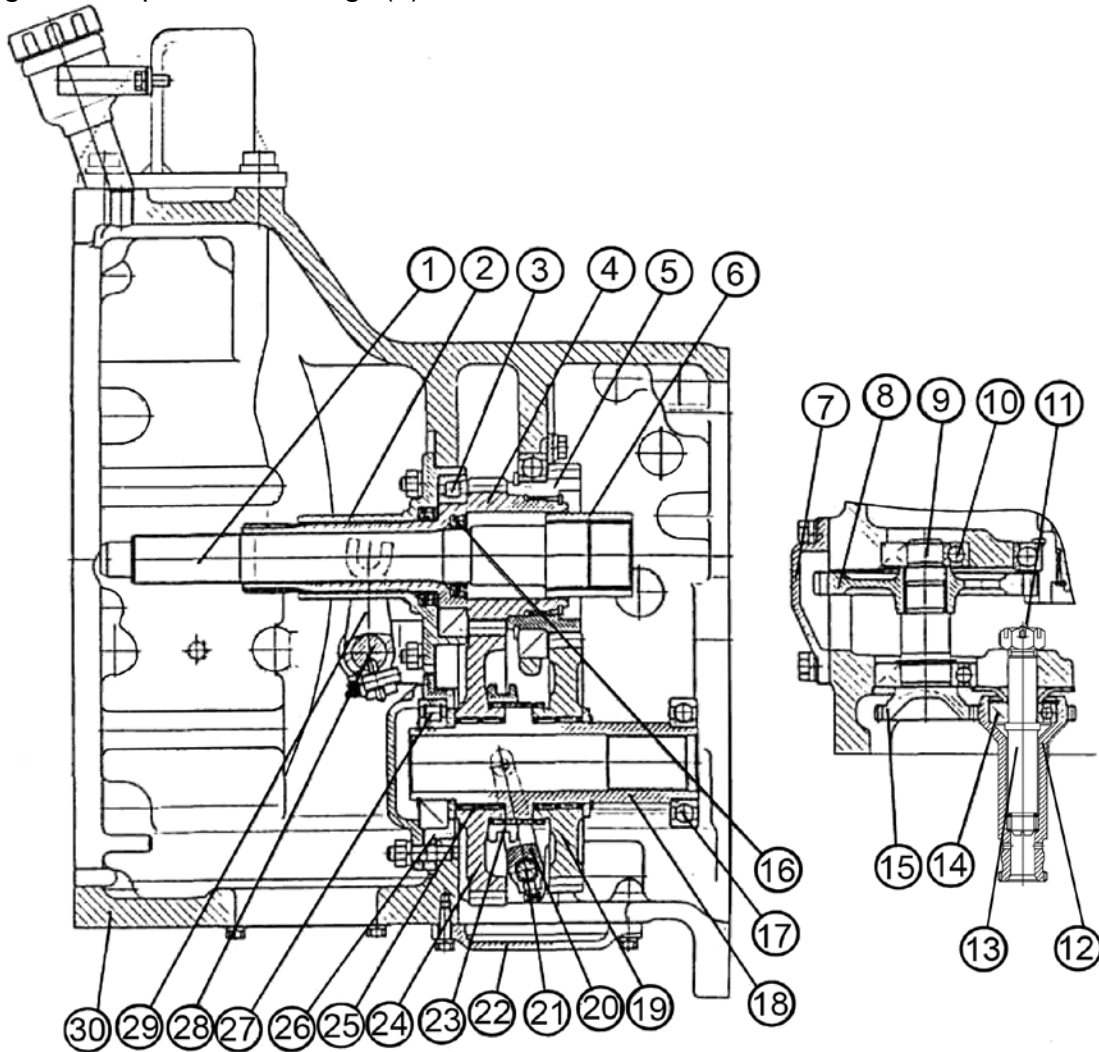

1 – power shaft; 2 – bracket, 3,10, 14, 17, 25, 27 – bearings; 4 – driving shaft; 5 – pinion; 6 – splined bushing; 7 – cover; 8 – HLL and transmission pumps drive gear; 9, 15 – pinion shaft; 11 – nut; 12 -pinion shaft; 13 – axle; 16 – collar; 18 – driven shaft; 19 – gear; 20 – fork; 21 – roller; 22 – cover; 23 – toothed coupling; 24 – gear; 26 – spindle; 28 – roller; 29 – fork; 30 – housing.

Clutch actuator

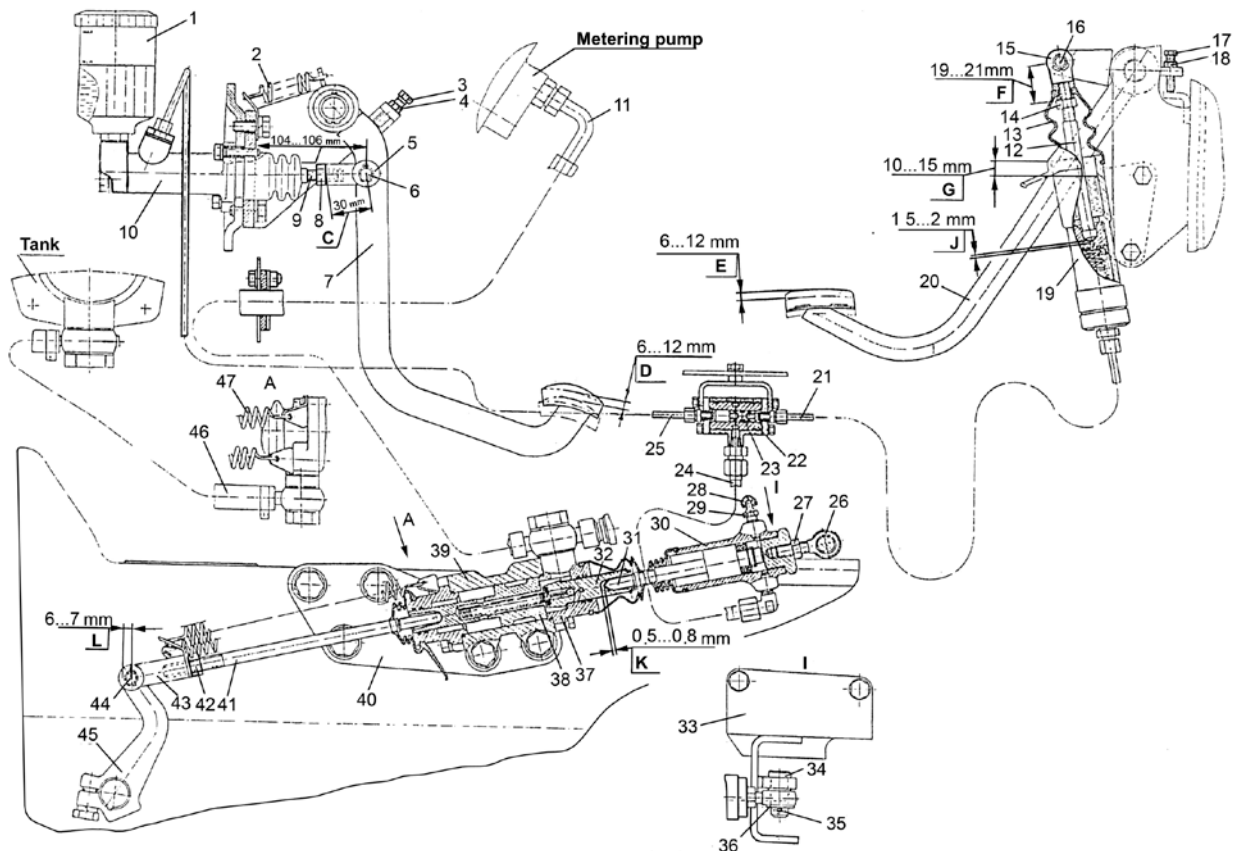

1 – reservoir; 2 – spring; 3, 17 – bolt; 4, 8, 14, 18, 27, 42 – nut; 5, 15, 43 – fork; 6, 16, 34, 44 – pin; 7 – clutch pedal for forward motion; 9, 12, 31, 32 – piston lifter; 10 – master cylinder for forward motion; 11 – oil pipeline; 13 – boot; 19 – master cylinder for reverse; 20 – clutch pedal for reverse; 21, 25 – tubing; 22 – tap; 23 – piston; 24 – flexible hose; 26 – support; 28 – protective cap; 29 – overflow valve; 30 – master cylinder; 33, 40 – bracket; 35 – cotter pin; 36 – washer; 37 – cover; 38 – piston; 39 – hydraulic booster; 41 – rod; 45 – lever; 46 – hose; 47 – release spring.

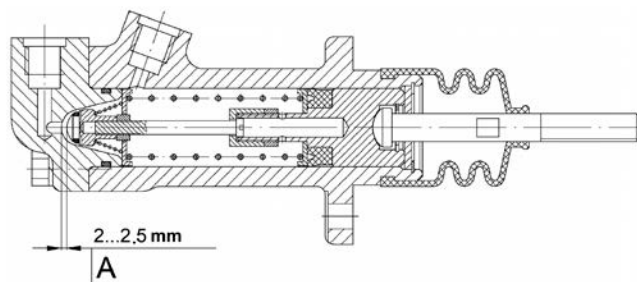
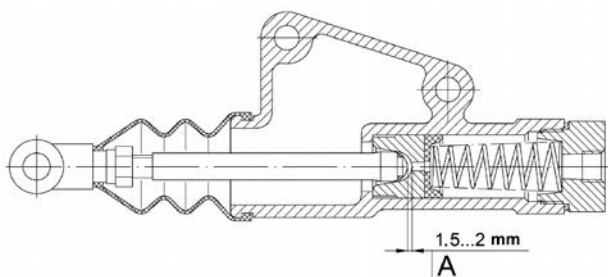

Master cylinder 2022-1602810

Master cylinder 1221B-1602610

The clutch actuator is intended for controlling the clutch in both forward and reverse motion of the tractor.

The clutch actuator is of hydrostatic type with overhang pedals and hydraulic booster.

The actuator consists of the master cylinders (10) (for forward motion) and (19) (in the reverse mode), overhang pedals (7) (for forward motion) and (20) (in the reverse mode), tap (22) (for automatic switching from the forward motion to the reverse mode or vice versa), service cylinder (30), hydraulic booster (39), lever (45), reservoir (1), connecting tubings and oil pipes.

The flow-type hydraulic booster (39) is intended for reducing the force to be applied to the pedals (7) and (20) for disengaging the clutch. It is connected with the oil discharge flow of the HPS metering pump via oil pipe (11), and with the drain into the HPS reservoir via hose (46).

On stepping on the pedal (7) in the forward motion mode, the brake fluid is passed from the master cylinder (10) through the tubing (25) to the tap (22). In the tap (22), the piston moves to the rightmost position and closes the input of the tubing (21). Then the brake fluid is passed through the flexible hose (24) to the working cylinder (30) while moving the piston lifter (31). The piston lifter (31) acts upon the piston lifter (32) of the hydraulic booster (39) that causes the operation of the hydraulic booster and advancement of the piston and rod (41) rotating the lever (45) connected with the clutch release shifter that in turn causes the disengagement between the engine and the transmission.

On stepping on the pedal (2) in the reverse mode, the brake fluid is passed from the master cylinder (19) through the tubing (21) to the tap (22). In the tap (22), the piston moves to the leftmost position and closes the inlet of the tubing (25). Then the brake fluid is passed through the flexible hose (24) to the working cylinder (30) and acts as described above.

The "Neva-M" brake fluid, TY 2451-053-36732629-2003 is used as a working fluid in the clutch actuator system.

Clutch Control Adjustment

1. Adjusting the clearance between the piston and the piston lifter (9) of the master cylinder (10) (for forward motion):

- Set the initial position of the pedal (7) by means of the adjusting bolt (3) and fork (5) having kept the dimension "B";

- Adjust the clearance between the piston lifter (9) and the piston of the master cylinder (10) by means of the fork (5). When doing this, the travel of the pedal (7) from the initial position to the moment of contact of the piston lifter (9) with the piston as measured at the centre of the pedal boot shall correspond to the dimension "G";

- Tighten the nuts (4, 8) and fix the pin (6) with a cotter pin;

2. Adjusting the clearance "J" between the piston and the piston lifter (12) of the master cylinder (19) (for working in the reverse mode):

- Remove the boot (13);

- Unlock the piston lifter (12);

- Screw the piston lifter (12) of the master cylinder (19) into the fork (15) having kept the dimension "F";

- Tighten the nut (14) and refit the boot (13);

- Adjust the free travel of the pedal (20) as measured at the centre of the boot to the dimension "E" by turning the bolt (17) in and out for ensuring the clearance between the piston lifter (12) and the piston of the master cylinder (19);

- tighten the locknut (18);

3. Adjusting the clearance "K" between the piston lifter (31) of the service cylinder

(30) and piston lifter (32) of the hydraulic booster (39):

- Dismantle the master cylinder (30) from the bracket (33) having removed the pin (34);

- Set the piston lifter (31) in the cylinder (30) to the rightmost position until it rests against the cover;

- Move the cylinder (30) until it contacts the piston lifter (32) of the hydraulic booster (39) without effort and align the holes of the support (26) with those of the bracket (33) by turning the support (26) in or out; then screw the support in by 1/2 revolutions and refit the pin (34);

- Tighten the locknut (27) and fix the pin (34) with a cotter pin;

4. Adjusting the free travel of the clutch release shifter:

- Remove the two release springs (47);

- Disconnect the rod (41) from the lever (45) having removed the pin (44);

- Unlock the fork (43);

- Move the rod (41) to the right until the piston (38) of the hydraulic booster (39) rests against the cover (37), turn the lever (45) counter-clockwise until the release bearing rests against the release levers and align the holes of the lever with those of the fork by rotating the fork (43); then turn the fork in by 5...5.5 revolutions (dimension "L") and connect the same with the lever by means of the pin (44);

- tighten the nut (42), fix the pin (44) with a cotter pin and refit the two release springs (47).

Bleed air from the hydraulic clutch control system.

Bleeding the air from the hydraulic clutch control system

Prior to bleeding, fill the reservoir (1) of the master cylinder for forward motion (10) and the equalizing chamber of the master cylinder for reverse (19) with brake fluid.

1. Bleed air from the hydraulic system in the forward motion. To do this:

- Fill the reservoir (1) with brake fluid to the mark "MAX";

- Remove the protective cap (28) from the cylinder (30) and fit a rubber hose onto the head of the bypass valve (29). Dip another end of the rubber hose into a vessel with brake fluid;

- Step on the clutch pedal several times; while holding down the pedal, turn out the bypass valve (29) by quarter of revolution to release the excess fluid brake with air bubbles into the vessel with brake fluid;

- Turn in the bypass valve (29) and release the clutch pedal;

- Bleed air from the system until the air bubbles in the released brake fluid disappear completely;

- Remove the hose and refit the protective cap (28);

- Check the brake fluid level in the reservoir (1) and add it as necessary.

2. Bleed air from the hydraulic system in the reverse mode. To do this:

- Remove the boot (13) of the master cylinder (19);

- Check the brake fluid level in the equalizing chamber of the master cylinder (19), which shall not be below dimension "G" from the top edge of the equalizing chamber;

- The procedure of bleeding air from the hydraulic system is similar to that for the forward motion.

3. Check the bleeding of air from the hydraulic system according to item 1.

ATTENTION! When bleeding air from the hydraulic system:

- for forward motion: maintain the brake fluid level in the tank (1) between the marks "MIN" and "MAX";

- - for reverse mode: maintain the brake fluid level in the equalizing chamber of the master cylinder (19)

to be not below the dimension G from the top edge of the equalizing chamber.

When performing the adjustment, ensure the coaxiality of the hydraulic booster (39) and service cylinder (30) by shifting the bolts of the brackets (33), (40) before tightening them.

If the adjustment is performed correctly, the pedal (7) being released shall be positioned according to the dimension "B". When the pedal (7) is completely depressed, the piston lifter (9) shall move to the value "C" and the

lever (45) on the radius 105 mm shall move to 24...26 mm.

After checking the adjustments of the clutch control, the smoothness of the clutch disengagement should be checked. To do this:

- Start the engine and set its rotational speed to 1400 ± 100 rpm;
- Tighten the parking brake;
- Step on the clutch pedals as far as they will go and shift in the GB gears after at least 5 s. The shifting of the gears shall be smooth, without foreign noises. If not so, check the adjustments once again.

GEARBOX

Gearbox (16F+8R)

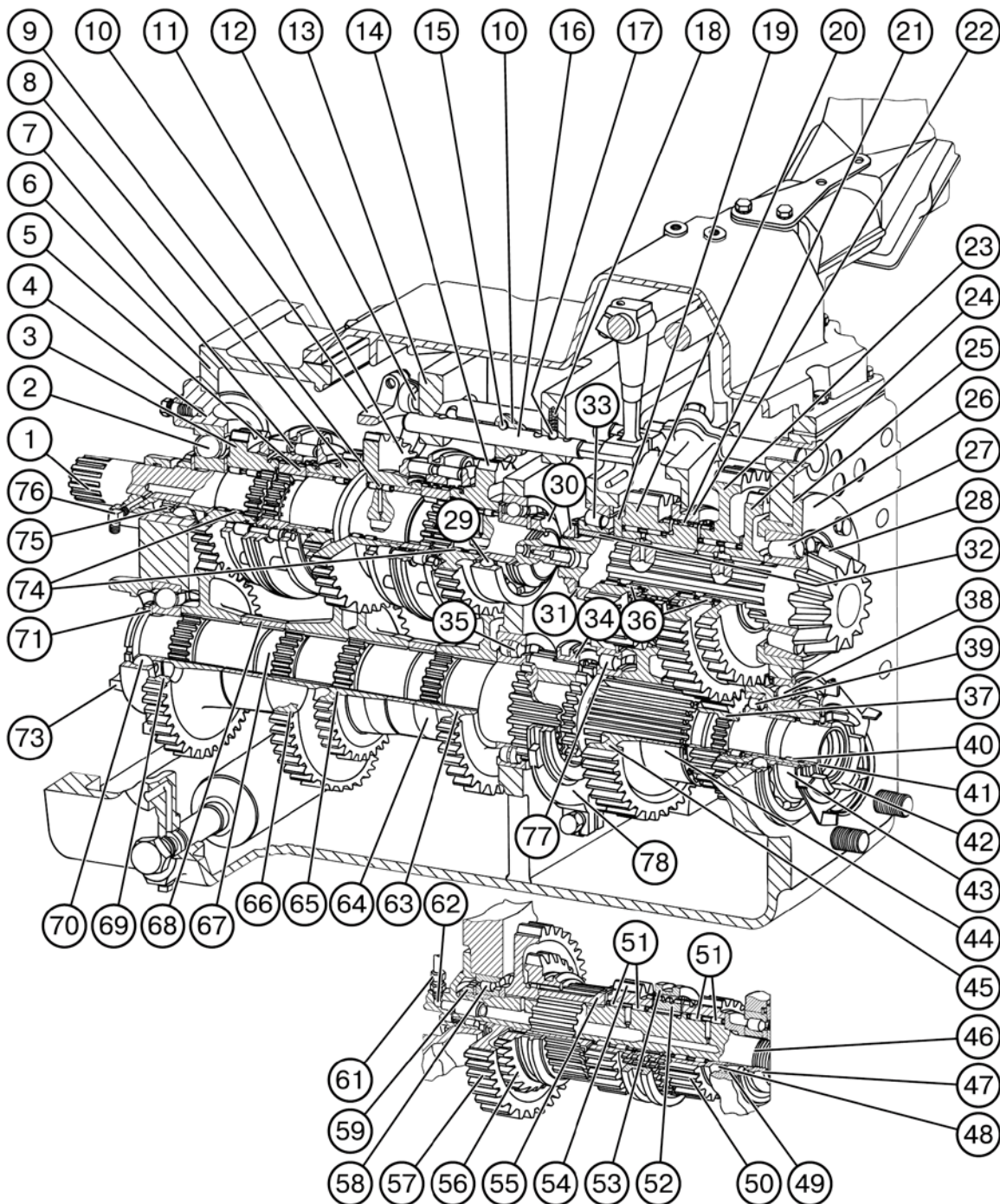

1 – primary shaft; 2, 29, 33, 27, 38, 39, 40, 49, 58, 35, 70, 77 – bearings; 3, 8, 11, 14, 20, 23, 24, 37, 45, 50, 54, 56, 57, 63, 65, 66, 69 – pinions; 4, 26, 62, 73 – sleeves; 5, 44, 48, 55, 64, 68, 19, 32, 52 – bushings; 6 – housing; 7 – synchronizer; 9, 36, 51, 74 – needle bearings; 10 – fork; 12, 16 – dogs; 13 – fork body; 15 – bolt; 17 – ball; 18 – spring; 21 – semi-coupling; 22, 53, 34 – toothed couplings; 25, 31 – adjusting shims; 28 – secondary shaft; 30, 47, 59, 71, 75 – nuts; 41 – gear-cluster shaft; 42 – synchronous PTO pinion; 43 – check ring; 46 – reduced gear shaft; 61 – pipeline; 67 – intermediate shaft; 76 – lubricant feed bush; 78 – fork.

The gearbox is a mechanical fixed-ratio constant-mesh transmission, with 4 forward ranges and 2 backward ranges, with intra-range shift of gears by means of synchronizers. It provides 16 forward speeds and 8 reverse speeds as well as driving of the front drive axle and the synchronous PTO.

Gearbox Structure

The gearbox consists of a drive gear assembly, shaft of reduced speeds and reverse, gear cluster, secondary shaft, control mechanism, hydraulic system, and gearbox housing.

The drive gear assembly consists of a primary shaft (1) with free-installed pinions (3, 8, 11, 14) supported in bearings (9) and (74). Two bushings (5) are splined on the shaft. The bushings carry cone synchronizers (7). The shaft is supported in bearings (2) and (29).

The driven gears (63), (65), (66), (69) are fitted on the intermediate shaft (67) installed in the housing in two bearings (35) and (70) with a slight pre-load.

A pack of gears in assembly with bearings is tightened up on the shaft with a nut (71). The shaft of reduced gears and reverse is installed in the gearbox housing supported in the bearings (49) and (58). The same shaft carries the gear (54) of the first and second ranges and the gear (50) is the reverse one. A bushing (55) with internal and external splines and a creeper pinion (56) installed thereon, sits on the shaft splines. A driven gear (57) is installed on the shaft through a bronze bushing. If a supercharger is not supplied, the gear (57) is connected to the shaft through splines of the gear (56) fixed in this position by means of a check ring on the bushing (55).

The drillings, axial and radial, are made in the shaft for feeding the lubricant to bearings (51) and gear (57) bushing.

The pinions (37) and (44) are installed on the splines of the gear-cluster shaft (41).

This shaft is supported in the bearings (77), (39) and (40). The back mount of the shaft is located in the gear (42) hub of the synchronous PTO drive, in two roller bearings (39) and (40). The gear (42) is supported in the housing in a bearing (38).

The secondary shaft (28) made as an integral part with the driving bevel gear is supported in the housing in tapered bearings (27) and (33).

The driving pinion (24) of the front drive axle is fixedly fitted on the shaft with a driven gear (23) supported in bearing (36) on the pinion hub, semi-coupling (21) and bushing (19) with a driven gear (20) installed thereon. The bushing (19) with a bearing pressed on it is held from pivoting by a stop. The pack of parts on the shaft is tightened up with the nut (30). The axial and radial drillings in the shaft are intended for lubricating the bearings (36) and (27).

Gearbox Control Mechanism

The mechanism of gearbox control consists of a gearshift mechanism, together with synchronizers, and a range-selection mechanism. The gearshift mechanism is mounted in the cover (9) and in the fork box (13) (see Figure "Gearbox (16F+8R)"). The cover (9) houses the fork (16a), lever (11a), dog (19) and lever (8a); the latter is fixed on the dog (19) by means of bolt and key. The fork box (13) (see Figure "Gearbox (16F+8R)") houses the dogs (12, 16) with the forks (10) fixed thereto. The locking balls (17) are provided for preventing the simultaneous engagement of two ranges. The range selection mechanism consists of a fork (16), lever (11), dog (20) and levers (8), installed in the gearbox cover (9) as well as other parts installed in the gearbox housing. The toothed couplings (22, 53, 34) (see Figure "Gearbox

(16F+8R)") are displaced by forks fixed on dogs (fork (78), other parts are not shown). The toothed couplings (22, 53, 34) (see Figure "Gearbox (16F+8R)") are locked in the neutral and engaged positions by means of the parts (6, 7a, 11). The locking balls (6) (see Figure "Engine Start Interlock") are installed in the holes in the gearbox housing for preventing the simultaneous engagement of the toothed couplings (34) and (53) (see Figure "Gearbox (16F+8R)").

Attention! To throw in gear, shift the shifter lever smoothly (without sharp jerks) in accordance with the shift pattern diagram; then keep the lever under slight pressure until the gear is engaged in full.

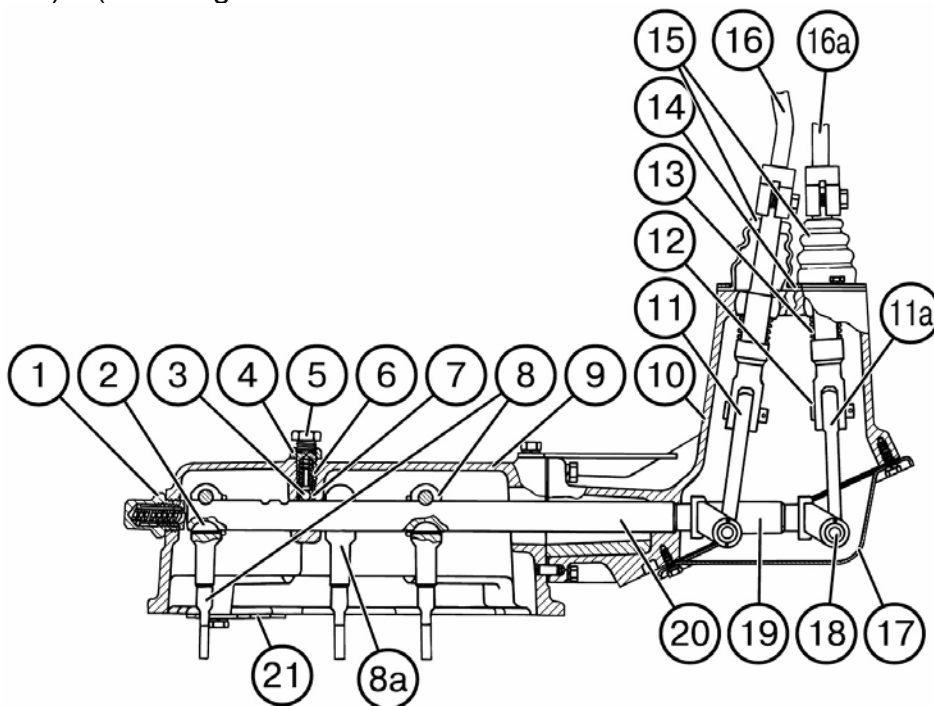

1 – limiter; 2 – key; 3 – ball; 4 – nut; 5 – bolt; 6 – spring; 7 – bushing; 8, 8a – lever; 9 – cover; 10 – housing; 11, 11a – lever; 12 – pin; 13 – spring; 14 – sphere; 15 – boot; 16, 16a – fork; 17 – cover; 18 – pin; 19, 20 – dogs; 21 – link.

Engine Start Interlock

The tractor is provided with a special interlocking device for preventing the engine from starting, when a gear is engaged.

The interlocking device consists of a switch (8) installed in the gearbox housing on the left-hand side, locking balls (6) and fingers (7, 7a).

With the range engaged, the interlock mechanism opens the switch contacts

and breaks the circuit of the intermediate starter relay (1) and that of the starter pull-in relay (5).

The adjusting shims (9) are provided for adjusting the switch opening.

Prior to starting the engine, set the range selector lever of the gearbox to its neutral position!

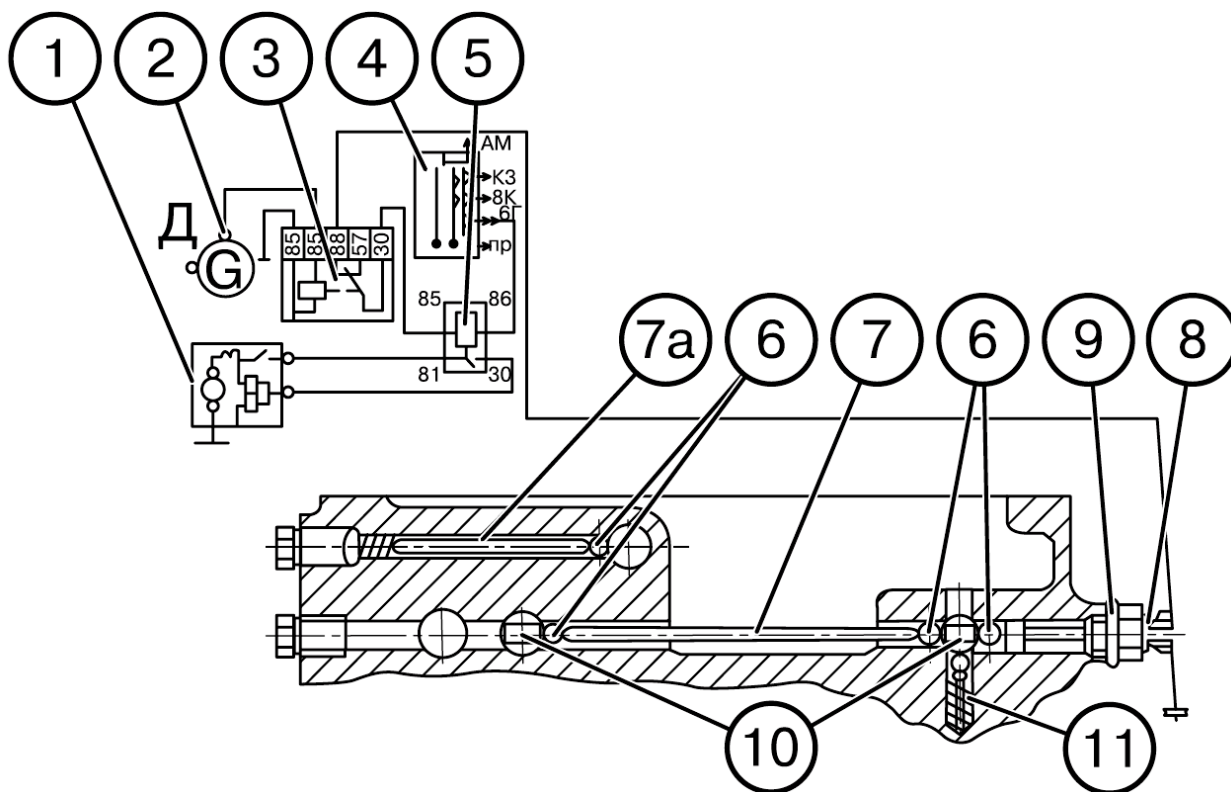

1 – starter; 2 – alternator; 3 – interlock relay; 4 – starter switch; 5 – starter relay; 6 – interlock mechanism (locking) balls; 7, 7a – fingers; 8 – interlock switch; 9 – adjusting shims; 10 – range selection dogs.

**Tractor Speed Diagram, km/h,
at 1400...2100 rpm of the Engine (GB 16F+8R; tyres 520/70R38)**

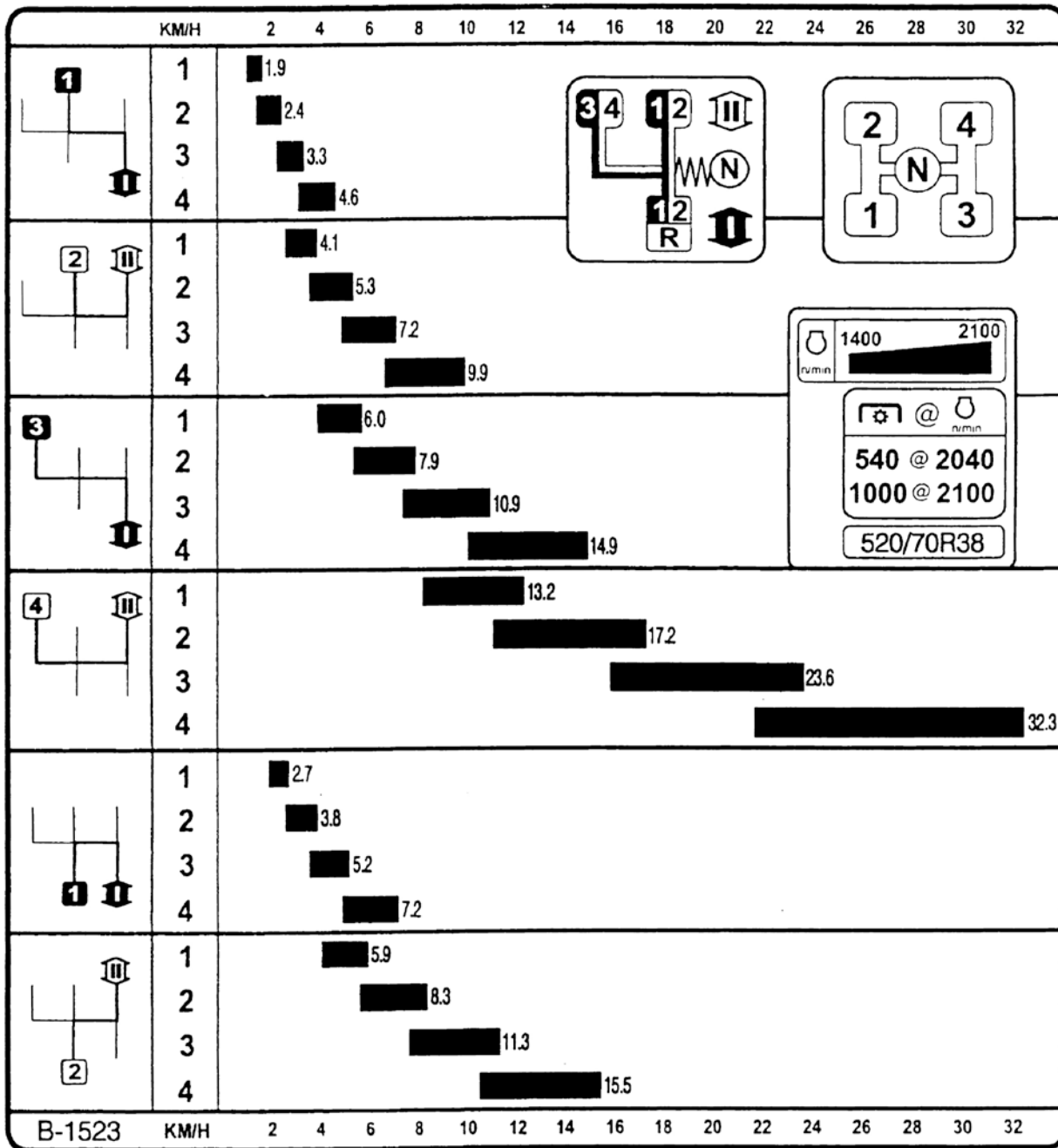

Gearbox (24F+12R)

The gearbox consists of a transmission assembly, a shaft of reduced gears and reverse, a secondary shaft supported in

bearings in the housing as well as a control mechanism and electrohydraulic system units.

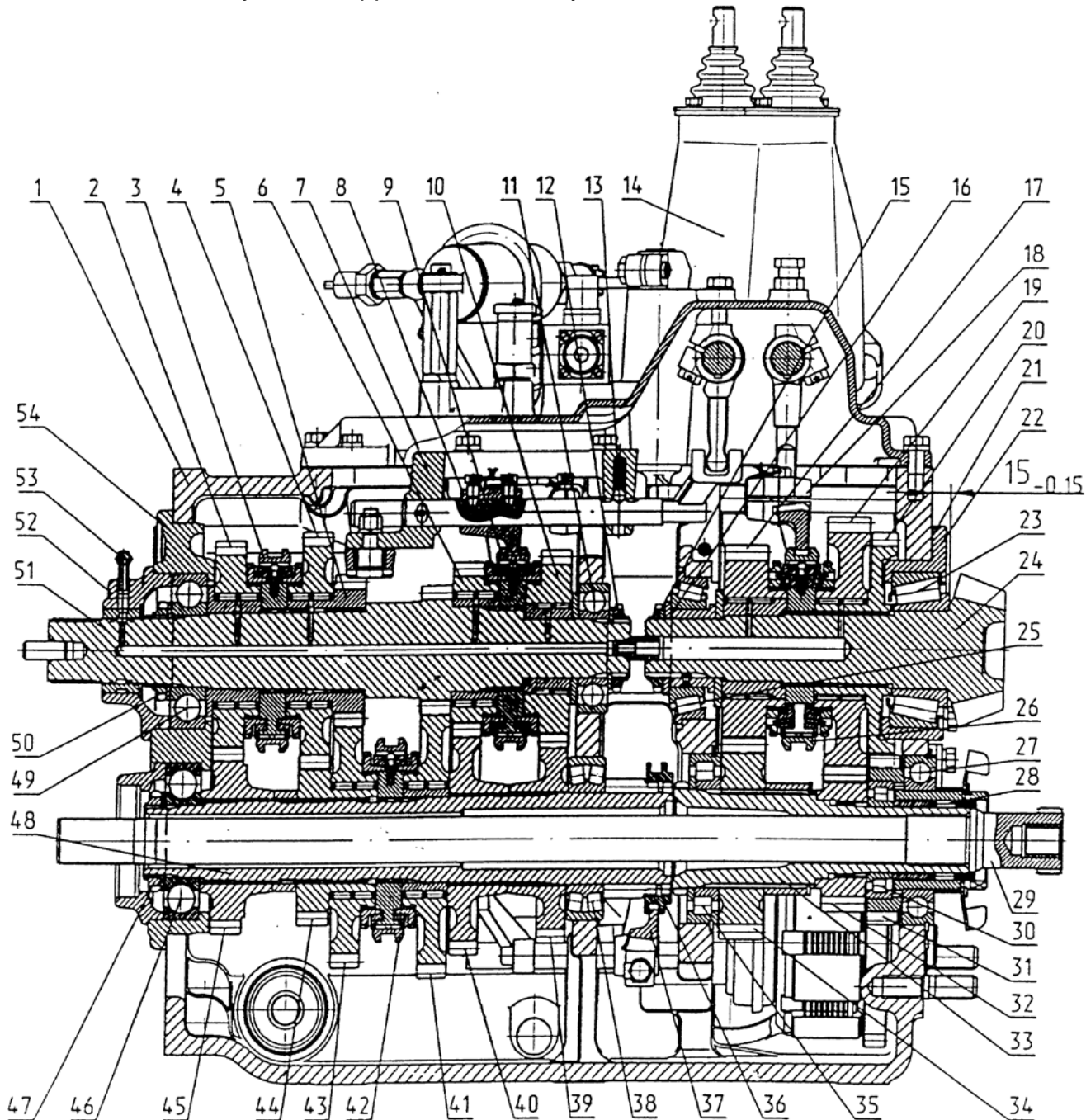

Longitudinal section of the gearbox:

1 – housing; 2, 4, 5, 6, 10, 17, 19, 20, 31, 32, 34, 39, 40, 41, 43, 44, 45 – gears; 3, 9, 26, 42 – synchronizers; 7 – fork box; 8, 18, 37 – forks; 11, 23, 25, 27, 28, 30, 35, 38, 46, 49 – bearings; 11, 15, 47, 50 – nuts; 13 – ball-point lock; 14 – control mechanism; 16, 21 – adjusting shims; 22 – bearing seat; 24 – secondary shaft; 29 – independent PTO drive shaft; 33 – gear cluster shaft; 36 – toothed coupling; 48 – intermediate shaft; 51 – primary shaft; 52 – lubricant feed sleeve; 53 – oil pipeline; 54 – cover.

The **Transmission Assembly** is mounted on the cover (54) and consists of the primary shaft (51) with driving pinions (2, 4, 6, 10), supported in needle bearings, riding thereon. These gears provide for shifting in the fifth, sixth, third and fourth gears, respectively. The first speed driving pinion is made integral with shaft (51) and the second speed driving pinion is rigidly connected to the shaft. The needle bearings are lubricated under pressure through oil pipeline (53) and drillings in the shaft. Two inertia-type synchronizers (4) and (9) are sliding on the shaft splines; they provide for shifting between fifth and sixth, third and fourth speeds. The primary shaft is supported in the roller bearings housed in cover (54) and in housing.

The driven gears (45, 44, 40 and 39) of fifth, sixth, third and fourth speeds, respectively, are interference fitted onto the intermediate shaft (48). Driven gears

(43) and (41) for shifting into first and second speeds, respectively, are supported in needle bearings. An inertia-type synchronizer (42), which helps to engage the first and second speeds, is splined to the shaft.

The Reduced Gears and Reverse Shaft 3 (see Figure below) is supported in bearings (1) and (12), installed in the housing (4). The shaft carries a driven gear (10), which is secured to the shaft by means of the bushings (9), driving forward run pinion (8) and reverse run gear (5), both supported in needle bearings. These gears are connected to the shaft through a toothed coupling (6). The bushing (16) splined on the shaft is stopped with a check ring (7). Should the tractor is equipped with a creeper, a gear to be engaged with the creeper one is mounted instead of the bushing (9).

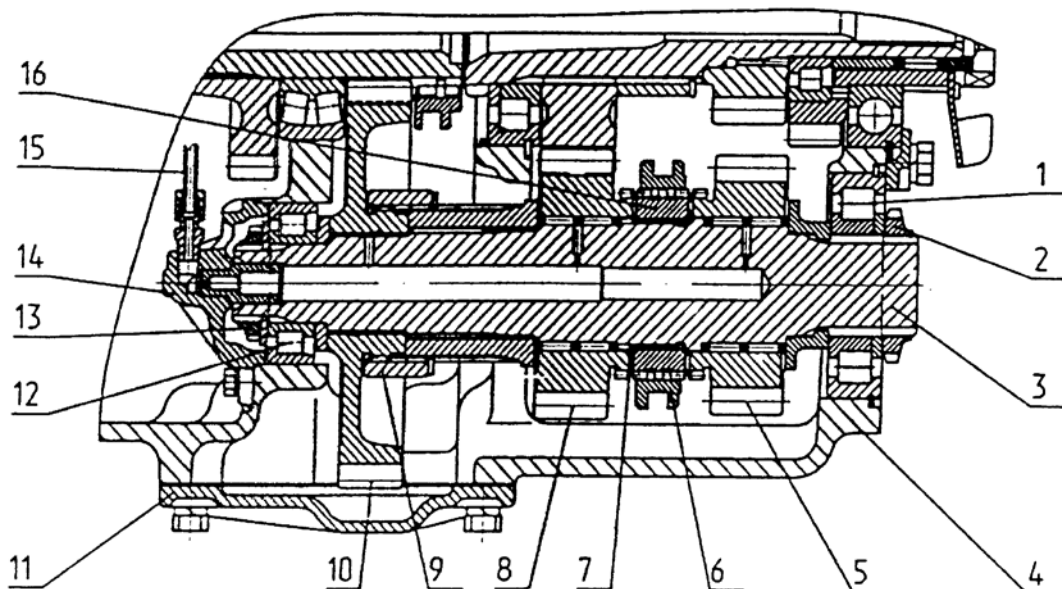

Shaft of reduced gears and reverse

1,12 – bearings; 2, 13 – nuts; 3 – shaft; 4 – housing; 5, 8, 10 – gears; 6 – toothed coupling; 7 – check ring; 9 – bushing; 11 – cover; 14 – oil feed sleeve; 15 – oil pipeline; 16 - bushing.

The Gear Cluster Shaft (33) (see Figure “Gearbox (24F+12R)”) is installed in

the housing (1), supported in bearings (27) and (35). The gears (32) and (34)

are splined to the shaft and stopped with a check ring. The driven gear of the synchronous PTO (31) sits on the shaft in roller bearings (28) and (30).

The **Secondary Shaft (24)** (see Figure "Gearbox (24F+12R)") is installed in the housing (1), supported in conical roller bearings (23) and (25), the latter are adjusted by adjusting shims (16), while the position of the shaft bevel gear relative to the housing end-face (dimension $15^{0.15}$) is adjusted by the selection of adjusting shims (21). A driving pinion (20) of the synchronous PTO and the FDA as well as the synchronizer hub (26) is immovably fitted on the shaft. The driven gears (17) and (19) are installed though needle bearings; they are pressure-lubricated through drillings in the shaft. The gear shifting is achieved by means of a synchronizer (26) and fork (18) fixed on a dog. The dog is installed in the recesses of the housing (1) and locked with a ball-point lock.

The sets of parts installed on the prima-

ry, intermediate and secondary shafts and the shaft of reduced gears and reverse are tightened up with nuts (12, 15, 47 and 50).

GEARBOX CONTROL MECHANISM

The gearbox control mechanism consists of a gearshift mechanism and a range-selector mechanism with an electrohydraulic system for shifting into high (H) and low (L) stages of the gearbox reduction gear.

The **Gearshift Mechanism** is mounted in the transmission gear assembly, the fork box (7) (see Figure "Gearbox (24F+12R)") and in the control mechanism cover (14).

The dogs with the first, second and fifth, sixth gear-shift forks fitted thereon are installed in the cover (54). The dogs are fixed in the cover by means of ball-point locks. The position of the forks is adjusted by means of tapered adjusting screws.

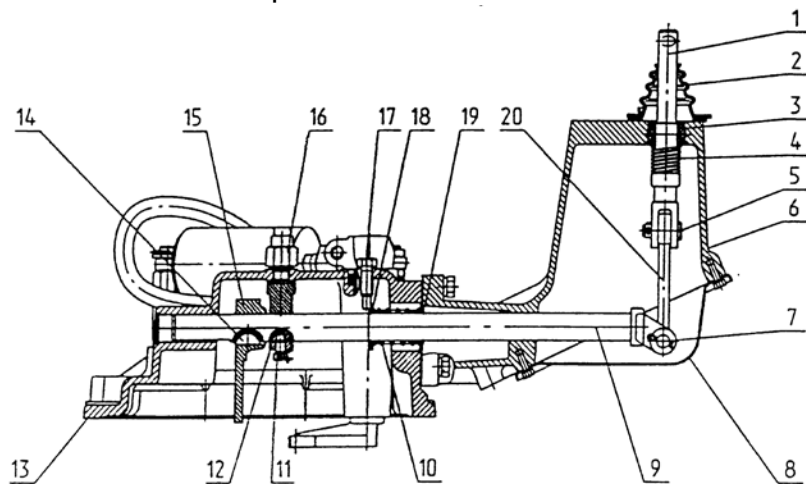

Gearshift mechanism:

1 – fork; 2 – boot; 3 – sphere; 4 – spring; 5, 7 – pins; 6 – housing; 8 – cover; 9 – shaft; 11 – bolt; 12 – bushing; 13 – cover; 14 – sunk key; 14, 20 – lever; 16 – sensor; 17 – screw; 18 – washer; 19 – check ring.

In the fork box (7) (see Figure “Gearbox (24F+12R)”), the three dogs, fork (8), ball-point lock (13) and parts of the interlock mechanism for preventing the simultaneous engagement of two gears are installed. The fork box is fastened to the gearbox housing (1).

A shaft (9) with attached lever (15) and bushing (12) is installed in the cover (13) supports and the housing (6) (see Figure “Gearshift Mechanism”); the two bushings (18) and spring (10) are mounted between the check rings (19). The bushings rest against the screw (17) and the housing (6) end-face with their ends. This mechanism serves for positioning the gearshift lever to its neutral position. The shaft (9) is connected with the fork (1), to which the gearshift lever is attached, by means of the dogs (5) and (7), and lever (20). The fork (1) is installed in the housing (6) through a sphere (3); it is supported by spring (4).

The Range-Selector Mechanism is

mounted in the gearbox housing (1) (see Figure “Gearbox (24F+12R)”) and in the gearshift mechanism cover (14).

The fork (37) for shifting the toothed coupling (36), fork for shifting the toothed coupling (6) (see Figure “Shaft of reduced gears and reverse”) and fork (18) for shifting the synchronizer (26) (see Figure “Gearbox (24F+12R)”) are mounted on the dogs in the housing (1). The dogs are fixed in the housing with ball-point locks.

The shaft (9) with the levers (10) keyed thereon is installed in the supports of the cover (12) and housing (18) of the control mechanism (see Figure below). The shaft (9) is fixed with a ball-point lock (14) and connected with the fork (1), on which the range-shift lever is fitted, through the dogs (5) and (7) and lever (6). The fork (1) is installed in the housing (18) in sphere (3) and supported by spring (4).

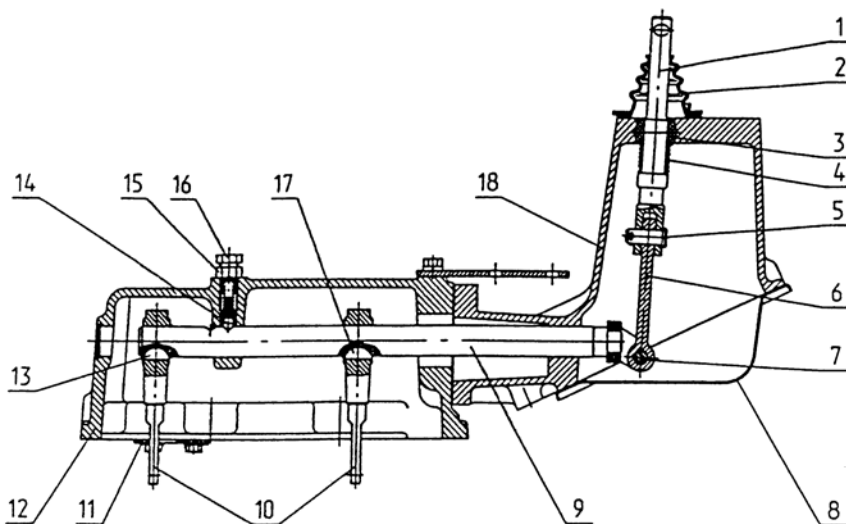

Range-shift mechanism

- 1 – fork, 2 – boot, 3 – sphere, 4 – spring, 5, 7 – pins, 6, 10 – levers, 8, 12 – covers, 9 – shaft, 11 – gate, 13, 17 – keys, 14 – ball-point lock, 15 – nut, 16 – bolt, 18 – housing.

The Higher-Lower Stage Selection Mechanism of the Reduction Gear of the gearbox (see Figure below) is mounted on the shifting mechanism cover and consists of a cylinder (11) secured on axle (12), pusher (7), and lever (5) fixed on the spindle (4). The pusher (7) is jointed with the lever (5) by means of pin (6). The lever on spindle (4) comes into engagement with the dog of fork (18) (see Figure "Gearbox (24F+12R)") and, when the spindle turns, shifts the synchronizing sleeve (26). The position of the lever (5) (see Figure below) is adjusted by changing the pusher (7) length, with further locking it with lock-nut (8). The cylinder (11) is connected to the hydraulic system through an electrohydraulic valve (14). The sensor (15) connects the valve (14) to the electrical circuit only when the gearshift lever is in its neutral position. The drawn-in position of the cylinder (11) rod corresponds to the lower

"L" stage of the gearbox reduction gear. Sensors (10) serve to indicate that the reduction gear stage is engaged. For adjusting the cylinder (11), move the piston into the cylinder as far as it will go. Turn the lever (5) counter-clockwise having engaged the reducing range of the gearbox reduction gear. Screw in the pin (7) by 8-9 revolutions and lock the same by means of the nut (8). Align the holes in the lever (5) and fork (16) by means of the pin (6) and lock the same with a nut. Turn the lever (5) clockwise having engaged the speeding-up range of the gearbox reduction gear. Draw out the rod of the cylinder (11) and align the holes in the lever (5) and those in the fork (16). Connect the lever (5) and the fork (16) by means of the pin; then refit the washer and the cotter pin. Turn the (18) in or out until the spherical part of the bolt rests against the lever (5) and lock the same with a nut.

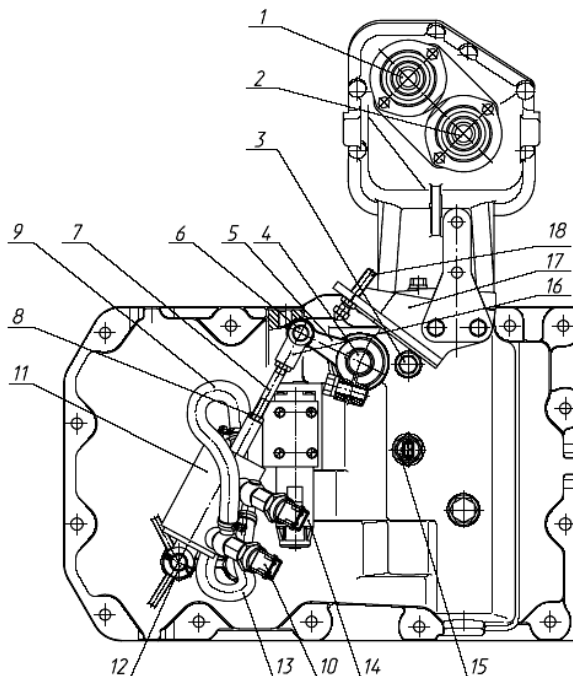

1 – gearshift fork, 2 – range-shift fork, 3 – bolt, 4 – spindle, 5 – lever, 6 – pin, 7 – pusher, 8 – lock-nut, 9, 13 – oil pipelines, 10 – pressure sensor, 11 – hydraulic cylinder, 12 – axle, 14 – electrohydraulic valve, 15 – sensor; 16 – fork; 17 – bracket; 18 – adjusting screw.

**Speed Diagram of the Tractor, km/h,
at 1400...2100 rpm of the engine crankshaft (GB 24F+12R; tyres 520/70R38)**

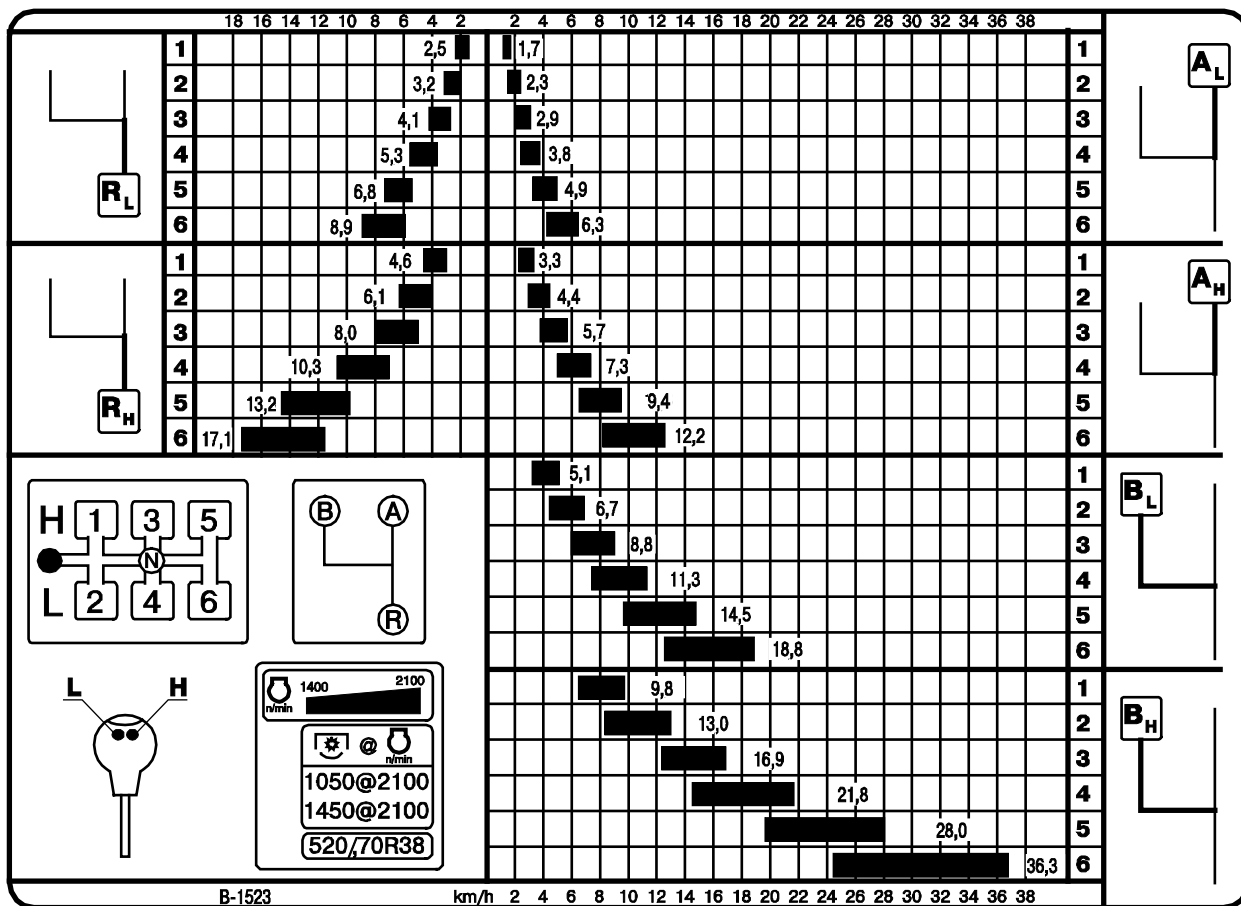

GEARBOX REDUCTION GEAR CONTROL SYSTEM

The **Electrohydraulic System** incorporates a control panel (1) located in the tractor cab to the right of the operator, lever (3) for shifting gears and selecting the reduction gear stages, GB neutral position sensor (5), transducers (7) and (8) installed on the reduction gearshift hydraulic cylinder, electrohydraulic distributor (6) mounted on top of the GB cover and connecting cables (4) with terminal blocks (9). The system is energized from the on-board electric circuit through a safety fuse box (2). The electrical power is supplied to the system before starting the engine (after turning the starter and instrumentation switch to the "Instrumentation Supply" position). The buttons (10, 11) and annunciators (LEDs) (13, 12) for engaging the lower and higher stages of the reduction gear are fitted on the handle of the lever (3), respectively. The warning lights (15 and 14) of engagement of the lower and higher stages of the reduction gear and the reduction gear control relay are located on the

panel (1).
ATTENTION! This system allows the reduction-gear stages to be selected only provided the lever (3) is in neutral position (i.e. the sensor (5) contacts of the GB neutral are closed). The reduction gear stages shall be switched over on the stopped tractor.

The signals are sent to the annunciators (13, 12) and warning lights (15, 14) from the respective pressure transducers (8 and 7). After starting the engine, the reduction gear lower stage is initially engaged. When it will be done, the annunciator (13) and the warning light (15) shall light up. Upshifting to the reduction gear higher stage is achieved by pressing the button (11). At the same time, the lights (13 and 15) shall go out and the annunciator (12) and the warning light (14) shall light up. Downshifting from the higher to lower stage is done by pressing button (10). The electric diagram of the GB reduction gear, differential interlock and FDA controls is shown in the Section "Appendix".

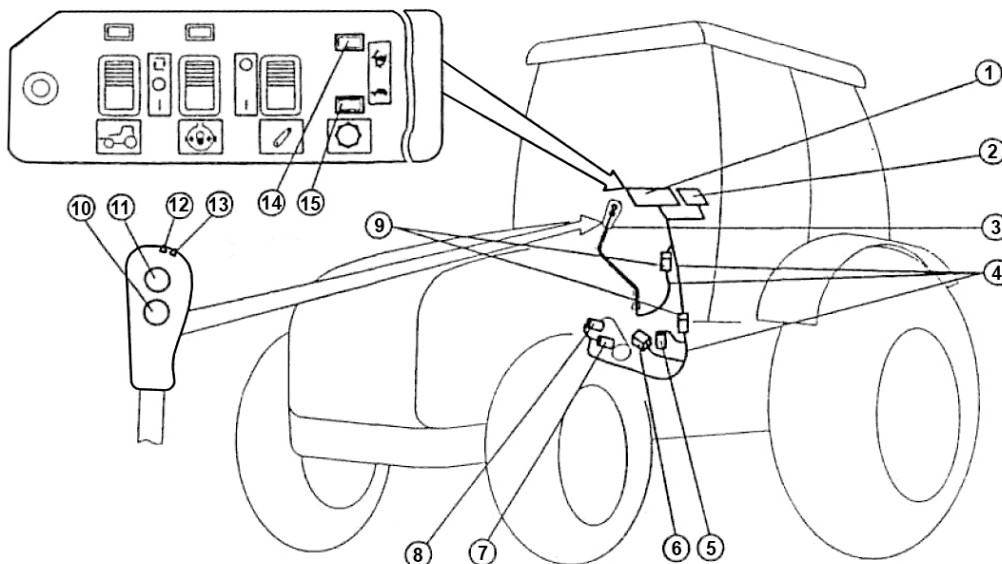

1 – control panel; 2 – safety fuse box; 3 – lever for shifting gears and selecting the reduction gear stages; 4 – connecting cables; 5 – GB neutral sensor; 6 – electrohydraulic distributor of the reduction gear; 7 – higher stage pressure transducer; 8 – lower stage pressure transducer; 9 – terminal blocks; 10 – lower stage selection button; 11 – higher stage selection button; 12 – light-emitting diode (LED) of the higher stage; 13 - light-emitting diode (LED) of the lower stage; 14, 15 – warning lamps.

CREEPER (if installed)

Purpose and Scope of Application

The creeper is intended for installation on the tractors operated with the machines requiring reduced speeds of movements (reapers, snow ploughs, crop collectors, etc.).

Using the creeper makes it possible to reduce additionally the tractor speed in four gears of the first range of the forward and reverse movement each 4.5 times.

The calculated speeds of movement of the tractor with the creeper engaged are:

- in the forward movement: 0.384, 0.537, 0.738 and 1,01 km/h, respectively;

- in the reverse movement: 0.603, 0.844, 1.159, 1.587 km/h.

Should it be necessary to use the gears of the first range of the forward and reverse movement of the gearbox with their rated gearing ratios, it would be sufficient to disengage the creeper.

Construction and principle of operation

The creeper is an independent easily removable assembly and designed as a planetary spur-gear speed reducer to be installed on the left of the gearbox (GB) as seen in the direction of movement of the tractor to provide the process range of the tractor movement speeds.

Kinematic diagram of the creeper

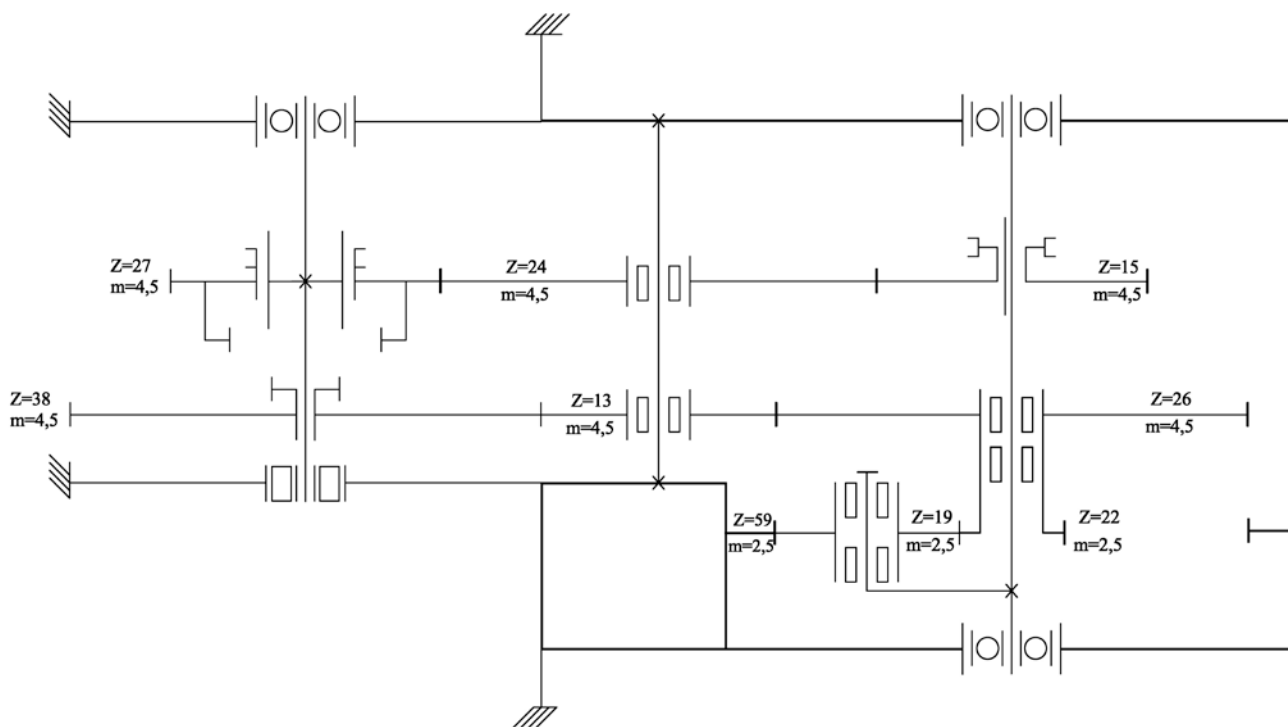

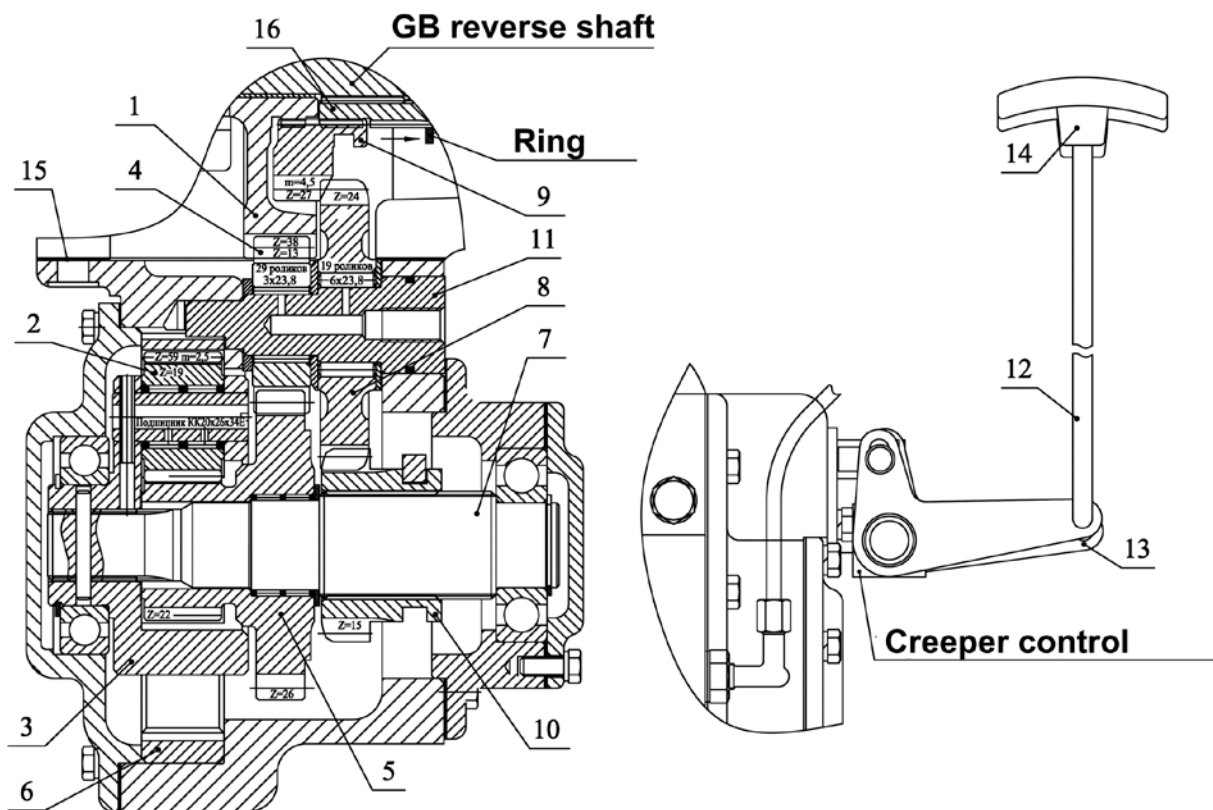

Creepers:

1 – gearbox gear; 2 – planet pinion; 3 – pinion cage; 4,8 – intermediate gear of the creeper; 5-double-wheel gear; 6 – crown gear; 7 – shaft; 9 – creeper drive gear; 10 – pinion; 11 – creeper shaft; 12,13 – rod; 14 – handle; 15 – gasket; 16 – bushing.

The torque from the engine is transmitted from the gearbox gear (1) to the planet pinions (2) of the creeper pinion cage (3) through the intermediate gear of the creeper (4) and double-wheel gear (5) and from the pinion cage through the mesh of the planet pinions (2) with the crown gear (6) of the plane-

tary spur-gear speed reducer. The crown gear (6) is mounted immovably in the creeper casing onto the output shaft of the planetary spur-gear speed reducer (7). The pinion (10) transmitting the torque to the gearbox reverse shaft gear (9) through the intermediate gear (8) on the output shaft (7).

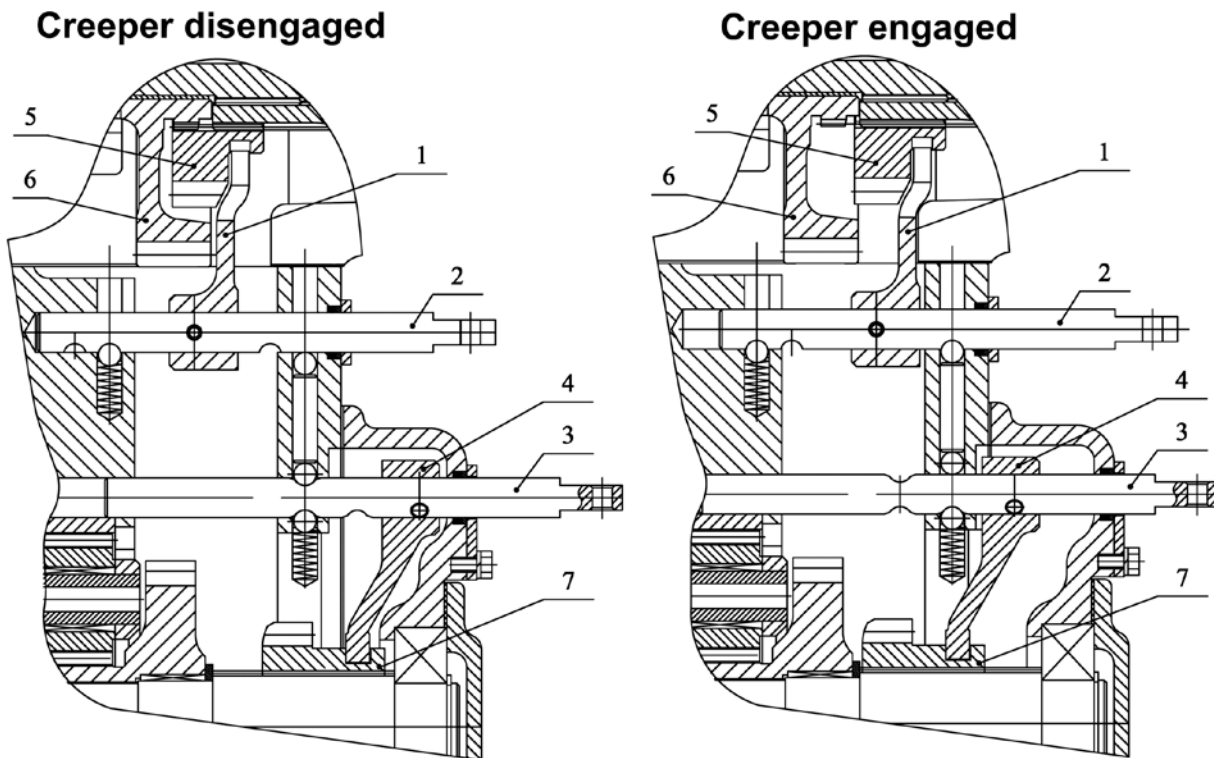

Creeper interlocking mechanism:

1,4 – fork; 2,3 – pusher; 5,6,7 – gear.

To engage the creeper, it is necessary, first of all, to disengage the gears (5) and (6) in the gearbox. It is achieved by moving the pusher (2) to the right to the position fixed by the spring-loaded ball. Here the fork (1) fixed on the pusher (2) disengages the gears (5) and (6) and brings the gear (5) into complete mesh with the intermediate gear (8) (see Figure “Creeper”) of the creeper. Then the gear (7) is brought into mesh with the intermediate gear (8) (see Figure “Creep-

er”) by moving the pusher (3) (see Figure “Creeper interlocking mechanism”) with the fork (4) to the left to the fixed position.

Thus, the power flow from the driving gear (1) (see Figure “Creeper”) is brought to the driven one (9) of the gearbox. The interlocking mechanism excludes the possibility of simultaneous movement of both fork and, respectively, rods as well as ensures the priority of their engagement.

Creep Control

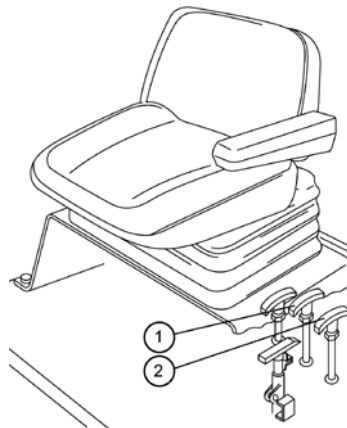

Set the stable idling rotational speed of the engine; the GB lever shall be in the neutral position.

The creeper is controlled by means of the rods (1) and (2).

In the "Creeper disengaged" position, the rod (1) is lifted while the rod (2) is depressed. In the "Creeper engaged" position, the rod (1) is depressed while the rod (2) is lifted.

The engagement of the creeper is performed in two stages:

- To engage the creeper, set the minimum stable rotational speed of the engine. Move the rod (1) downwards having depressed smoothly the clutch pedal;

- Move the rod (2) (at longer distance from the operator) upwards having depressed the clutch pedal again.

To start the movement, it is necessary to shift in the necessary gear and release smoothly the clutch pedal.

Engaging the creeper does not cause the change of the tractor movement direction.

The gears of the first forward range and reverse range shall be shifted with the clutch pedal depressed and with short (20...30 s) delay of the gear disengagement.

Operation Rules

Prior to operation of the tractor with creeper, check the oil level in the transmission. The oil level shall not be below the upper control hole of the oil level gauge scale. If necessary, add oil.

ATTENTION! To avoid breakdowns in the transmission and overheating of oil, the tractor with creeper shall be only operated in the gears of the first range of forward and reverse motion of the gear-box.

The permissible oil temperature is not more than 100°C. After every 250 running hours of the tractor with creeper, check the oil level in the transmission, absence of leakages and tightness of threaded connections.

When operating the tractor at normal speed conditions, the creeper shall be obligatorily disconnected from the gear-box (the left rod being at longer distance from the operator is depressed).

Should it be planned to use the tractor at normal speed condition, the creeper shall be removed from the tractor to avoid the premature wear of the parts.

REAR AXLE

The rear axle consists of the rear-axle drive, differential with a hydraulically controlled lockup friction clutch, final drives

located in the rear-axle housing, and hub drives located in the axle-shaft housings.

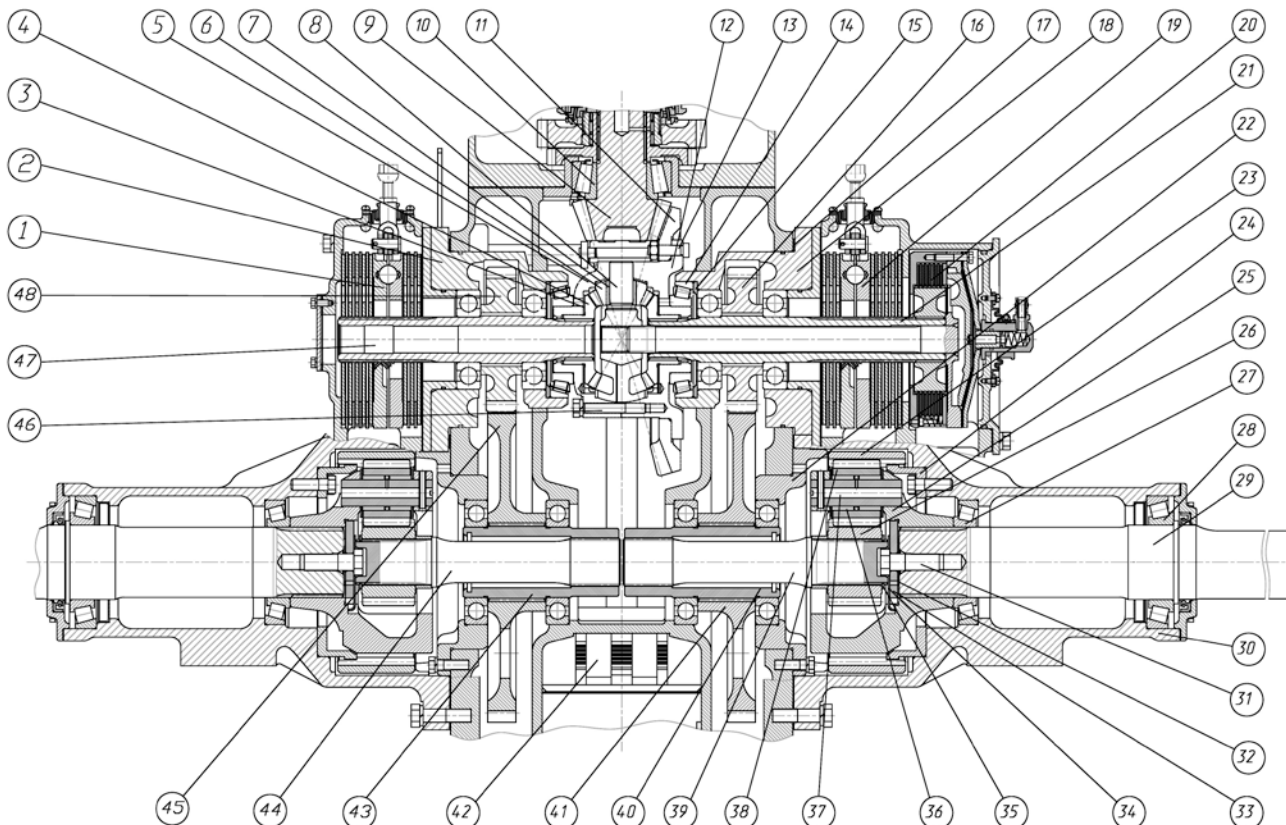

1 – left-hand brake; 2, 18 – bearing shells; 3 – bearing washer; 4 – axle-shaft pinion; 5 – differential cover; 6 – satellite; 7 – spherical washer; 8 – differential spider; 9 – rear-axle drive pinion; 10 – tapered roller bearing; 11 – driven gear; 12 – differential housing; 13 – bolt; 14, 27, 28 – tapered roller bearing; 15 – thrust ring; 16, 48 – hub drive driving pinion; 17, 32 – adjusting shims; 19 – right-hand brake; 20 – differential lockup clutch; 21 – right-hand driving pinion shaft; 22 – bearing shell; 23 – crown gear; 24 – crown gear boss; 25 – pinion carrier; 26 – sun gear; 29 – axle-shaft; 30 – axle-shaft housing; 31 – bolt; 33 – washer; 34 – check plate; 35 – washer; 36 – roller; 37 – satellite shaft; 38 – satellite; 39, 44 – torsion shaft; 40, 43 – driven gear bush; 41, 45 – driven gear; 42 – rear PTO; 46 – bolt; 47 – left-hand drive gear shaft.

Main Rear-Axle Drive

The rear-axle drive is conical one with a spiral bevel gearing. It consists of a driving bevel pinion (9) made integral with the GB secondary shaft, and a driven gear (11) bolted (13) to the differential housing (12).

Differential

The lockable bevel-gearing closed-type differential consists of the housing (12) and cover (5) joined with bolts (46), differential spider (8), four satellites (6) with spherical washers (7) and two axle-shaft gears (4) with their bearing washers (3). The differential housing assembly is supported in the rear-axle housing in two roller bearings (14). To lockup the differential, there is hydraulically controlled multi-disk friction clutch (20). It locks the differential spider and the satellites with the right-hand axle-shaft gear of the differential.

Final Drives

The final drives involve two pairs of spur gears (16, 41) and (45, 48).

The driving pinions (16, 48) of the final drives are splined to the shafts (21, 47), respectively, and supported in roller bearings. The axial fixing is attained by means of the thrust rings (15).

The shafts (21) and (47) connect the axle-shaft gears (4) of the differential with the driving pinions of the final drives and brake disks by their splines.

Driven gears (41, 45) sit on splined bushings (40, 43) and are supported in ball bearings.

The adjusting shims (17) with the thicknesses of 0.2 mm and 0.5 mm are placed between the flanges of the shells (18) and housing of the rear axle for adjusting the axial clearance in the tapered roller bearings (14) and the lateral clearance in the main drive gear (9) and (11) meshing.

Hub Drives

The hub drives consists of two spur gears, located in the axle-shaft housings, of the planetary mechanism, torsion shafts (39, 44) with the splines which connect the driven gears (41, 45) of the final drives with the planetary mechanisms.

The planetary mechanism consists of a fixed crown gear (23) bolted through its hub (24) to the housing (30), carrier (25) of the sun gear (26), rigidly connected to the torsion shaft (39), and four satellites (38) installed on the pins (37) by means of rollers (36).

The bearings (27, 28) are adjusted by choosing pack of appropriate shims (32) 0.2 mm and 0.5 mm thick.

Differential lockup Clutch

A multi-disk hydraulically controlled differential lockup clutch (2) is located in casing (1), which, through the casing of

the right-hand brake (11) and the bearing shell (12), is fastened by bolts (16) to the rear axle housing.

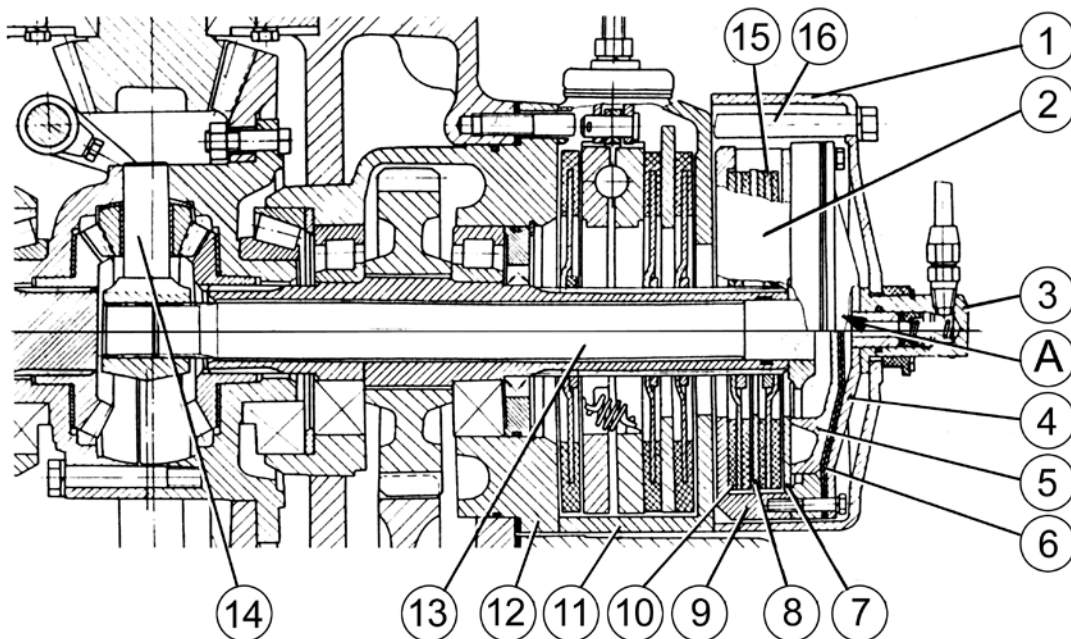

1 – casing; 2 – lock clutch; 3 – adapter; 4 – diaphragm cover; 5 – pressure plate; 6 – diaphragm; 7 – release plate; 8 – intermediate disk; 9 – clutch housing; 10, 15 – brake disks; 11 – right-hand brake case; 12 – bearing shell; 13 – lockup shaft; 14 – differential spider; 16 – bolt.

The clutch is composed of a shaft (13) which is connected by means of splines with the differential spider (14), casing (9), pressure plate (5), release plate (7), diaphragm (6), cover (4), adapter (3) and disks (10, 15) splined on the right-hand driving pinion of the hub drive.

When oil is fed under pressure into the working chamber “A” from the ADL hydraulic system, the diaphragm (6) moves together with the pressure plate (5) and press the disks (10, 15) against surfaces

of the casing (9), intermediate disk (8) and that of the release plate (7), thus, locking the differential (i.e., the differential spider gets interlocked with the right-hand axle-shaft gear). When the chamber “A” communicates with the drain, the differential gets unlocked.

The normal position of the lock clutch is disengaged.

Rear Axle Differential lockup (Rear Axle DL) Control System

The rear axle DL control system consists of a control panel (1) located in the tractor cab, on the right side of the operator; steering angle sensor (10) installed on the FDA on the left-hand side; two service brake engagement sensors (13) located below the brake pedals; electrohydraulic distributor (6) installed on the right-hand cover of GB and hydraulically

coupled to the rear axle DL friction clutch; connecting cables (9) with a plug-in socket (4) and terminal connectors (12). The system is fed from the on-board electric circuit through a safety fuse box (2). The electric power is only fed after starting the engine, from the starting relay block (3).

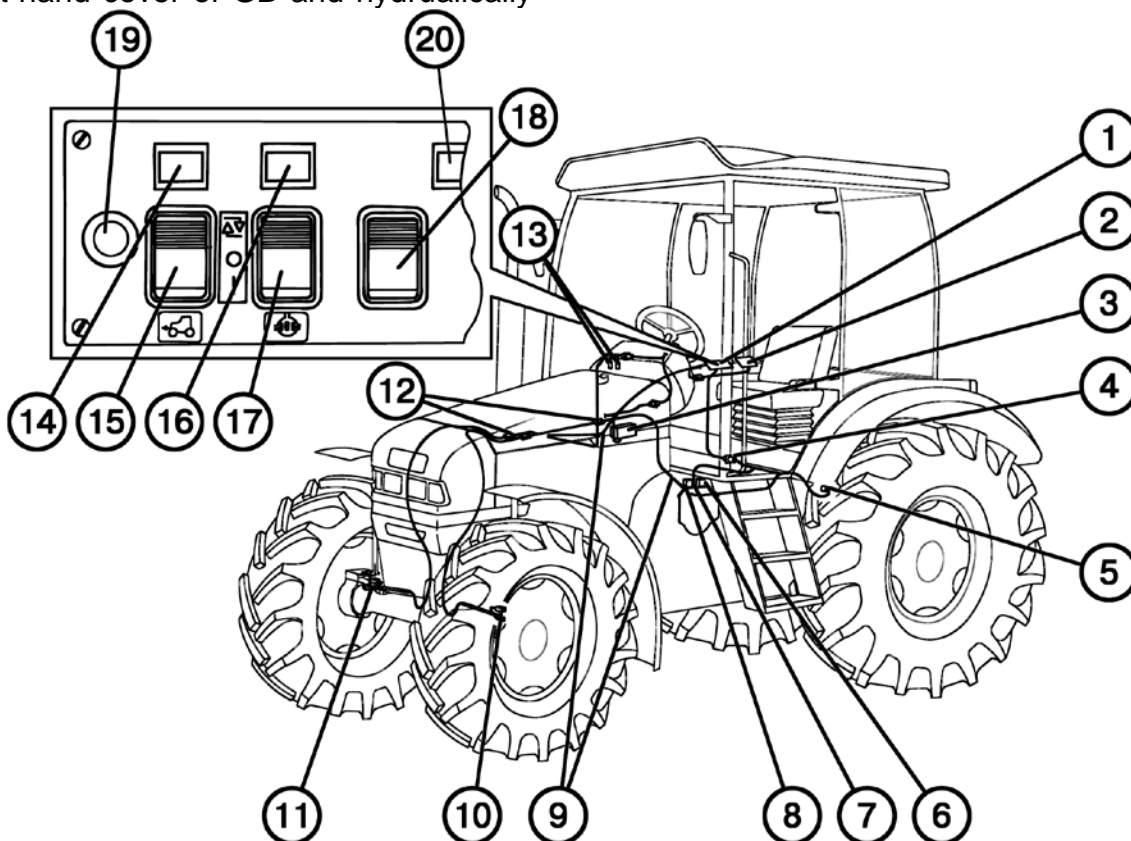

Differential lockup (DL) control system for the rear axle and the frond drive axle (FDA):
 1 – control panel; 2 – safety fuse box; 3 – starting relay block; 4 – plug-in socket; 5 – reverse sensor; 6 – DB control electrohydraulic distributor; 7 – sensor of automatic engagement of the FDA drive; 8 – FDA drive control hydraulic distributor; 9 – connecting cables; 10, 11¹ – steering angle sensors: +13 deg. and +25 deg., respectively; 12 – connector terminals; 13 – service brake applied sensors; 14, 16, 20 – warning lights; 15 – FDA drive control selector switch; 17 – DL control selector switch; 18 – Front PTO (FPTO) switch (if installed); 19 – horn switch (1523B).

¹ If installed

The panel (1) accommodates the key-switch (17) of the rear axle DL control and a warning light (16) of the rear axle DL engaged state.

The key-switch (17) has three positions:

- Automatic lockup (upper fixed position);
- Forced lockup (lower non-fixed position);
- Lockup disengaged (fixed middle position).

In the “Lockup disengaged” position of the switch (17) the electrohydraulic distributor (6) is devoid of electric power supply; the rear axle DL clutch communicates with the drain pipeline, and the rear axle differential is unlocked.

In the “Automatic Lockup” position of the switch (17) (when performing the farming jobs with considerable relative slipping of the rear wheels), the electrohydraulic distributor (6) is energized; it directs the oil flow under pressure towards the rear ax-

le DL clutch and locks the differential. Unlocking of the differential will be effected automatically whenever the steering wheels will turn through an angle which exceeds 13° in any direction or whenever one or both service brakes are applied.

If temporary lockup of the rear wheels is required, including situations with turns, press down the lower part of the key-switch (17), set it in the “Forced Lockup” position and retain it therein. When the key-switch is released, unlocking results (“Lockup Disengaged”).

ATTENTION! With the differential lock mechanism engaged, the tractor ground speed should not exceed 12 km/h. NEVER operate the tractor on haulage missions over hard-surfaced roads with the differential constantly locked!

REAR POWER TAKE-OFF SHAFT (PTO)

The rear PTO is provided with the two-speed (for tractors with the GB 16x8) or four-speed (for tractors with the GB 24x12) independent drive. The drive is provided by means of a two-speed reduction gear in the clutch housing and interchangeable tail-pieces: (15) (540 rpm) and (16) (1000 rpm) in the PTO reduction gear.

The tractors with the GB 24x12 are provided with the selector of the independent PTO drive speed (A) which is located to the left of the clutch housing and makes it possible to obtain additionally two PTO speeds. It has two positions:

I – 540 and 1000 rpm – extreme counter-clockwise;

II – 651 and 1435 rpm – extreme clockwise.

To set the necessary rotational speed of the PTO, release the bolt (B), turn the

lever to the necessary position and tighten the bolt (B).

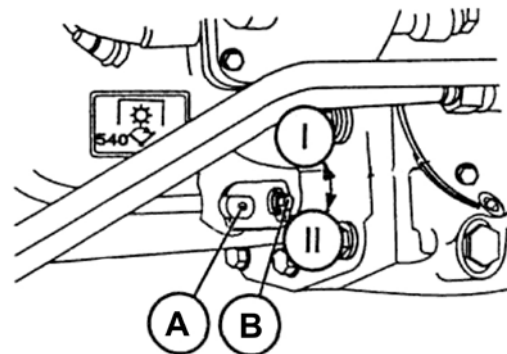

The drive is provided from the engine through the two pairs of cylindrical gears in the clutch housing, internal GB shaft, changeover clutch and PTO reduction gear. The drive is switched on and off by means of the clutch (1).

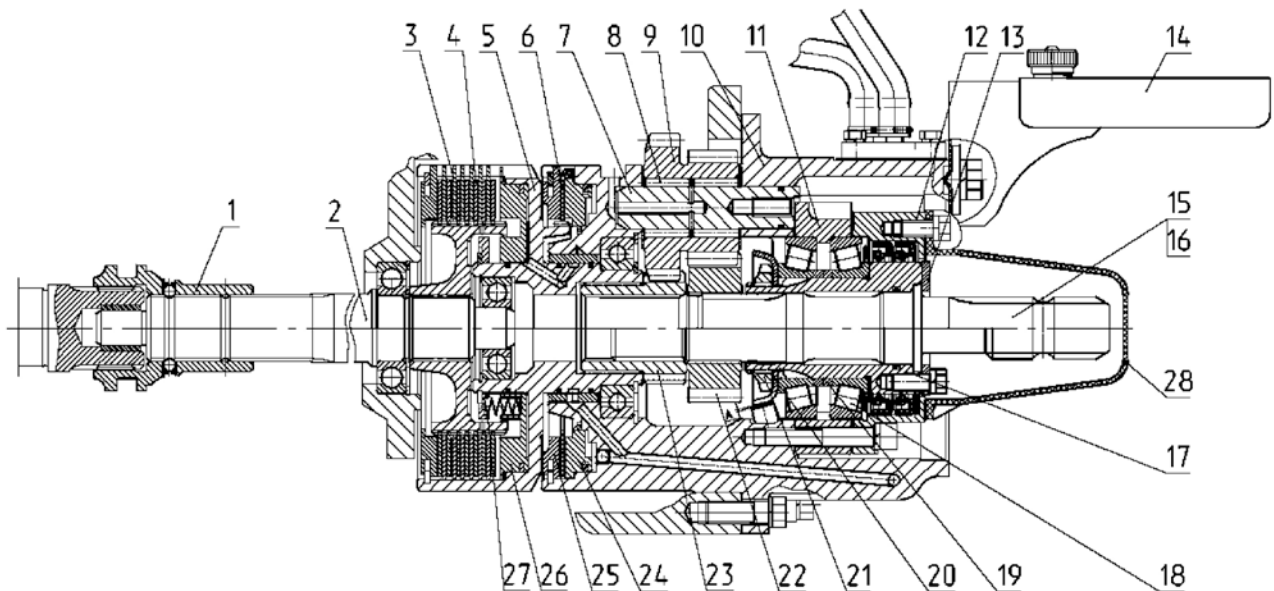

Rear power takeoff shaft

1 – changeover clutch; 2 – driving shaft; 3 – friction disk; 4 – intermediate disk; 5 – drum; 6 – brake plate; 7 – intermediate shaft; 8 – roller; 9 – gear; 10 – housing; 11 – sleeve; 12 – cap; 13 – thrust washer; 14 – cover; 15, 16 – interchangeable tail-pieces; 17 – bushing; 18 – taper roller bearing; 19 – ring; 20 – washer; 21 – nut; 22, 23 – pinion; 24 – brake piston; 25 – thrust plate; 26 – friction piston; 27 – spring; 28 – cap.

The PTO reduction gear is installed in the rear axle housing and consists of the

driven pinion (22) and the driving one (23) which are arranged coaxially and

interconnected by means of three equidistant intermediate gears (9) mounted on the axles (7) pressed into the housing of the reduction gear (10).

The driving and driven gears have splines holes through which they are connected with the interchangeable tail-pieces (15, 16) depending on the duty to be performed: when in mesh with the pinion (22), the rotational speed of 540 rpm is provided and when in mesh with the pinion (23) – 1000 rpm.

The tail-pieces are supported in the taper roller bearings (18) and locked against axial displacement by means of the thrust washer (13) and tail-piece shoulder. To change the tail-piece, remove the washer (13), fit another tail-piece and lock it. The marks "540" and "1000", respectively, are made at the tail-piece ends. The PTO is engaged and disengaged by the multi-disk friction clutch and the PTO brake. Disks (3) fitted with metal-ceramic liners are installed on the outer splines of the friction clutch driving shaft (2) and steel disks (4) are installed in cuts in the drum (5) connected with the reducing gear driving

pinion (23) by means of splines. On engaging the PTO, the piston (26) presses the disks to one another under oil pressure and connects in such a way the PTO reduction gear with the driving shaft (2).

On disengaging the friction clutch, the piston (26) returns to its initial position under the force of the springs (7). The independently controlled PTO brake eliminates the tail-piece dragging and ensures its stopping. The brake is mounted in the reduction gear housing (10) and consists of a piston (24), friction plate (6) and thrust plate (25). The friction plate (6) is splined to the drum (5). On applying pressure to the brake booster, piston (24) presses the disks (6) and (25) to one another and brakes the drum and the PTO tail piece.

Note:

The axial clearance in the taper roller bearings (18) shall not exceed 0.10 mm. The adjustment shall be performed by selecting the rings (19). The nuts (21) shall be tightened with the torque of 220 N-m.

Rear PTO Control

The control is achieved by means of handle (1) (see Figure "Rear PTO control") of the switch located on the side control panel. On moving the handle, the lever (22) of the tap for controlling the oil flow being fed to the PTO friction (26) by means of the cable (6) and rod (12) (see Figure "Rear power takeoff shaft") and PTO brake piston (24). To ensure the smoothness of the PTO engagement, the dumper (9) (see Figure "Rear PTO control") is installed at the friction input.

The handle (1) has two positions:

- foremost – "PTO Engaged";
- rearmost – "PTO Tail-Piece Brake Engaged";

The distributor lever (22) has two fixed positions: the lower one "Brake applied" and the upper fixed one "PTO engaged".

The PTO starts operation with the engine running (if the transmission hydraulic system is under working pressure).

To adjust the rear PTO controls, proceed as follows:

- Set the changeover handle (1) to the rear position and the lever (22) of the PTO control tap (13) to the bottom position.
- Align the holes in the fork (3) and switch lever (23) as well as in the rod (12) and lever (22) of the PTO control tap by changing the length of the cable

link (5) (by screwing the fork (3) on and out having loosened preliminarily the locknut (4)) and rod (12) with the coupling (11) (by screwing it on or from the rod having loosened preliminarily the

locknut (4)), connect them by means of the pins and lock them with cotter pins. On completing the adjustment, tighten the locknuts (4).

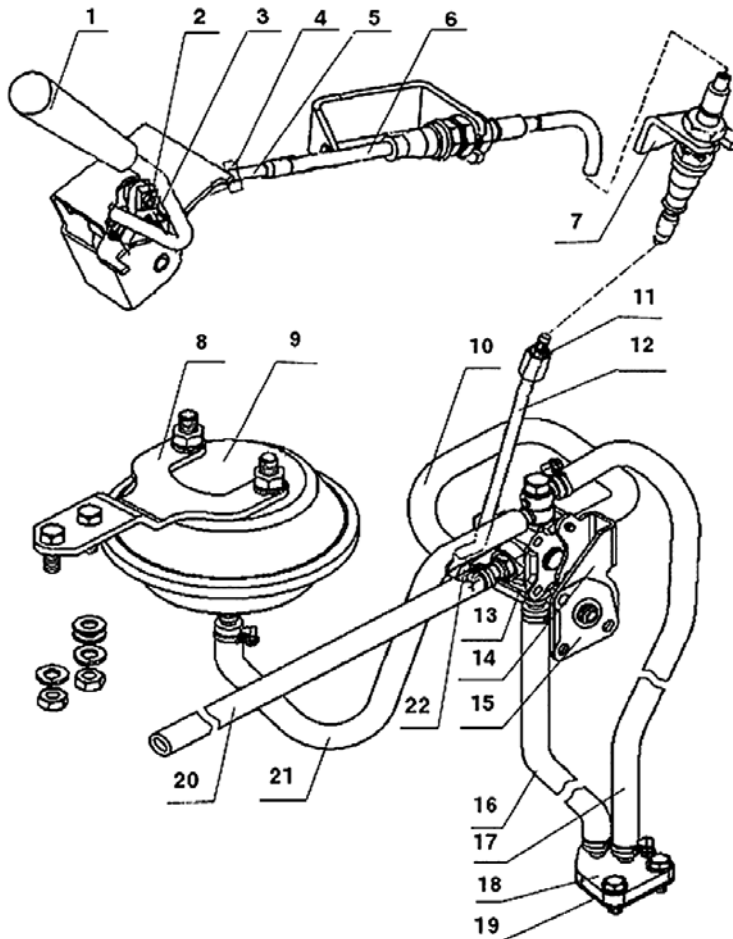

Rear PTO control

1 – control handle; 2 – pin; 3 – fork; 4 – locknut; 5 – cable link; 6 – cable; 7, 8, 14 – bracket; 9 – dumper; 10 – drain hose; 11 – coupling; 12 – rod; 13 – rear PTO control tap; 15, 19 – gasket; 16 – brake hose; 17 – friction hose; 18 – flange; 20 – oil supply hose; 21 – dumper hose; 22 – PTO control tap lever; 23 – switch.

Check the operation of the control mechanism. The control handle (1) shall move without jamming and fix positively in the three positions under the force of not more than 30 N (3 kgf) applied.

ATTENTION! When engaging the PTO, move the control lever smoothly to avoid breakages of the driving shaft, reduction gear parts and PTO tail-piece.

FRONT PTO (if installed)

The front PTO shaft (FPTO) serves to drive agricultural machines installed on the front-end hitch linkage. It is independently driven, with the tail-piece rotating clockwise, if viewed from its end-face. The shaft provides for the rotational speed of the tail-piece 1000 rpm at the

engine crankshaft 1845 rpm, with the output power of up to 44 kW (60 hp).

The FPTO drive is derived from the engine crankshaft pulley (1) to the reduction gear (4) through a distance piece (2) constantly installed in the pulley (1) and a universal-joint shaft (3).

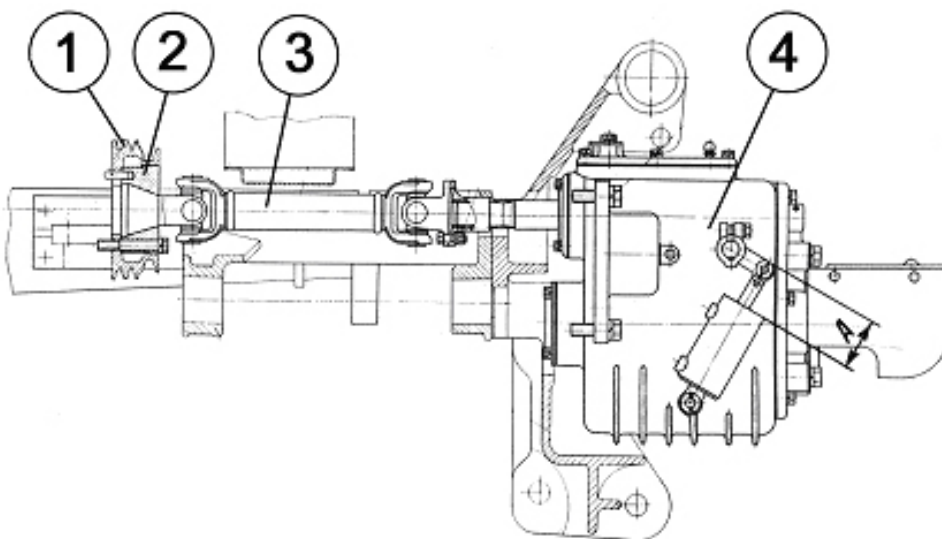

1 – pulley; 2 – distance piece; 3 – universal-joint shaft; 4 – FPTO reduction gear box
 "A" is the amount of the rod extended part

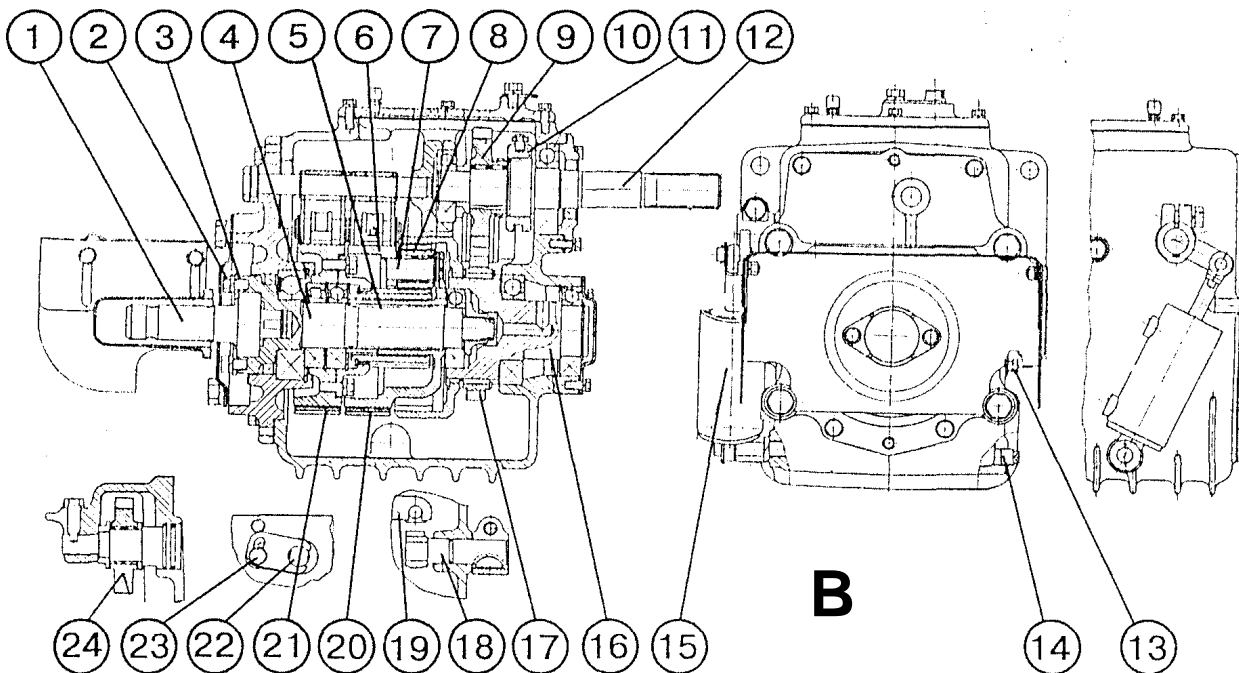

Construction and Operation of the FPTO

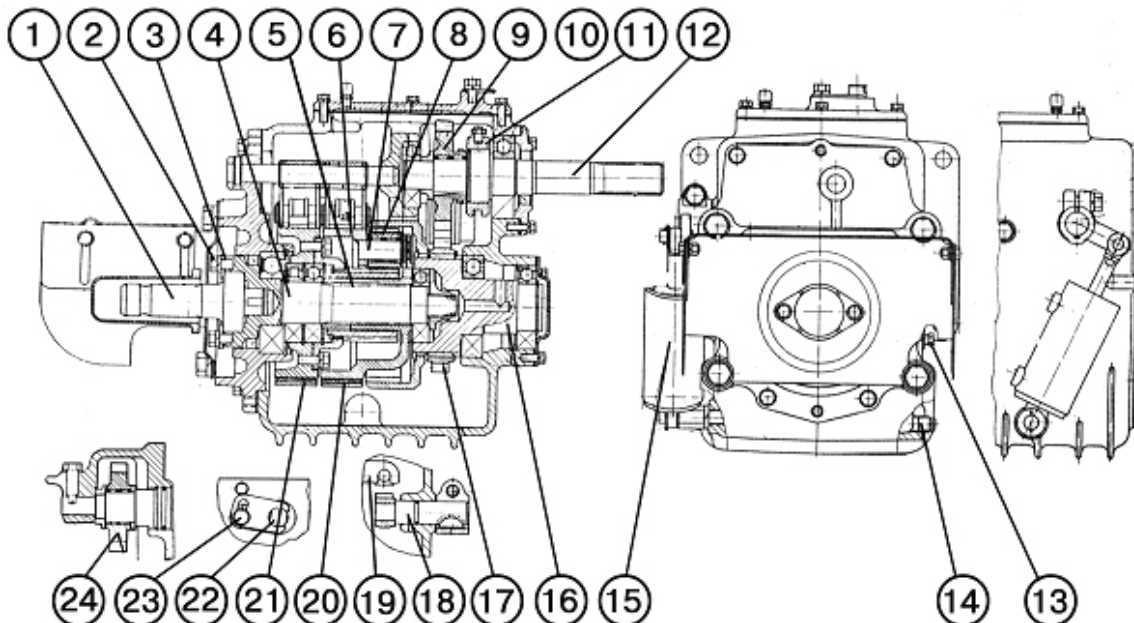

In the FPTO reduction gear, the power flow is transmitted from shaft (12) to the tail-piece (1) through a changeover clutch (11), pinion (10), intermediate gear (24), installed on shaft (12) and gear (17) installed on the shaft (16), the latter being in mesh with crown gear (9) of the planetary reduction gear.

The FPTO planetary reduction gear is unified with the rear PTO reduction gear on tractors MTZ-80. It is operated by a hydraulic cylinder (15) connected with the turning axle (18) which actuates the levers (19) of the band brakes.

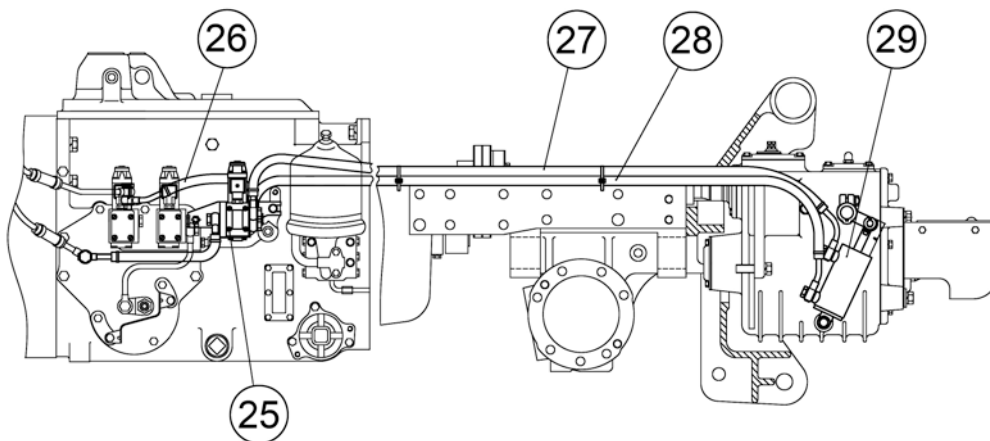

The displacement of the rod of the hydraulic cylinder (29) is provided by changing the direction of oil flow through the electrohydraulic distributor (25). The oil flow delivered through the pressure pipeline (26) is directed either into the pipeline (27) coupled with the rod

chamber of the cylinder (29) (the FPTO is disengaged when the rod is drawn in), or into the pipeline (28) coupled with the piston chamber of the cylinder (29) (FPTO is engaged when the rod is extended).

Front PTO Control

1. At minimum stable rotational speed of the engine, engage the FPTO; to do this, turn the lever (22) (see Figure “Construction and Operation of the FPTO”) located atop the reduction gear box counter-clockwise having loosened preliminarily the bolt (23). To disengage the drive, turn the lever (22) clockwise. The changeover completed, tighten the bolt (23).

2. To engage and disengage the FPTO, proceed as follows:

- to engage the FPTO, press down the lower half (which is closer to the operator) of the key (1) (see Figure below) up to the stop; then press down the button (3) and release it. Thereafter, the yellow warnings lamp (2) lights up to indicate that the FPTO is engaged;
- to disengage the FPTO, press down the upper half (which is farther from the operator) key (1), the warning lamp (2) goes out to indicate that the FPTO is disengaged.

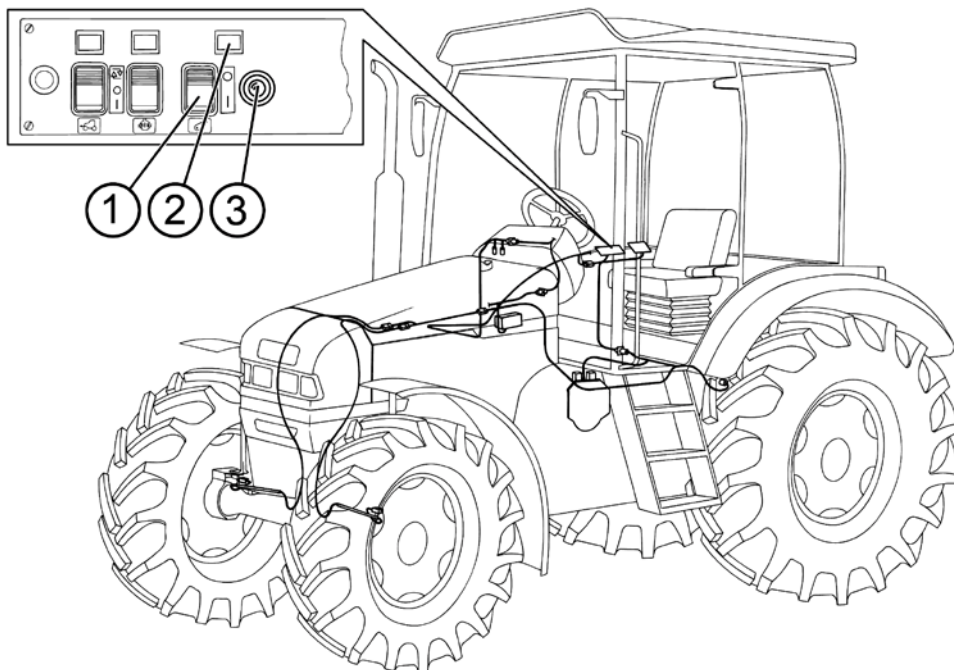

ATTENTION!

- If the FPTO is not to be used on mission, disengage the drive.
- Prior to cranking the engine for start-up, make sure that the key (1) and pushbutton (3) for engaging/disengaging the FPTO are in the “FPTO Disengaged” position (the warning lamp (2) is OFF).
- In case of accidental de-energizing of the control system (the alternator failing, driving belt rupture, etc.) disengage the drive to prevent premature damage to the FPTO reduction gear parts.
- On stopping the engine, the FPTO is disengaged automatically. To engage the FPTO after starting the engine, repeat the operations for engaging the FPTO.

3. The FPTO should be engaged with the engine idling; increase the engine speed to the required only after the agricultural machine has been speeded up.
4. To change the tail-piece (1) (see Figure "Construction and Operation of the FPTO") disengage the FPTO, stop the engine, unscrew six bolts (3), remove the plate (2), take out the tail-piece (1) and install the required one having applied preliminarily a thin layer of grease on the centring surface. To re-assemble, repeat the above operations in the reverse order.
5. When changing oil in the reduction gear, the new oil shall be filled to the level of the check plug (13).
6. Check regularly the extension of the control cylinder rod (dimension "A" (see Figure "Front PTO")). If the extension of the rod is less than 45 mm in the position "FPTO Disengaged" or more than 90 mm in the position "FPTO Engaged", replace the linings of the belt brakes (20, 21) (see Figure "Construction and Operation of the FPTO") of the planetary reduction gear.

FRONT DRIVING AXLE (FDA)

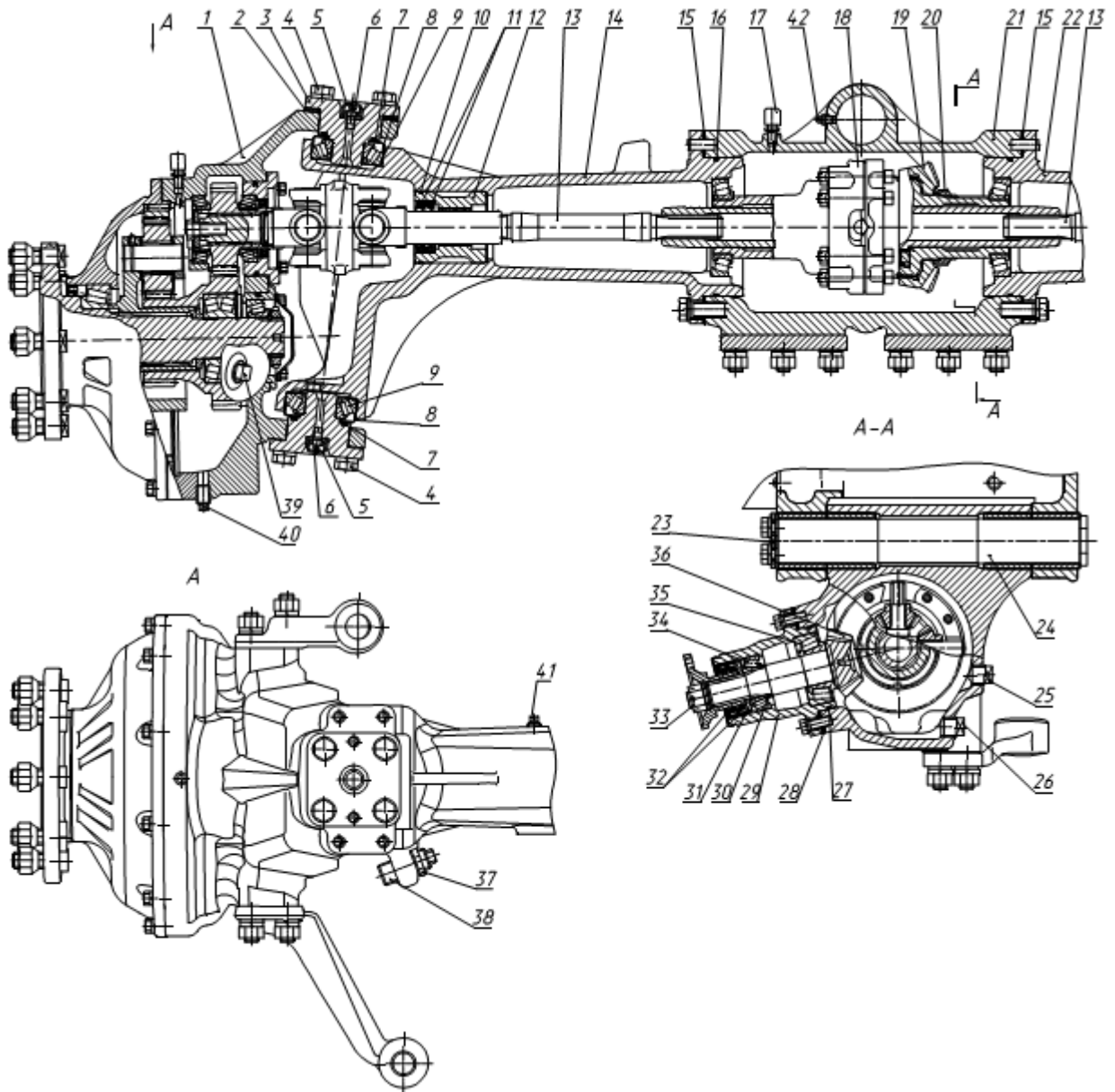

1 – driven bevel gear; 2, 15, 28 – adjusting shims; 3 – steering knuckle pivot spindle; 4 – bolt; 5 – cap; 6 – lubricator; 7, 10, 16, 27 – rubber ring; 8 – sleeve; 9, 34, 35 – taper roller bearing; 11, 32 – collar; 12 – fixture; 13 – half-axle shaft; 14 – left-hand housing; 17 – breather; 18 – differential; 19 – driven bevel gear; 20 – nut; 21 – FDA casing; 22 – right-hand housing; 23 – washer; 24 – pivot; 25 – plug; 26 – draining plug; 29 – driving gear carriage; 30 – adjusting washers; 31 – wiper ring; 33 – nut; 36 – driving bevel gear; 37 – locknut; 38 – screw; 39 – filling plug; 40 – draining plug, 41 – filling plug, 42 – lubricator.

The front driving axle (FDA) is intended for transmitting the torque from the engine to the front steerable wheels of the tractor. It consists of the final drive, differential and wheel reduction gears.

The left-hand (14) and right-hand (22) housings connected with the FDA cas-

ing (21) by means of bolts form the front axle beam. The FDA casing is provided with a breather (17) maintaining the normal pressure in the cavity of the axle and final drive beam.

The axle beam is filled with oil to the lower edge of the filling opening through the plugs (41) installed in the housings

(14) and (22). To drain oil from the axle beam, screw out the draining plug (26) located in the FDA casing. Oil shall be fed through the opening in one of housings until the lubricant in another housing reach the lower edge of the filling opening. The FDA shall be filled with oil on a horizontal surface.

The FDA casing (21) is connected with the beam by means of the pivot (24), on which the axle with the wheels can swing in the cross plane while deflecting to the angles limited by the stops of the ribs in the housings (14) and (22) when they contact the tractor beam. The pivot is locked against axial displacement by means of the washer (23). The pivot is greased through the lubricator (42).

Final Drive

The final drive is a pair of bevel helical gears.

The driving gear (36) of the final drive is mounted in the carriage (29) on two taper roller bearings. The tightness in the bearings is adjusted by means of adjusting washers (30), after which they are tightened by means of the nut (33). The driven gear (19) is fitted on the splines and centring spigot of the differential casing (18) and locked against axial displacement by means of the nut (20).

The final drive mesh is adjusted by means of the adjusting shims (28), (15) placed between the flange of the driving gear carriage and FDA casing as well as between the left- and right-hand housings and FDA casing, respectively. Before adjusting the mesh, the differential bearings shall be adjusted by means of the shims (15).

The opening for the plug (25) serves for checking the adjustment of the final drive mesh.

Oil leakage from the cavity of the final drive and axle beam is prevented by using the collars and rubber rings placed in the fixtures, housings and driving gear carrier.

To prevent the oil upthrust upstream the collar of the driving gear, the latter's splined end is fitted with the wiper ring (31) with spiral groves cut over the outer diameter of the ring. A slide bearing with crossed grooves is mounted in the fixture (12).

Differential

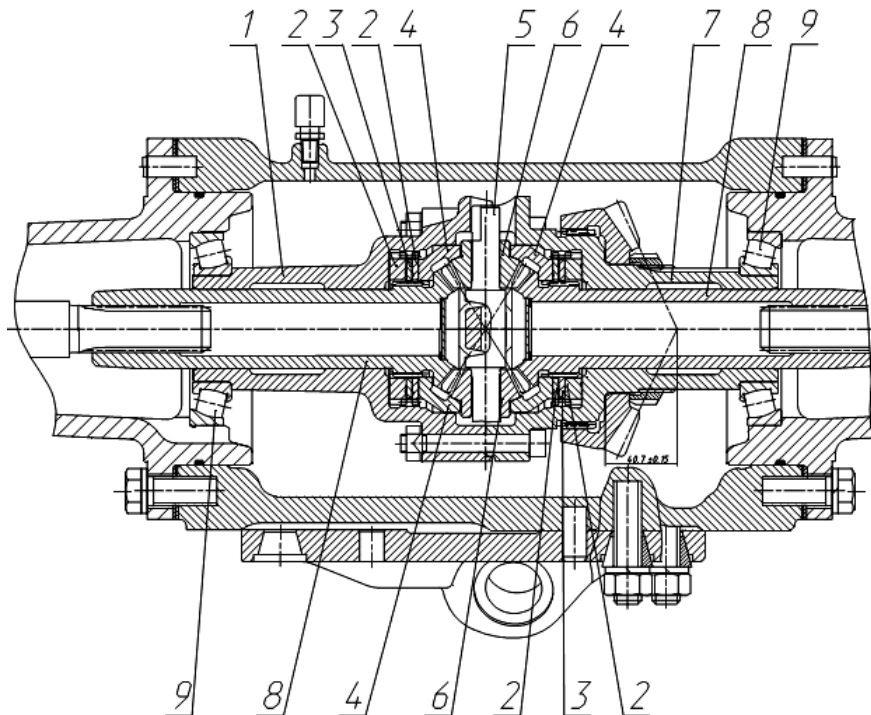

1 – differential casing; 2 – driving plate; 3 – driven plate; 4 – pressure cup; 5 – satellite shaft; 6 – satellite; 7 – differential cover; 8 – axle-shaft gear; 9 - taper roller bearing.

The differential is self-locking, with increased friction. The casing (1) and cover (7) of the differential bolted together contain the two pairs of satellites (6) on floating pins (5), axle-shaft gears (8), pressure cups (4) as well as driving (2) and driven (3) friction disks.

The self-locking differential connects automatically both the axle shafts and excludes separate skidding of the wheels that increases the tractive force of the front wheels. The locking takes place when the front axle is engaged. At that moment, the satellite shafts turn under load and move over the bevel slots in the casing and cover of the differential, respectively, by the value of the clearances between the friction disks. From the pins, the force is transmitted to the satellites which, in turn, transmit it through their beads to the cups, and the latter press the friction

disks against one another until they rest against the walls of the casing and cover of the differential. The driving plates having the outer teeth are in mesh with the teeth of the casing and cover of the differential and the driven plates (through their inner teeth) – with the axle shaft gears. The friction force of the pressed together disks unites the axle-shaft gears and casing with the cover of the differential into a whole while locking in such a way the differential.

When the front axle is engaged and the external forces exceed the friction forces in the friction disks during the turning of the tractor, the friction disks will skid.

The differential is installed in the two taper roller bearings in the housings of the front axle beam. The bearings of the differential are adjusted by means of the shims 15 (see Figure “FDA”).

Wheel reduction gears

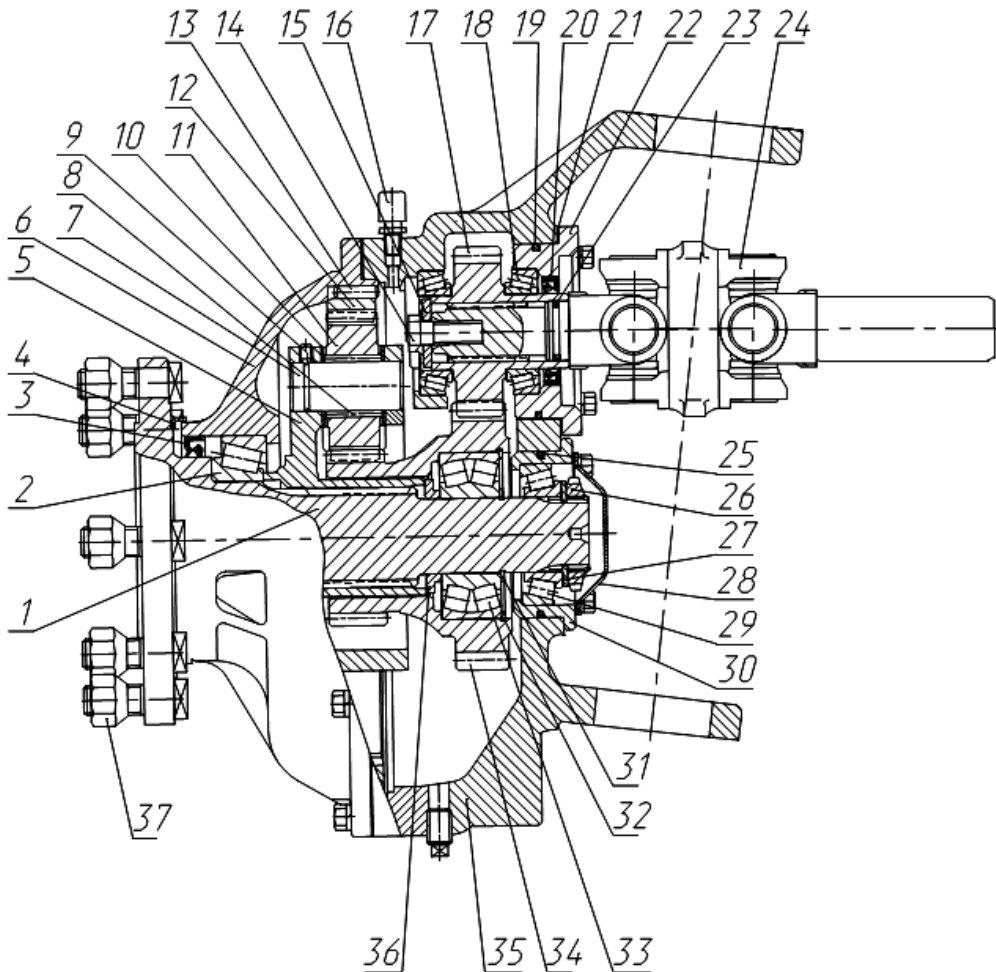

1 – wheel flange; 2, 18, 29 – taper roller bearing; 3, 20 – collars; 4 – mud trap; 5 – cage, 6 – reduction gear cover; 7 – satellite shaft; 8 – rollers; 9 – screw; 10 – thrust washer; 11 – satellite; 12 – epicyclic gear; 13 – pin; 14 – bolt; 15 – washer; 16 – breather; 17 – driving pinion; 19, 23, 25 – rubber ring; 21 – adjusting shims; 22 – driving pinion carrier; 24 – doubled universal joint; 26 – nut; 27 – washer; 28 – cover; 30 – carrier; 31, 32 – locking ring; 33 – two-row taper roller bearing; 34 – gear block; 35 – reduction gear casing; 36 – ring; 37 – wheel nut.

The wheel reduction gears of planetary spur-gear type are intended for transmitting and increasing the torque from the FDA differential at various angles of turning of the front steerable driving wheels.

The reduction gears are mounted in the casings (35) and connected with the axle beam by means of spindles (3) (see Figure “FDA”) and can turn relatively to the FDA beam on the two bearings (9). The spindles are connected with the wheel reduction gear casing by means of the bolts (4). The screw (38) and

locknut (37) serve for adjusting the angle of turn of the wheel reduction gears.

The pivots (3) are lubricated through lubricators (6) mounted on the pivots. The lubricators are protected against penetration of dirt by means of rubber caps (5). To protect the pivot bearings from dirt, the sleeves (8) with sealing rubber rings (7) are installed in the housings of the axle beam. The pivot bearings (9) are adjusted by means of the shims (2) located under upper spindles (3).

The wheel reduction gear (1) consists of a doubled joint, spur-gear and planetary drives, levers for controlling the turning of the front wheels.

The doubled universal joint (24) (see Figure "Wheel reduction gears") is connected with the FDA differential by means of half-axle shaft with splined ends (13) (see Figure "FDA") from the one side and with the driving gear (17) from the other side (see Figure "Wheel reduction gears") of the spur-gear drive.

The driving gear is mounted on the two taper roller bearings (18). One of them is installed in the counterbore of the reduction gear casing (35) and another – in the carrier (22). The doubled universal joint is fixed in the pinion by means of the washer (15) and bolt (14) with a bent-out plate.

The bearings (18) are adjusted by means of the shims (21) which are placed between the carrier and the reduction gear casing.

The driving gear of the wheel reduction gear is in mesh with the rear block (driven gear of the spur-gear drive) (34) the second crown of which is a sun gear or driving part of the planetary series. The driven part of the planetary series connected with the tractor wheel is the wheel flange which is spline-connected rigidly with the cage (5) by means of three satellites (11), while the epicyclic gear (12) serves as a braked gear perceiving the reactionary torque.

The epicyclic gear is mounted in the reduction gear and fixed against turning by three pins (13). An additional gasket is placed between the cover and casing of the reduction gear. The sun gear is mounted on the wheel flange, on the two-row taper bearing (33) which is fixed from the one side by means of the thrust ring (36) being in contact with the cage and from the other side – by means of two locking rings (31, 32).

The satellites rotate on the shafts (7) mounted in the counterbores of the cage

(5). The cylindrical rollers (8) serve as satellite bearings. One race of the rollers is the ground surface of the shaft (7) and another is the ground internal surface of the satellite (11).

The satellites and rollers are kept from displacement in the axial direction by the washers (10). The force fit in the connection of the cage with the shaft is used for keeping the satellite shafts from the axial displacement. The screw (9) turned into the groove of the shafts serves for checking the correctness of the press-fitting and additional fixation.

The wheel flange is mounted in the two roller bearings. One of them is mounted in the reduction gear cover (6) and the other – in the carrier (30) which is installed in the counterbore of the reduction gear casing, closed by means of the cover (28) and fastened to it by means of the bolts. An additional gasket is inserted between the carrier and the cover.

The bearings are adjusted by tightening the nut (26). The washer (27) is placed between the bearing (29) and the nut (26). To prevent the nut from turning out, the nut shoulder is punched in the slot of the wheel flange.

The reduction gear casing shall be filled with oil to the lower edge of the filling hole, into which the plug (39) is inserted (see Figure "FDA"). To drain oil, unscrew the draining plug (40).

The internal cavity of the wheel reduction gear is sealed by means of the collars (3) (see Figure "Wheel reduction gears") and (20). The mud trap (4) is installed for preventing the penetration of mud to the working edges of the collar (3). The counterbores of the steering knuckle and splines of the doubled universal joint shall be sealed by means of rubber rings (19, 23, 25). For maintaining the normal pressure in the reduction gear cavities, the reduction gear casing is provided with a breather (16).

FDA drive

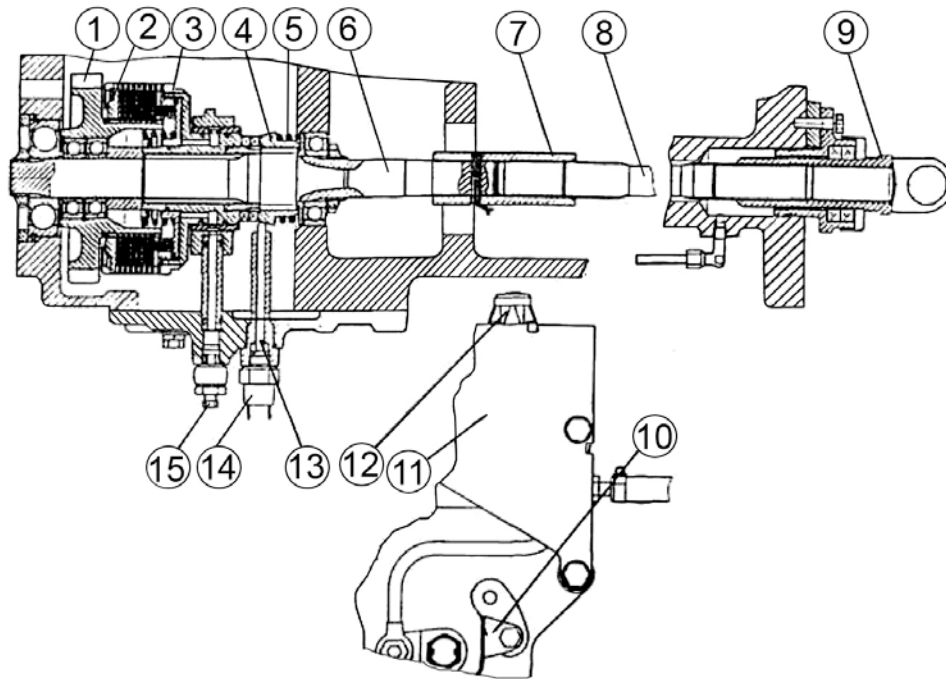

1 – gear; 2 – piston; 3 – drum; 4 – jaw semi-clutch; 5 – spring; 6 – shaft; 7 – splined bushing; 8 – torsion bar; 9 – universal-joint fork; 10 – clamp; 11 – protective shield; 12 – electrohydraulic distributor; 13 – pusher; 14 – switch; 15 – plug.

The FDA drive is intended for transmitting the torque from the gearbox secondary shaft to the front driving axle through synchronous PTO drive gear, multidisk hydraulically-controlled friction clutch, torsion bar and universal-joint shaft.

The FDA drive is engaged (disengaged) with the help of a hydraulic compression clutch, on a signal from the sensor. The latter is acted upon by a free-wheeling mechanism, depending on slipping of the rear wheels.

The FDA drive is located in the gearbox housing, on the right-hand side (as seen in the direction of tractor forward travel); the torsion bar passes through the clutch housing. The universal-shaft sliding fork support is installed in the clutch housing.

The drive consists of the following main units and parts. The shaft (6) is supported on the ball bearings in the GB housing. The gear (1) is free to rotate (when

the clutch is disengaged) on the shaft and is in constant mesh with the synchronous FDA drive gear; when the clutch is engaged, the gear comes in mesh with drum (3) of the hydraulic compression clutch through a pack of friction disks. The disks are cramped by the piston (2) under the action of oil pressure. The drum and the jaw semi-clutch (4) of the free-wheeling mechanism are splined on the shaft (6); the joint allows the drum to pivot through 45 degrees relative to the shaft. The semi-clutch is constantly pressed against the drum cams by spring (5) and are free to be displaced in the axial direction, thus, activating the pusher (13) of the drive automatic engagement sensor. The torsion bar (8) connects the shaft (6) to the universal-joint shaft sliding fork (9) through a splined bushing (7).

FDA Drive Operation

When the tractor is running straight ahead without any slipping, the shaft (6) (see Figure "FDA drive") connected with the FDA wheels rotates at the speed exceeding that of the gear (1) and the drum (3) rotates relatively to the shaft. The cams of the drum (3) move the semi-clutch (4) over the shaft splines in axial direction; thus, forcing the spring (5) to contract. When it will be done, the contacts of the switch (14) of the drive automatic engagement sensor are open and the electromagnet of the hydraulic distributor (12) is de-energized; there is no pressure in the friction clutch booster.

When the rear wheels start to skid in excess of a certain setting, the rotational speed of the shaft (6) drops so that the drum (3) turns through in the opposite direction and the spring (5) returns the semi-clutch (4) to its initial position. The semi-clutch moves the pusher (13) by its tapered part; the switch (14) closes the

circuit of the electromagnet of the distributor (12). Oil under pressure is fed to the clutch booster and forces the piston (2) to move. Due to this, the pack of disks is compressed and locks the gear (1) with the drum (3) to provide for direct transfer of the torque.

In case of forced engagement of the FDA, oil is fed to the clutch booster regardless of the rear wheel skidding. When the FDA is disengaged, the distributor shuts off the pressure channel and oil from the clutch booster is directed to drainage pipeline.

A general idea on design and operation modes of the FDA drive control system is described as a whole below.

To check pressure in the drive clutch booster, a diagnostic opening is provided which is stopped with a plug (15). The switch (14) and the electrohydraulic distributor (12) are protected with cramp (10) and shield (11).

Universal-Joint Shaft

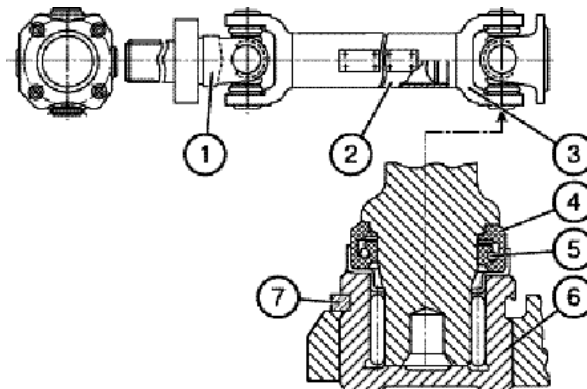

1, 3 – universal joints; 2 – universal-joint shaft tube; 4 – edge-joint packing; 5 – collar; 6 – needle bearing; 7 – retaining ring.

The universal-joint shaft is intended for transmitting the torque from the GB to the FDA.

The universal-joint shaft consists of a tube (2) and two universal joints (1), (3) with the universal-joint trunnions running in needle bearings (6). The needle bearing cages are locked with retaining rings

(7); the bearing journals of the trunnion cross are provided with edge-joint packings (4) and self-tightening collars (5).

The universal-joint shaft in assembly is dynamically balanced.

To ensure against winding of straw-stemmed crops on the universal-joint

shaft when harvesting, a special enclosure is provided.

FDA Drive Control System

The system includes a panel (1), sensor of angle of the steerable wheel turn (11) (if installed) located on the gearbox on the left-hand side, two service brake application sensors (13), sensor (7) of the FDA drive automatic engagement, electrohydraulic distributor (8) located on the gearbox cover on the right, electric cables (9), connector socket (4) and terminal blocks (12).

The system is energized in a manner similar to the above described system of the rear axle differential interlock.

The automatic engagement sensor (7) consists of a pusher (13) (see Figure "FDA drive"), guide and switch (14).

The key-switch (15) (see Figure below) for controlling the FDA drive and warning lamp (14) of the engaged state of the drive are located on the panel (1).

The switch (15) has three positions:

- "Automatic FDA Control" (top fixed position);
- "FDA Force Engaged" (lower fixed position);
- "FDA Disengaged" (middle fixed position).

With the switch (15) set to the "FDA Disengaged" position, the electrohydraulic distributor (8) is de-energized, the FDA drive clutch communicates with the drain line, and the FDA drive is disengaged.

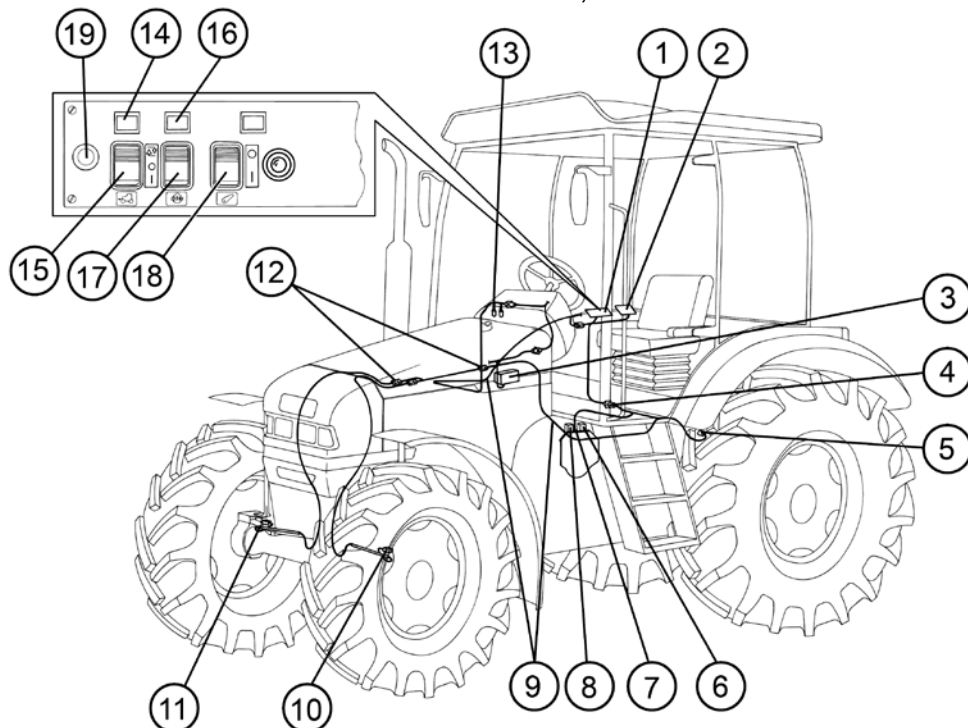

Rear axle differential lock (DL) and the front driving axle (FDA) drive control system:

1 – control panel; 2 – safety fuse block; 3 – engagement relay block; 4 – cable connector assembly; 5 – reverse sensor; 6 – DL control hydraulic distributor, 7 – FDA drive automatic engagement sensor; 8 – FDA drive control hydraulic distributor; 9 – connecting cables; 10, 11 – driving wheels angle-of-turn sensors; +13 degrees and +25 degrees, respectively; 12 – terminal blocks; 13 – service brake application sensors; 14, 16, 20 – warning lights; 15 – FDA drive control selector switch; 17 – DL control selector switch; 18 – FPTO switch (if installed); 19 – horn switch (1523B)

With the switch (15) in the "FDA Automatic Control" position, the FDA drive operates automatically, when the tractor runs forward, due to the sensor (7)

whose engagement signal is fed to the solenoid of the electrohydraulic distributor (8) depending on wheel slipping. The latter directs oil flow under pressure to

the FDA drive clutch. The FDA drive is automatically disengaged when the front wheels angle of turn exceeds 25° irrespective of the direction. A disengagement signal arrives from sensor (11).

When the switch (15) is set to the “FDA Forced Engagement” position, the FDA drive is engaged forcibly both in forward and in reverse, regardless of the front wheels angle of turn and/or slippage.

ATTENTION!

- When interlocked brake pedals are stepped on, the FDA drive is en-

gaged irrespective of the switch (15) position.

- When running on hard-surface roads, BE SURE TO DISENGAGE THE FDA (switch (15) in its middle position) to avoid excessive wear of front wheel tyres as well as of drive components may occur.
- With the tractor operated in reverse, use the FDA forced engagement mode only. NEVER engage the FDA forcibly at the tractor speeds exceeding 15 km/h.

Adjusting the ЭВИТ-C3 Sensors of the Angle of Turn of the Steerable Wheels

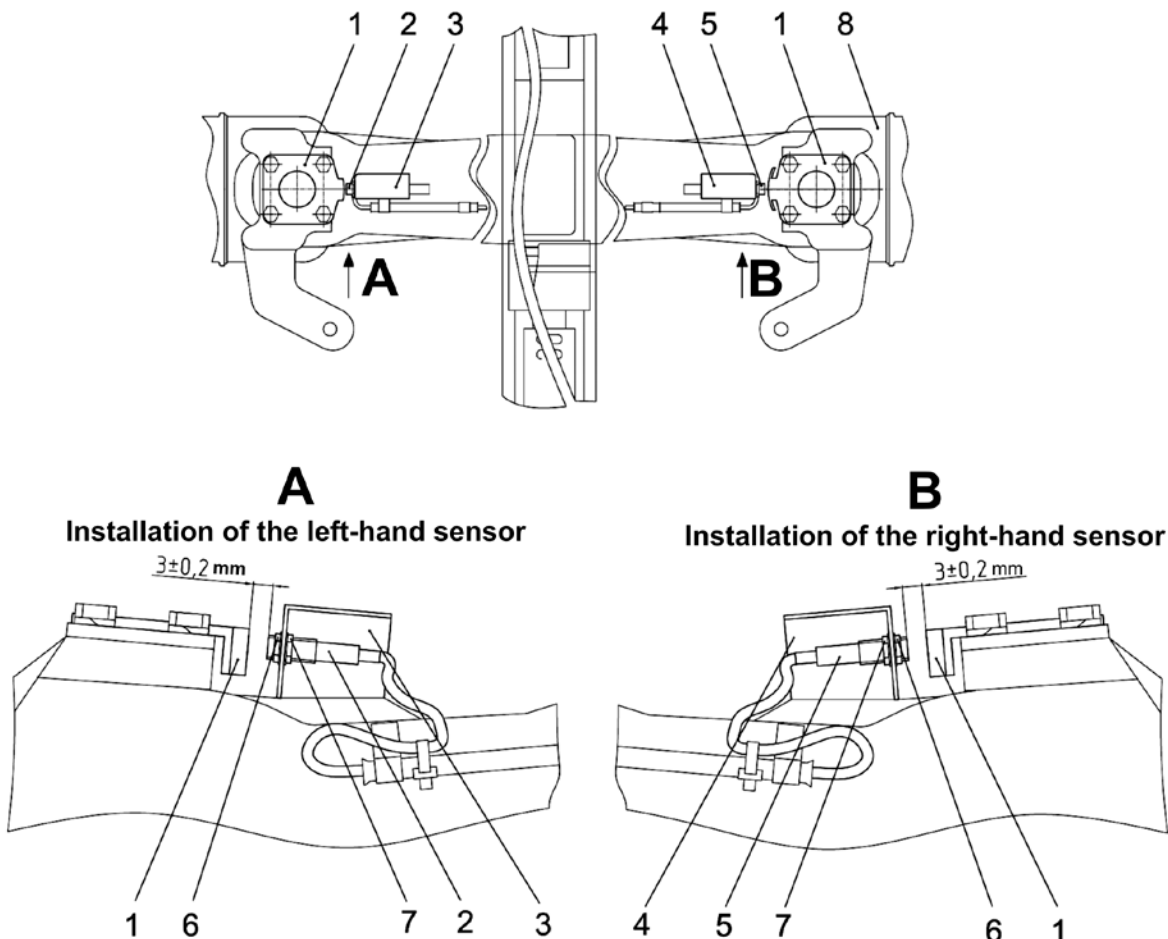

1, 3, 4 – brackets; 2 – turn angle sensor (±13°, DL); 5 – turn angle sensor (±25°, FDA); 6 – outer nut; 7 – inner nut; 8 – front axle (top view).

Adjusting the FDA Drive Automatic Engagement Sensor Switch

Adjust the switch (5) when the assembly of the hydraulic compression clutch is completed and the cover (6) is refitted to the transmission. To do this, proceed as follows:

1. Turn the drum (1) and set it to the position I, when the cams of the semi-clutch (2) and those of the drum (1) are completely brought together, and the pusher (3) is drawn out to its extreme position.
2. Place the original number of the adjusting shims (4) (5-6 pieces) under the end-face of the switch (5).
3. Try to attain position II of the switch (5), when its contacts are closed by removing the adjusting shims (4) one by one.
4. Place the semi-clutch (2) to position II, wherein cams of the semi-clutch (2) and the drum (1) are completely separated and the pusher (3) is depressed to its extreme position.
5. Check whether contacts of the switch (5) are open in position II.

Failure to meet this requirement can cause the failure of the switch (5).

The switch is considered to be correctly adjusted if its contacts are closed in the position I, while in the position II they are opened. The check shall be carried out in accordance with indications of the warning lamp. It is allowable to check against the warning light on the control panel; in this case the FDA drive control key should be in its upper position.

Note:

When in position I, the dimension A between the end-face of the pusher (3) and the end-face of the switch (5) should be at least 1.5 mm.

Position I (engaged)

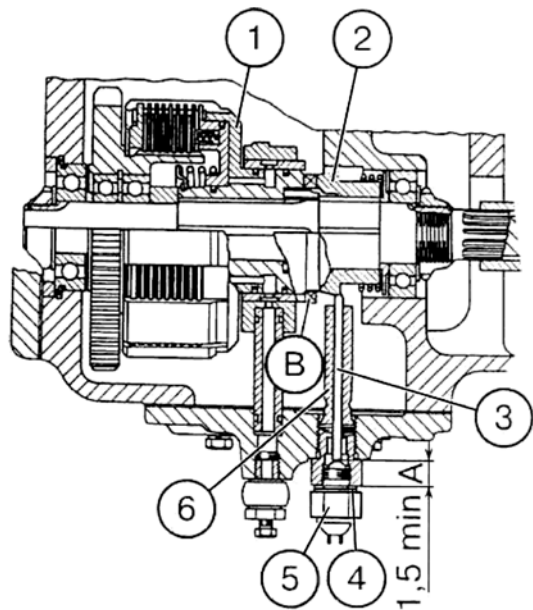

1 – drum; 2 – semi-clutch; 3 – pusher; 4 – shim; 5 – switch; 6 – cover.

Position II (engaged)

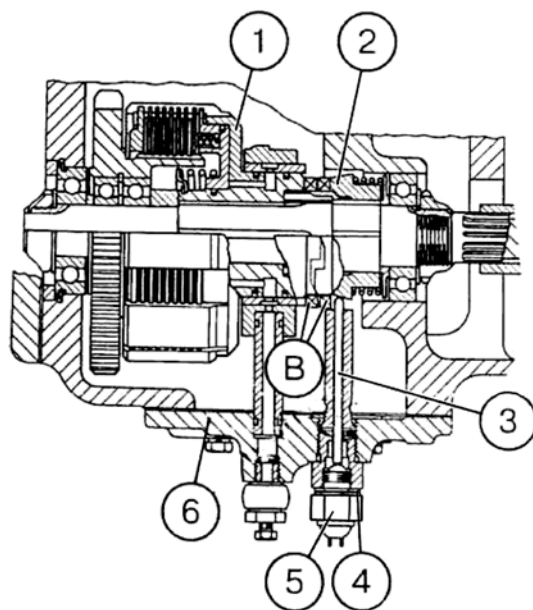

BRAKES

These tractors are equipped with left- and right-hand service brakes actuated by means of the pedals (5, 6) parking brake with an independent mechanical manual control by means of the handle (7) acting upon the service brakes.

The service brake actuator is a hydrostatic one to be operated by the left-hand (3) and right-hand (4) master

hydraulic brake cylinders and the left-hand (12) and right-hand (8) service cylinders.

The independent manual mechanical control of the brakes is exercised by means of the handle (7) through a linkage and leverage system.

Table 5-7

Brakes	Brake control	Brake drive	Type of brakes	Installed on
Service	Foot	Hydrostatic	Working in the oil bath ("wet")	1. Driving pinion shafts of the hub drives;
Parking	Manual	Mechanical, with independent drive to the service brakes	Working in the oil bath ("wet")	2. Splined end faces of the driving pinions of the final drives.

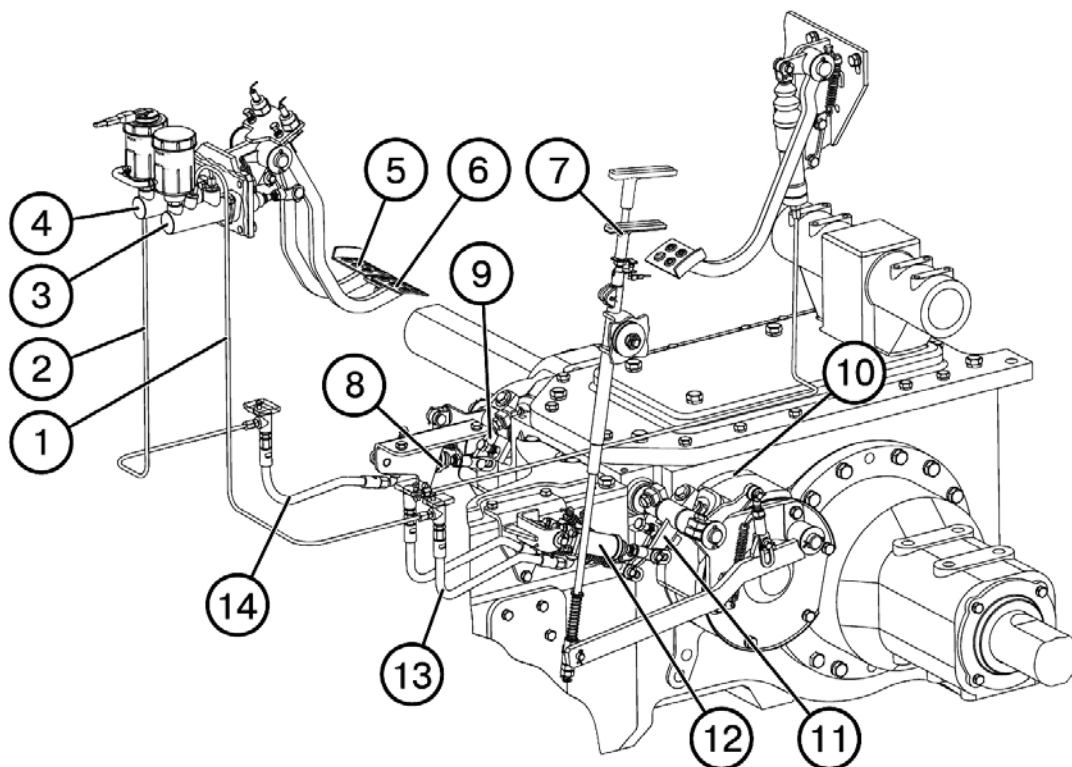

1, 2 – pipeline; 3, 4 – left- and right-hand master cylinder; 5, 6 – right- and left-hand brake pedal; 7 – parking brake handle; 8 – service brake of the right-hand brake; 9 – lever of the right-hand brake; 10 – carriage; 11 – lever of the left-hand brake; 12 – working cylinder of the left-hand brake; 13, 14 – connecting hose.

“Wet” Service Brakes

The service brakes are of 8-disk type. The friction disks (2) are installed in splined ends of the hub drive pinions (16). The pressure disks (6) are similar in design to those used in dry brakes, but with a reduced angle of gradient of pits for balls, to ensure the required force of compression of the packs of the friction and intermediate disks.

The intermediate disks (3) are fixed from turning in their cases (1, 13) by means of shoulders made over the outer profile. The leak-proofness of the oil baths is ensured by the O-rings (15, 24), gaskets (10, 14) and rubber boots (5, 23). The cases are provided with inspection (22) and drain (12) plugs.

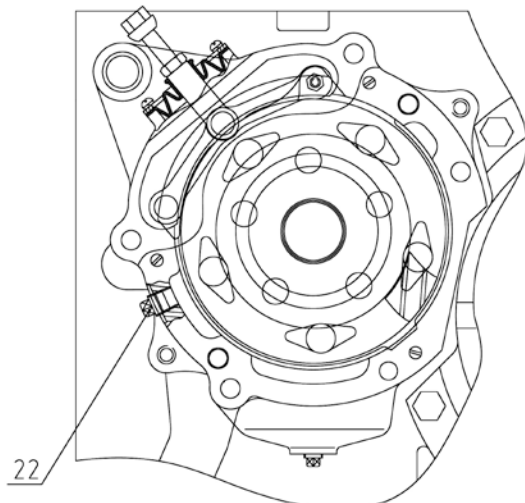
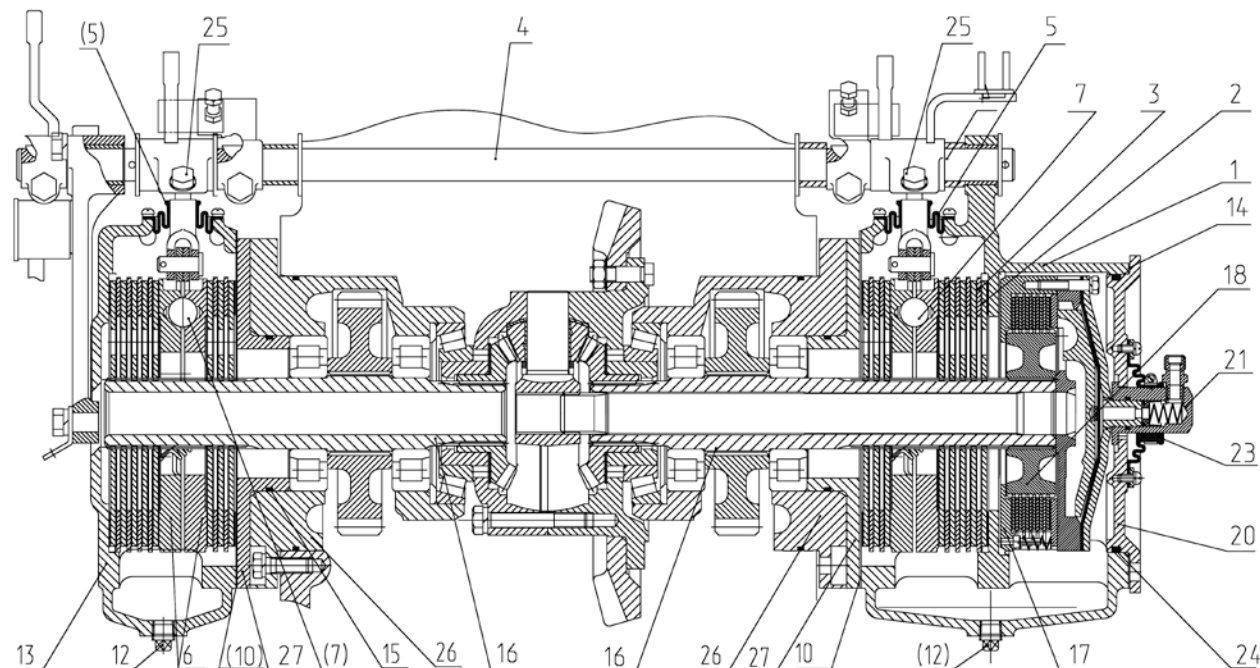

- 1 – brake casing; 2 – friction disk; 3 – intermediate disk; 4 – roller; 5 – sealing boot; 6 – pressure disk; 7 – ball; 10 – gasket; 12 – draining plug; 13 – brake casing; 14 – gasket; 15 – O-ring; 16 – final drive pinion; 17 – lock clutch; 18 – boss; 20 – cover; 21 – oil feeding adaptor; 22 – inspection and filler plug; 23 – sealing boot; 24 – O-ring; 25 – brake rod (adjusting bolt); 26 – carrier; 27 – carrier cover.

Parking Brake

The service brakes having a separate actuator from the control lever.

“Wet” Clutch for Locking Up the Differential

The lock-up clutch (17) comprises six disks with brake ceramic-metal linings fitted on the splined boss (18) connected with the hub drive pinion (16). A pack of six friction and five intermediate disks is compressed as oil under pressure is fed to the diaphragm space. The frictional torque developed thereby ensures interlocking of the rear axle differential. The clutch is made in a single case with the service brake. It shares a common oil bath with the brake and is sealed by means of the cover (20) and special corrugated boot (23) slipped over the adaptor (21) which delivers oil to the working space of the diaphragm.

“Wet” Brake Control

The service brakes control actuator is of hydrostatic type.

The parking brake control is mechanical.

Brake maintenance

“Wet” brake adjustment: pedal travel 100...120 mm under the force of (300±30) N applied to one pedal. It is adjusted by the bolts (25).

The oil level in the brake casings shall reach the edges of the holes of the inspection plugs (22) on the front walls of the casings. The oil in the brake casings shall be changed simultaneously with changing of oil in the transmission.

The mark of oil to be used for the brakes is similar to that of oil in the transmis-

sion. The draining plugs (12) located at the bottom are provided for draining oil from the brake casings. The oil level in the casings shall be checked after every 500 hours of operation of the tractor.

Attention! NEVER operate the tractor without oil or with insufficient oil level.

Hydraulic Brake Actuator of the BELARUS-1523/1523.3 Tractor

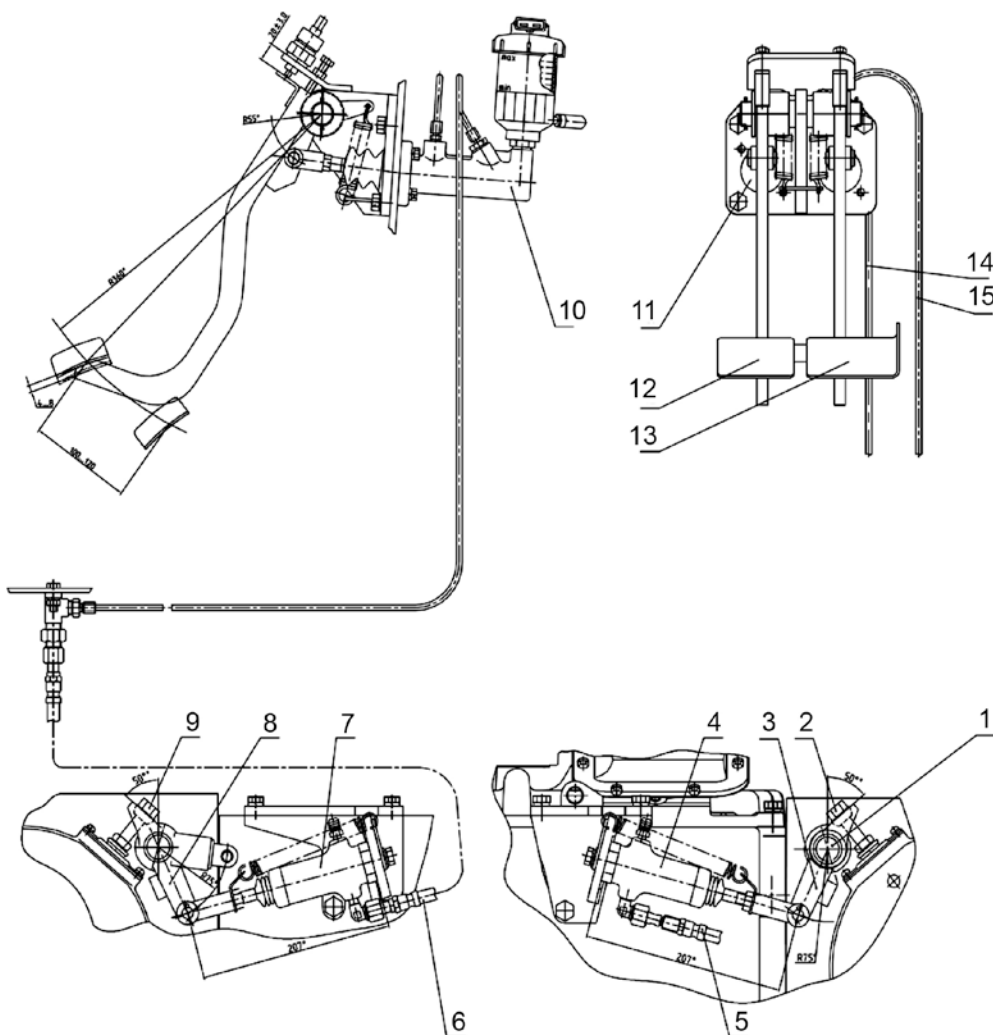

1 – brake roller; 2, 9 – link bolt; 3, 8 – levers of the left- and right-hand brake, respectively; 4, 7 – left- and right-hand service cylinder; 5, 6 – flexible hose of the brakes; 10, 11 – right- and left-hand master cylinders; 12, 13 – left- and right-hand brake pedals; 14, 15 – pipelines.

The hydraulic actuator of the tractor brakes provides for independent control of the service brakes by means of pedals (12, 13) and (10, 11) manufactured by the CARLISLE Company. The rods of the cylinders are connected pivotally with the brake pedals: of the left-hand service brake cylinder (4) connected with the left-hand master hydraulic cylinder (11) by means of the pipeline (14) and hose (5), and of the right-hand service brake cylinder (7) connected with the left-hand master hydraulic cylinder (10) by means of

the pipeline (15) and hose (6). The rods of the left-hand (4) and right-hand (7) service brake cylinders are connected pivotally with the levers (3, 8) of the left- and right-hand service brakes, respectively, and on stepping on the pedals (12, 13), they transmit the forces to:

- the left-hand service brake – through the lever (3) the link bolt (2);
- the right-hand service brake – through the lever (8) and link bolt (9).

Hydraulic Brake Actuator of the BELARUS-1523B/1523B.3 Tractor

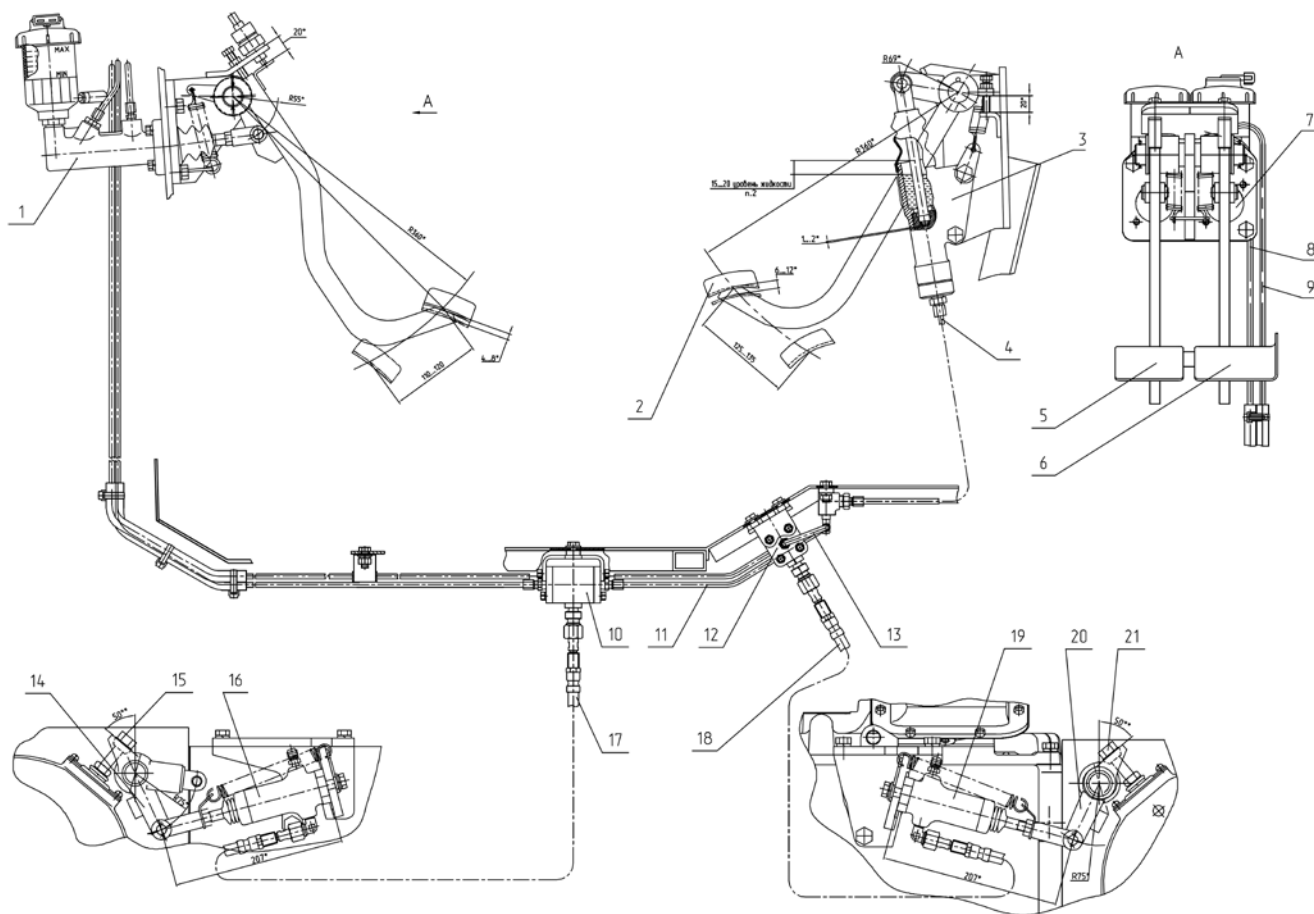

1,7 – right-hand master brake cylinder; 2 – reverse pedal; 3 – reverse master brake cylinder; 4, 8, 9, 11, 13 – pipeline; 5, 6 – left-hand brake pedal; 10, 12 – tap; 14, 20 – brake lever (right- and left-hand); 15, 21 – link bolt; 16; 19 – master brake cylinder (right- and left-hand).

The hydraulic actuator of the tractor brakes is intended for transmitting the force when braking during the forward and reverse motion from the work members (pedals) to the actuators (service brake cylinders) by means of the actuating medium (brake fluid). The brake actuation type is hydrostatic, with overhang pedals.

The actuator consists of the master cylinders (1, 7) (for forward motion) and (3) (for the reverse mode), overhang pedals (5, 6) (for forward motion) and (2) (for the reverse mode), taps (10, 12) (for automatic switching-over from the forward- to the reverse-motion mode of operation of the tractor and vice versa),

service brake cylinders (16, 19), levers (14, 20), bolts (15, 21), flexible hoses (17, 18) and pipelines (8, 9) (for forward motion) and (4, 11, 13) (for reverse).

When stepping on the pedals (5, 6) in the forward motion mode, the brake fluid is passed from the master cylinders (1, 7) through the pipelines (8, 9) into the taps (10, 12). In the taps, the pistons move to the extreme position and close the inlets of the pipelines (11, 13). Then the brake fluid is passed through the flexible hoses (17, 18) into the service cylinders (16, 19) and moves their pistons which act upon the levers (14, 20) by means of rods. The levers turn and pull

out the bolts (15, 21) acting upon the brakes.

When stepping on the pedal (2) in the reverse mode, the brake fluid from the master cylinder (3) is passed through the pipelines (4, 11, 13) into the taps (10, 12). In the taps, the pistons move to opposite positions and close the inlets of

the pipelines (8, 9). Then the brake fluid is passed through the flexible hoses (17, 18) into the service cylinders (16, 19) to act as described above.

The brake fluid "Neva-M", Technical Specification TY 2451-053-36732629-2003 is used as working fluid in the hydraulic brake actuator system.

Adjusting the Brakes

Adjusting the Service Brakes of the BELARUS-1523/1523.3 Tractors

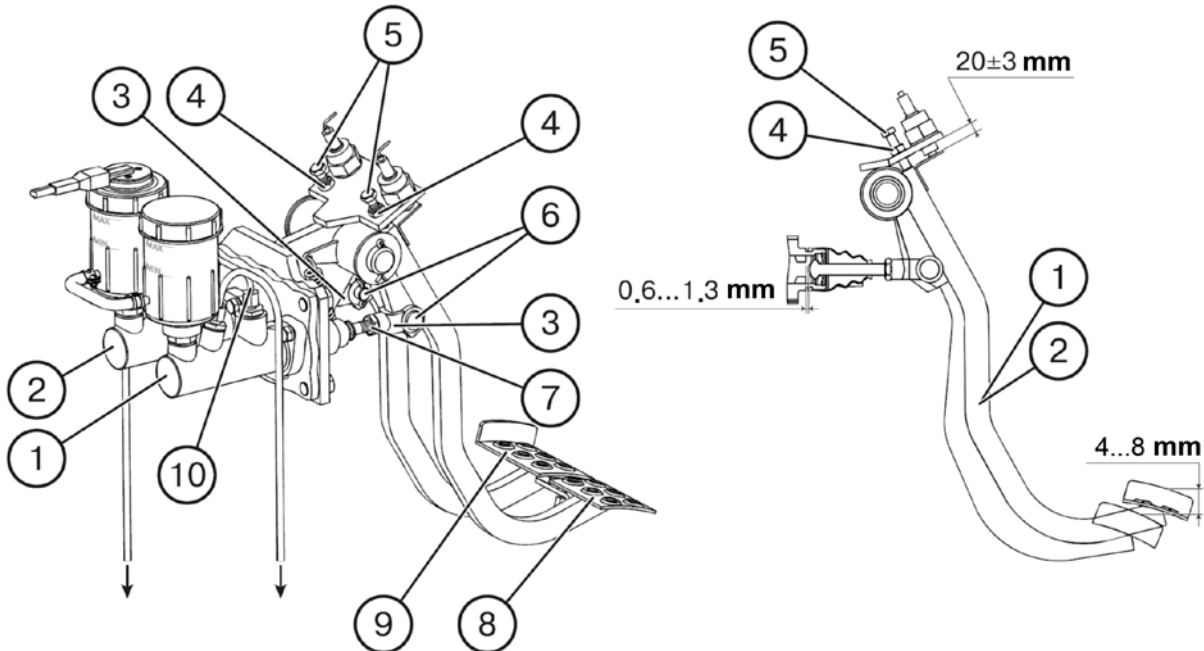

To adjust the service brakes of the tractors without reversible control post, proceed as follows:

1. Set the pedal pads (8, 9) in one plane making use of the thrust adjusting bolts (5) for the purpose by screwing them in to about 20 ± 3 mm. Lock the nuts (4).
2. Adjust the free play of the pedals (8, 9) to within 4...8 mm. To do this, proceed as follows:
 - 2.1. Uncotter and remove pins (6) and disconnect forks (3) from the stems of pedals (8, 9).
 - 2.2. Turn out the lock-nuts (7) several turns and, by screwing the forks (3) in or out, shorten or lengthen, respectively, the hydraulic cylinder (1, 2)

rods, to meet the required free play of the pedals.

- 2.3. Lock nuts (7) fitted on pins (6) and cotter-pin them. The pedal free play of 4...8 mm corresponds to a 0.6...1.3 mm clearance between the piston and the pusher in each master hydraulic cylinder.
- 2.4. The pedals should not be in contact with whatever components of the cab. The position of pedal pads as to height is be adjusted, if required, by bolts (5) and by changing the length of the hydraulic cylinder rods; provided the pedal free play is maintained within 4...8 mm.

3. Ensure the length of each service hydraulic cylinder (1, 14) to be (207 ± 2) mm, if measured from the cylinder attachment point to the axis of pin

which connects the levers (5, 9) with the forks (3, 12), respectively, with the piston of the working cylinder fully drawn in.

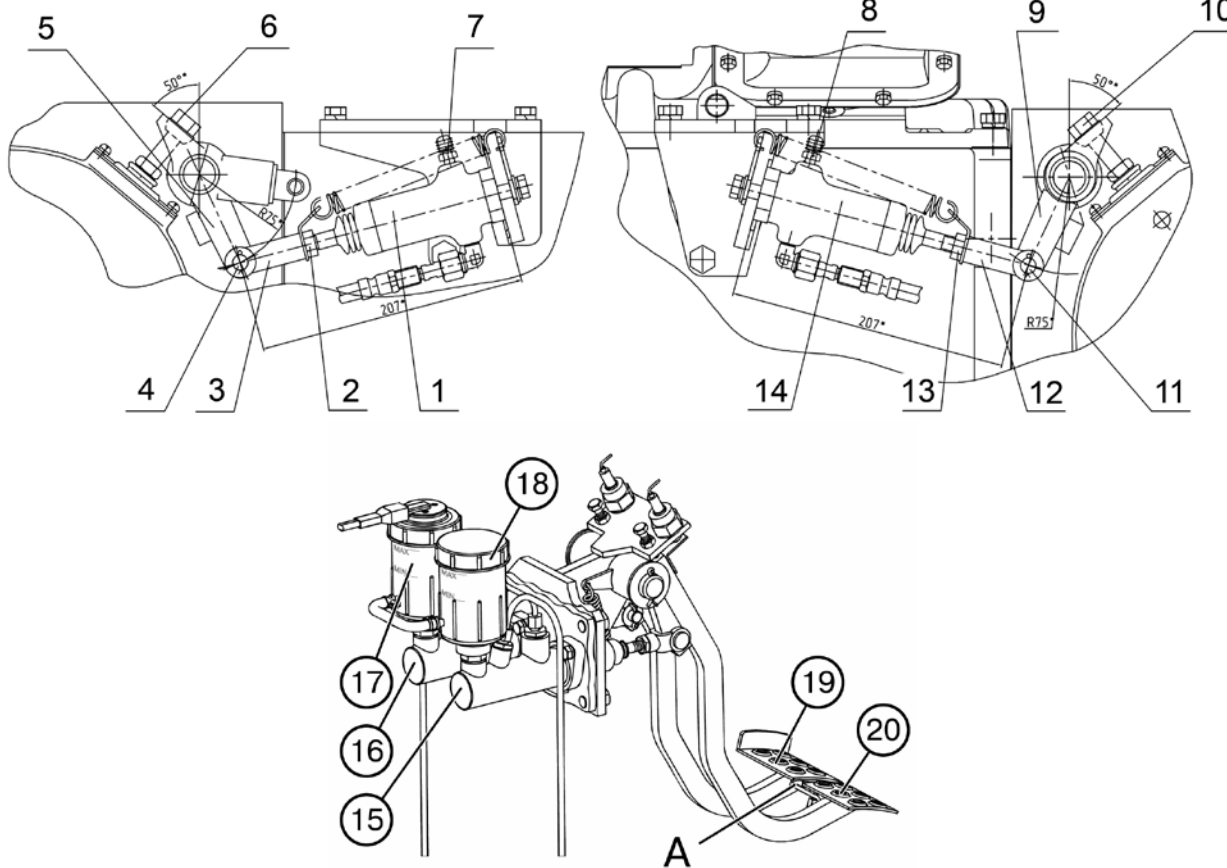

Carry out the adjustments by means of forks (3, 12), link bolts (6, 10) having performed the following operations:

- Loosen the locknuts (2, 13) by several turns.
- Uncotter and remove the pins (4, 11) having disconnected the forks (3, 12) from the levers (5, 9) of the right- and left-hand service brakes, respectively.
- Adjust the dimension 207 ± 2 mm by screwing the forks (3, 12) to or from the rods of the service brake cylinders (1, 14).
- Lock the locknuts (2, 13), insert the pins (4, 11) and fix them by cotter pins.

4. Fill the hydraulic drive system with brake fluid and bleed air from it; to do this, proceed as follows:

- Fill the reservoirs (17, 18) of the master brake cylinders (16, 15) with the "Neva-M" brake fluid, Technical Specifications TY 2451-053-36732629-2003, to the "Max" marks on the reservoirs (to the level of 15 ± 5 mm to the top of the reservoir). In the process of bleeding keep the fluid level from dropping below the "Min" mark.
- Latch the brake pedals (19, 20) with the interlocking strap "A".
- Clean the bypass valves (7, 8) from dust and dirt, remove the caps from them, fit a tube onto the head of the bypass valve of the left-hand working cylinder and put its free end into a

transparent vessel with the capacity of at least 0.5 l filled with brake fluid to half of its volume;

- Step on the interlocked brake pedals 4...5 times and, while holding them down, turn out the valve of the left-hand service cylinder by 1/2...3/4 turns. When, following a full pedal stroke, part of the fluid with air bubbles is bled from the system, turn the valve in and release the brake pedals. **Step on them quickly and release them smoothly!** Repeat this operation several times until air is bled completely from the system. Remove the tube from the valve and refit the protective cap.
- Bleed air from the hydraulic actuator of the right hand brake.
- Top up fluid in both reservoirs (17, 18) to the "Max" mark (10...20 mm from the top end-face of the reservoir); remove tubes from the valves and refit protective caps.

Check the full travel of unlatched pedals under a force of (300 ± 30) N applied. It shall be within 100...120 mm. If the full travel of the pedal falls outside these limits, readjust them proceeding as follows:

- Turn out the locknuts of the link bolts (6, 10) by several turns.
- Turn the adjusting link bolts (6, 10) of the right- and left-hand service brakes in or out.
- Lock the link bolts.

Check the efficiency of the service brakes with the tractor on move on a dry hard-surface road, with the clutch disengaged. With the latched pedals pressed down at 590...600 N, the stopping distance shall not exceed 6.4 m at a tractor speed of 20 km/h. The deviation of the tractor motion during the braking shall not exceed 0.5 m. If necessary, adjust simultaneity of the beginning of the braking using one of the adjusting link bolts (6) or (10).

Adjusting the Parking Brake Actuator

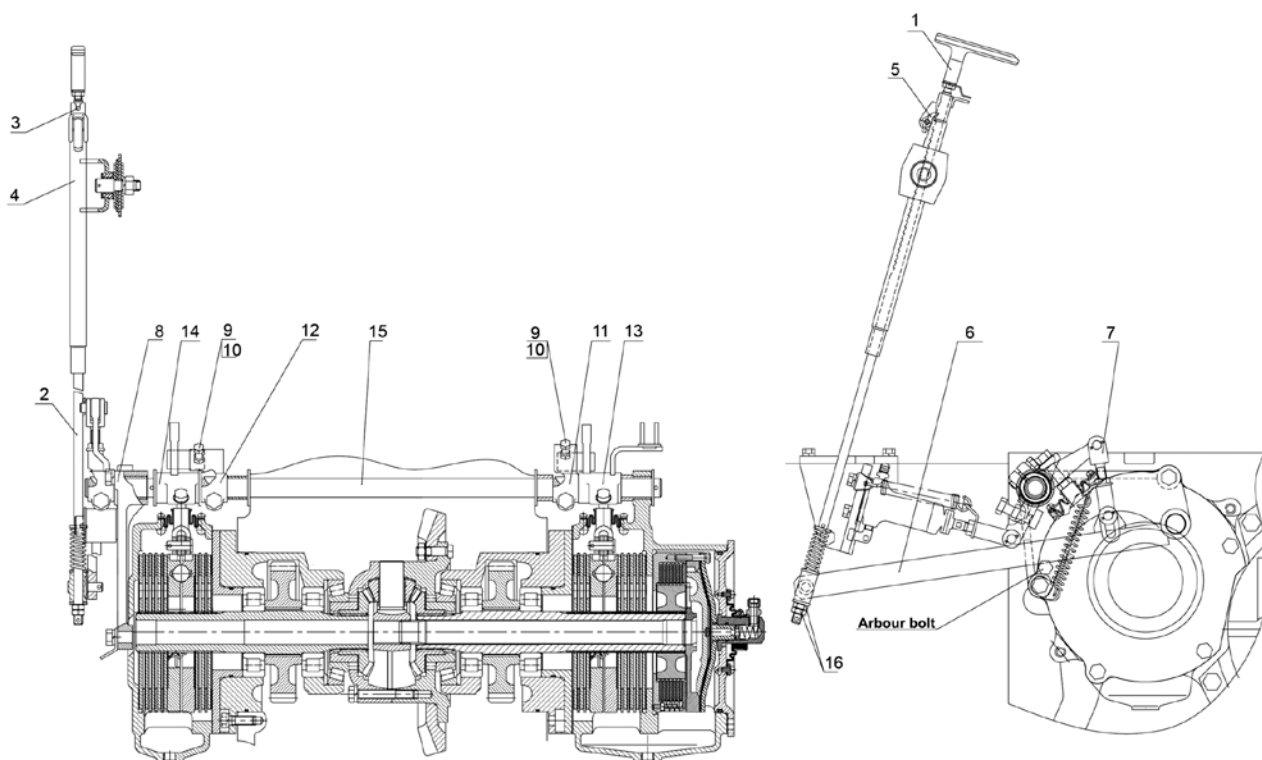

1 – handle; 2 – rod; 3 – pin; 4 – bracket; 5 – latch; 6 – lever; 7 – rod; 8 – bracket; 9 – locknut; 10 – adjusting bolt; 11, 13 – right-hand brake levers; 12, 14 – left-hand brake levers; 15 – roller; 16 – nuts.

Prior to adjusting the parking brake actuator, adjust the service brakes.

To adjust the control of the manual mechanical brake actuator (parking brake), proceed as follows:

1. Push the handle (1) with the rod (2) to the bottom (released) position. The locking finger (3) of the rod (2) shall be in the slot of the bracket (4) and the latch (5) – on the first tooth of the rod (2).
2. Disconnect the rod (2) from the lever (6).
3. Disconnect the rod (7) from the lever (6). Set the length of the rod (7) to (97 ± 1) mm. Connect the lever (6) with the rod (7).
4. Turn the fixture bolt into the mounting hole in the bracket (8).
5. Turn out the locknuts (9) of the bolts (10) of the right- and left-hand levers (11) and (12). Take up the clearance between the bolt (10) of the right-hand brake and plate of the lever (13) by turning the bolt (10); for the left-hand brake, set the clearance between the bolt (10) and the plate of the lever (14) to be (3...4) mm to compensate for screwing out the roller (15) when tightening the right-hand brake.
6. Lock the bolts (10) of the left- and right-hand brakes by means of the locknuts (9).
7. Connect the rod (2) with the lever (6) by turning the nuts (16) of the rod (2) until the lever (6) begins to come off the fixture bolt and lock the nuts between one another.

8. The final check and adjustment of the manual mechanical control of the brakes shall be performed on the assembled tractor. The tractor shall be held on the slope of at least 18 % on

applying the force not exceeding 400 N to the control handle (1).

If necessary, the adjustment shall be corrected by means of the bolts (10).

Adjusting the Service Brakes of the BELARUS-1523B/1523B.3 Tractors

IMPORTANT! Adjustment of the brakes should only be carried out after checking and adjusting the service brakes for forward motion and the parking brake.

The forward-motion brakes shall be adjusted and air shall be bled from them in the same way as described for the service brakes of the BELARUS-1523/1523.3 tractor.

In the reverse motion, the tractor brakes shall be adjusted as follows:

1. Check and, if necessary, adjust the dimension 33 ± 2 mm by screwing the thrust bolt (9) in to the specified depth. After the adjustment of the thrust bolt (9) is completed, tighten the lock-nut (8).
2. Adjust the free-play of pedal (1) to within 6...12 mm; this figure corresponds to a clearance of 1...2 mm between the push rod (4) of the master brake cylinder (3) and the piston (2). To adjust, follow with the procedures, as follows:
 - Uncotter and remove the pin (7).
 - Remove the protective boot and turn out the lock-nut (5) by several revolutions.
 - Set the free travel of the pedal (1) within the limits specified above by screwing the fork (6) on or from the push rod (4). The free travel of the pedal shall be 90...110 mm.
 - Lock the nut (5), fix the pin (7) with a cotter pin and refit the boot.

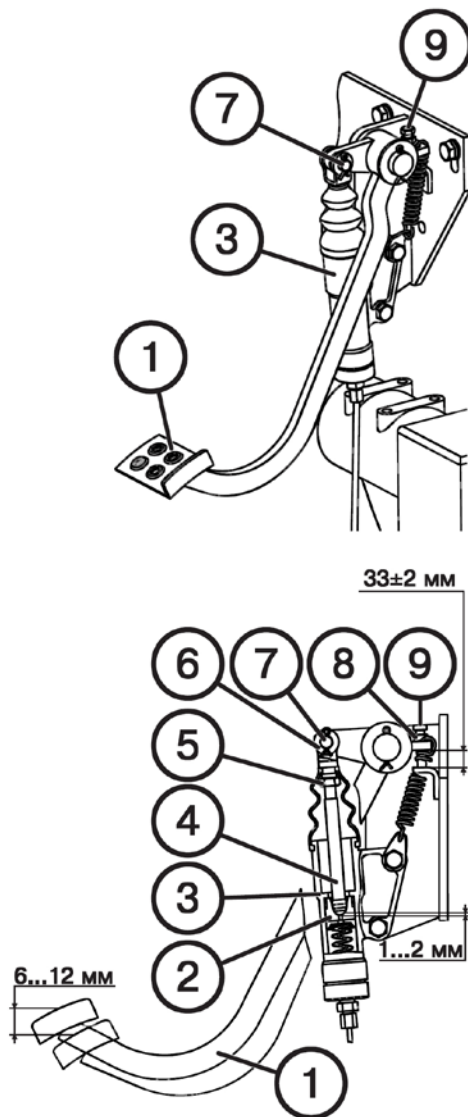

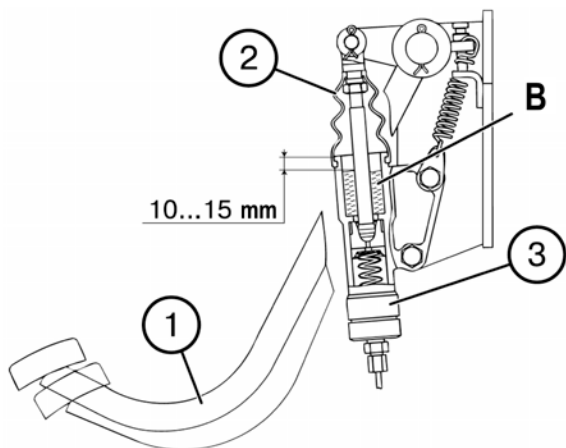

3.1. Remove the protective boot (2) and fill in the equalizing chamber "B" of the master brake cylinder with the "Neva" brake fluid to the level of 10...15 mm from the top edge of the chamber.

3. Set the hydraulic system with brake fluid and bleed air from their by performing the following operations:

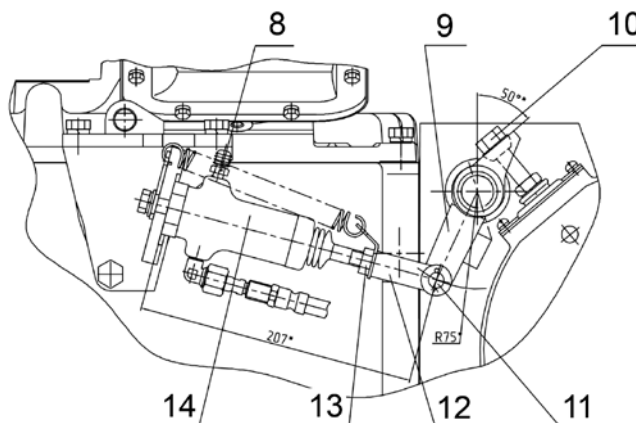
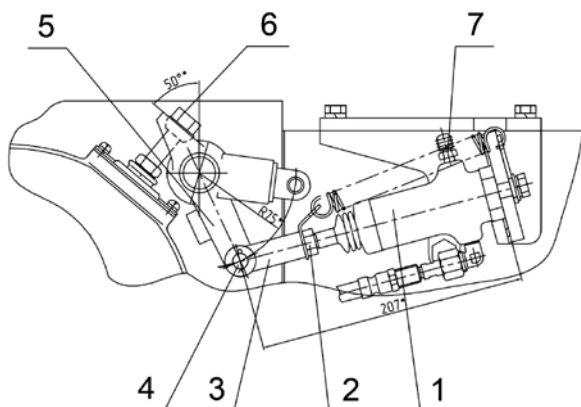

- Remove the caps from the bypass valves (7, 8), fit the tube to the head of the bypass valve of the left-hand working cylinder and put its free end into a transparent vessel with the capacity of at least 0.5 l filled with brake fluid to the half of the volume;
- Step on the reverse brake pedal (1) 4...5 times and, while holding it in the depressed position, turn the valve of the left-hand service cylinder by 1/2...3/4 revolutions after the full travel of the pedal and, when some quantity of the fluid will be removed from the system, turn the valve in and release

the pedal. **Step on the pedal quickly and release the same smoothly!** Repeat this operation several times until complete removal of air from the system. Remove the tube from the valve and refit the protective cap.

- Bleed air from the hydraulic actuator of the right-hand brake.

Fill the equalizing chamber "B" of the master brake cylinder of the reverse (3) with brake liquid to the specified level and fit the protective boot of the master cylinder.

PNEUMATIC ACTUATOR OF THE TRAILER BRAKES

The tractors can be equipped with two-line brake pneumatic actuator for the trailers equipped with pneumatic brake actuators.

The pneumatic drive is used also for inflating the tyres and for other purposes where the energy of compressed air is required.

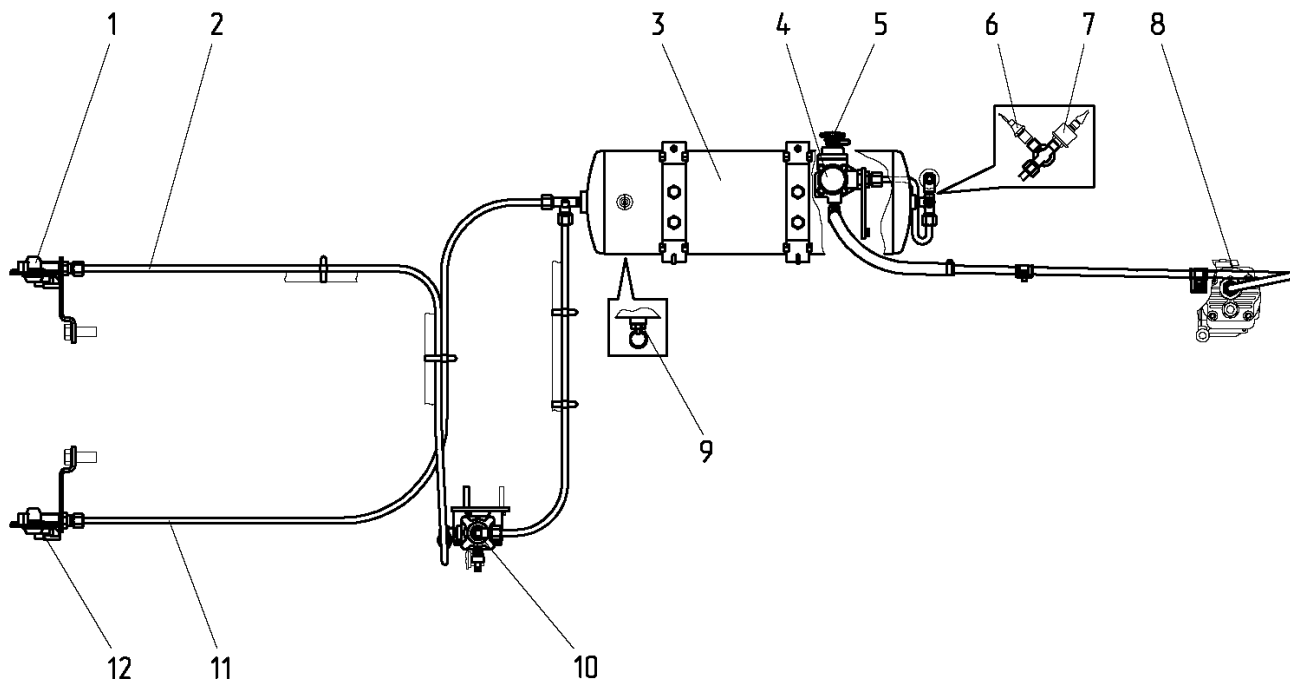

1, 12 – coupling heads; 2 – control manifold; 3 – bottle; 4 – pressure regulator; 5 – air intake valve; 6 – air emergency pressure sensor; 7 – air pressure sensor; 8 – compressor; 9 – condensate draining tap; 10 – brake valve (two-line); 11 – supply manifold.

Air is taken up into the pneumatic actuator from the engine inlet manifold. The compressor (8) compresses the air and feeds it to the air bottle (3) through the pressure regulator (4) maintaining the required pressure level in the air bottle. From the air bottle compressed air is fed to the brake valve (10) and further into the supply manifold (11) with the coupling head (12) (with a red cap), which is permanently under pressure. The brake valve (10) is connected with a coupling head (1) (with a yellow cap) by means of the control manifold (2). There is no pressure in this manifold.

The brakes of trailers and agricultural machines are controlled in two modes: direct and automatic one.

When using the trailer with a two-line pneumatic actuator, the coupling heads of the trailer are connected to the coupling heads (12) (with a red cap) and (1) (with a yellow cap), i.e. to the supply manifold (11) and to the control manifold (2). Here compressed air is fed permanently to the trailer through a supplying manifold (11). On stepping on the brake pedals or applying the parking brake, the compressed air is fed to the trailer through the brake valve (10) and control manifold (2). The trailer air distributor operates to feed the compressed air from the bottle into the brake chambers and the trailer gets braked.

The direct control of the brakes is achieved by raising pressure in the control manifold (2) up to 0.65...0.8 MPa when braking the tractor. As this takes place, the supply manifold (11) remains pressurized with the compressed air supply

into the pneumatic system of the trailer maintained.

The automatic control of the brakes (automatic braking) is achieved in case of breakage of the coupling and detachment of the pressure due to the pressure drop in the trailer supply manifold.

The pneumatic actuator is provided with the valve-type coupling heads (1, 12). The valves of the coupling heads keep the compressed air from leakage when using the pneumatic actuator without trailer (for example, when inflating the tyres) and in case of emergency detachment of the trailer. When the brake manifolds of the trailer are connected with the manifolds of the tractor, the coupling heads get open that allows the compressed air to pass from the pneumatic actuator of the tractor to the trailer. It is recommended to connect the pneumatic manifolds with no pressure in the air bottle (3) of the tractor.

The air pressure in the bottle (3) is monitored by the air pressure gauge and red warning lamp of emergency air pressure (installed in the dashboard), air pressure sensors (7) and emergency air pressure sensors (6).

The condensate draining tap (9) is provided for removing the condensate from the bottle (3). To drain the condensate, deflect the pusher aside and upwards by means of a ring.

The air is taken up from the pneumatic actuator (for inflating tyres, etc.) through the air intake valve (5) of the pressure regulator (4).

Checking and Adjusting the Brake Valve of the Pneumatic System and Its Actuator

The brake valve actuator shall be adjusted with the pedals of service brakes not stepped on and parking-and-reserve brake fully released which shall be preliminary adjusted.

1. Connect air pressure gauges with a scale of at least 1 MPa (10 kgf/cm²) to the coupling control head (with a yellow cap) of the pneumatic actuator of the tractor.

2. Turn the compressor ON and fill in the air bottle to the pressure of 0.77...0.8 MPa (7.7...8.0 kgf/cm²) as read on the pressure gauge located on the dashboard.

3. The air pressure as read on the pressure gauge connected to the coupling head (with a yellow cap) of the control manifold shall be equal to zero. Push the interlocked brake pedals all the way over their maximum stroke. The pressure shall increase to 0.65...0.8 MPa (6.5-8.0 kgf/cm²). Release the brake pedals. Apply the parking brake by pushing its handle as far as it will go. The pressure shall increase to 0.65...0.8 MPa (6.5...8,0 kgf/cm²). If the pressure reading of the pressure gauge connected to the head of the coupling manifold does not correspond to the above values, perform the following operations:

4. Check the length of the rod (1) assembled. Its length should ensure an easy (without excessive tension) coupling to the lever (6) by means of the pin (5). If necessary, adjust the same by rotating the end-piece (4).

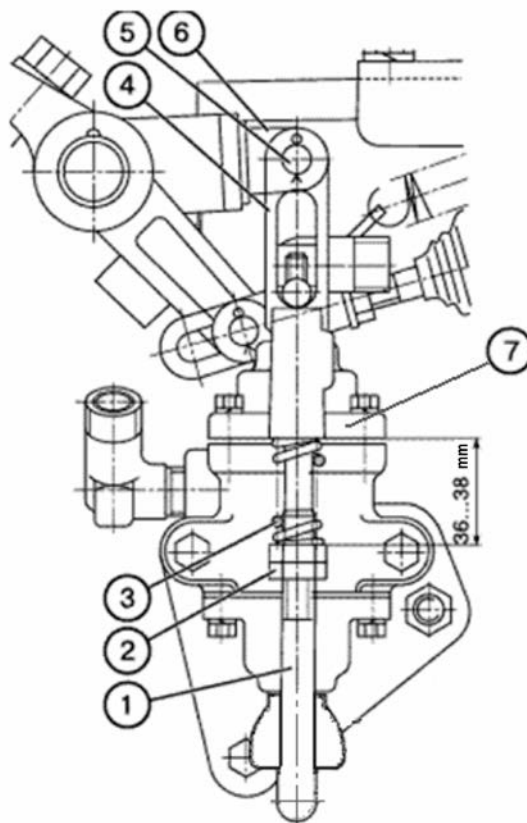

5. Check and, if required, adjust compression of the spring (3) to the dimension of 37 ± 1 mm by rotating the nuts (2) and lock them. Check the brake valve for proper operation in accordance with item 3

6. If the air pressure as read on the pressure gauge connected to the coupling head fails to reach the required valve, replace the brake valve (7).

IMPORTANT! If the brake valve and its actuator are adjusted correctly, the pressure as read on the pressure gauge connected to the coupling head (with a yellow cap) of the control manifold shall be equal to zero, when the pedals of service brakes are not stepped on and parking-and-reserve brake is fully released.

HYDROSTATIC POWER STEERING

Forward-Motion HPS

The HPS is intended for controlling the turning of the steerable wheels and reducing the force to be applied to the steering wheel for turning the tractor. The HPS consists of a metering pump (1), two differential hydraulic cylinders (3)

executing the turn, feeding pump (2) driven from the engine and hydraulic fittings.

The HPS oil tank is the right-hand section of the oil tank (4) with the 25-micron filter of the working fluid.

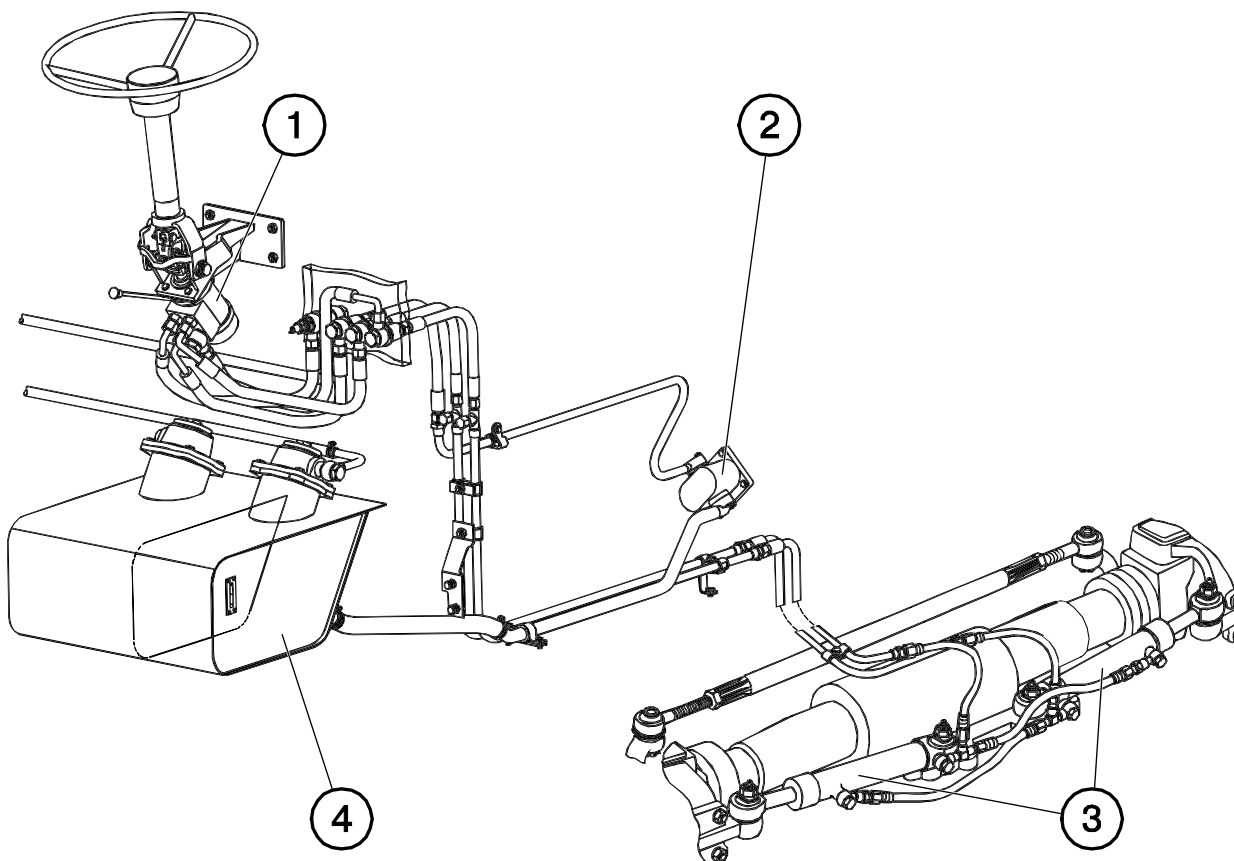

1 – metering pump; 2 – feeding pump; 3 – hydraulic cylinders; 4 – oil tank.

Construction and Operation of the HPS

The direct-acting metering pump (1) is installed on the bracket of the steering column; the turn hydraulic cylinder (3) – on the brackets attached to the FDA and the feed pump (2) – on the engine. The metering pump is connected to the chambers of the hydraulic cylinder of turning, feed pump and oil tank via pipelines.

When in a straight-ahead motion, the cylinder chambers are closed by the meter-

ing pump spool belts, and the oil fed from the feed pump and brought to the metering pump returns to the oil tank. When the steering wheel is turned, the metering spool-valve is displaced providing in such a way for oil supply to the chambers of the hydraulic cylinder of turning in the amount proportional to the angle of turn of the steering wheel.

Recommendations for Operation of the HPS

When assembling the HPS:

- Install properly the oil pipelines and hoses in accordance with the hydraulic diagram;
- Protect the connecting holes of the metering pumps, hydraulic cylinders, poi pipelines and high-pressure hoses against penetration of dirt;
- Prior to starting the engine, check the tightening of all the connections of the HPS hydraulic system;
- When tightening the fasteners, apply the required torque;
- Fill the oil tank to the upper limit as seen on the level indicator;

• Bleed air from the hydraulic system. To do this, proceed as follows:

1. Start the engine. Turn the steering wheel in both directions 3-4 times at the idling rotational speed of the engine without reaching the extreme positions of turning of the steerable wheels. Add oil to the tank to the required level.
 2. Turn the wheels from one stop to another 2-3 times. Hold the steering wheel at the extreme positions for 4...5 seconds.
 3. If necessary, eliminate the oil leaks and add oil to the top level of the tank.
- Drive the figure of eight to check the operation of the steering control.

Metering Pump

The metering pump consists of assembly I, distributor II, non-return valve (9), two

anti-hammer valves (7), relief valve (6) and two anti-vacuum valves (8).

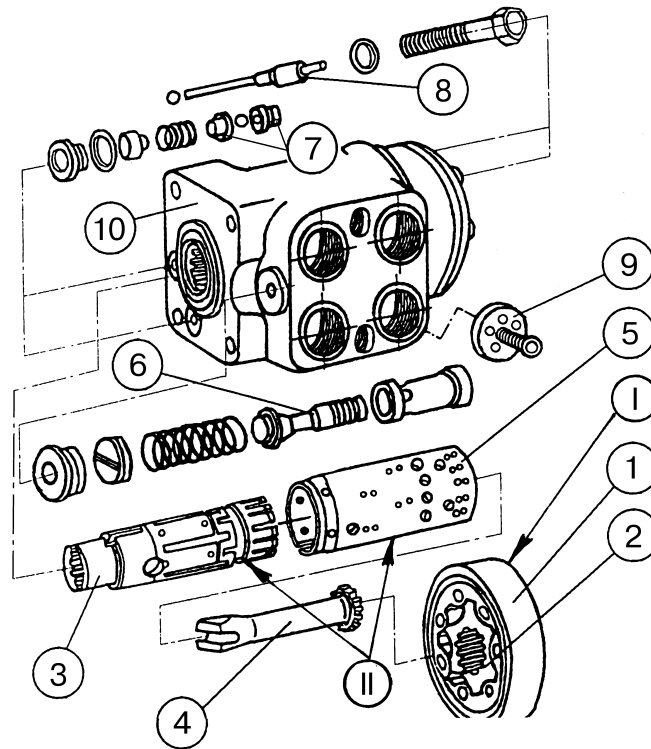

1 – stator; 2 – rotor; 3 – spool valve; 4 – power shaft; 5 – sleeve; 6 – relief valve; 7 – anti-hammer valves; 8 – anti-vacuum valves; 9 – non-return valve; 10 – body.

I – pumping assembly; II - distributor

The Gerotor pumping assembly I consists of the stator (1) fixed on the body and rotating rotor (2) connected to the spool valve (3) by the power shaft (4). The distributor II consists of the body (10), sleeve (5) and spool valve (3) splined onto the tail-end of the power shaft of the steering column:

The relief valve (6) limits the maximum pressure in the pressure mainline to within 17.5...18.0 MPa (175...180 kgf/cm²) in the HPS system with the double-rod hydraulic cylinder or to within

14.0...14.5 MPa (140...145 kgf/cm²) in the HPS system with two hydraulic cylinders of steering control.

The anti-hammer valves (7) limit pressure in the cylinder mainlines at impact loads. The pressure setting of the anti-hammer valves is within 22.5...24.5 MPa (225...245 kgf/cm²).

The anti-vacuum valves (8) make it possible to ensure the required supply of the working fluid into the hydraulic cylinder in the emergency mode and in case of operation of the anti-hammer valves.

Hydraulic Cylinder of Steering Control

The tractor is equipped with the FDA with two hydraulic cylinders (3) and transverse control arm (4) installed behind the FDA (see Figure below).

The rods of the hydraulic cylinders are connected with the pivot rods (2) of the planetary wheel FDA through the taper pins (1) and the bodies of the hydraulic

cylinders are connected with the lugs made of the central reduction gear casing. The spherical joints (5) requiring the periodical lubrication through the provided press lubricators (6) are installed in the ears of the casings of the wheel reduction gears and in the heads of the rods.

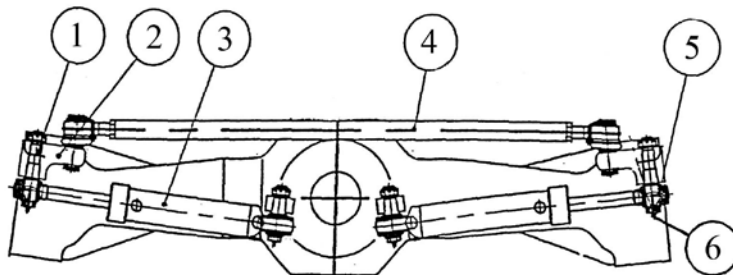

FDA with two hydraulic cylinders in the steering linkage and transverse control arm:

- 1 – taper pin; 2 – reduction gear lever; 3 – hydraulic cylinder; 4 – transverse control arm; 5 – spherical joint; 6 – press lubricator

The hydraulic cylinder of the steering wheel (see Figure below) consists of the body (3) rod (4), piston (1), cover (6) and sleeve nut (8). The piston is fastened to the rod by means of the nut (15) which is locked by punching of the shoulder into the slots of the rod (4). The spherical ball-and-socket bearings (7) having the channels on the internal raceway for lubricating the friction sur-

faces through a lubricator in the pin are installed in the lugs of the body and rod. The cup (9) (scraper), rod guides (13) excluding the friction of the rod and cover and rod seals (10) are mounted in the cover (6). The combined seal (14) is fitted on the piston to exclude the friction of the piston and sleeve of the body.

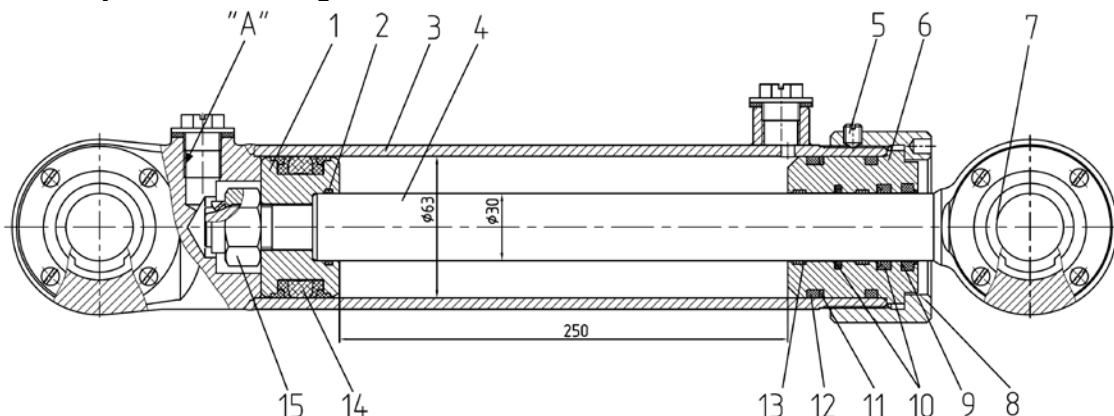

Hydraulic cylinder of the steering control

- 1 – piston; 2, 12 – sealing ring; 3 – body; 4 – rod; 5 – lock screw; 6 – front cover; 7 – spherical bearing; 8 – sleeve nut; 9 – rod cup; 10 – rod seals; 11 – protective ring, 13 – rod guide, 14 – piston seal; 15 – piston nut.

Oil Tank of the HPS

The oil tank is a welded structure with the capacity of 12 l combined with the HLL oil tank in a single housing. A draining filter (4) with a 25-micron replaceable filter element is mounted in the housing. The filter is filled with oil through the filter cap. The filler neck plug (3) contains a relief valve (2) which is screwed out together with the plug when filling the tank. The oil tank is equipped with a breather, oil gauge (1) as well as unions for oil intake and draining.

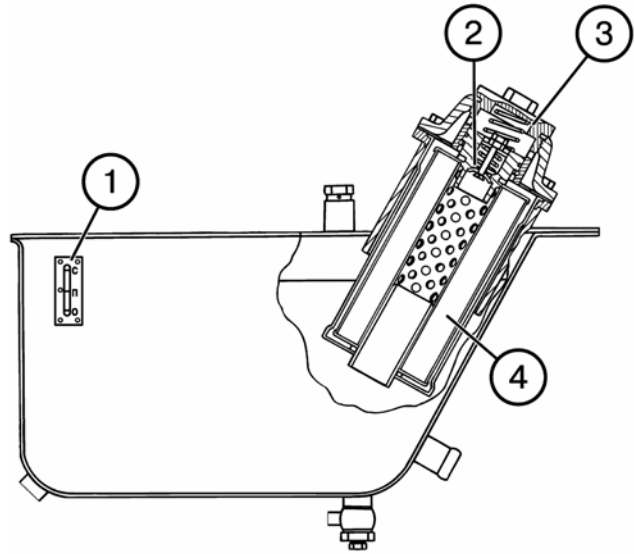

HPS of the Reversible BELARUS-1523B/1523B.3 Tractor

The HPS of the reversible tractor consists of two metering pumps (2 and 3), reverse tap (1), two differential hydraulic

cylinders (4) executing the turn, feeding pump (7) driven from the engine and hydraulic fittings.

Hydraulic Diagram of the HPS

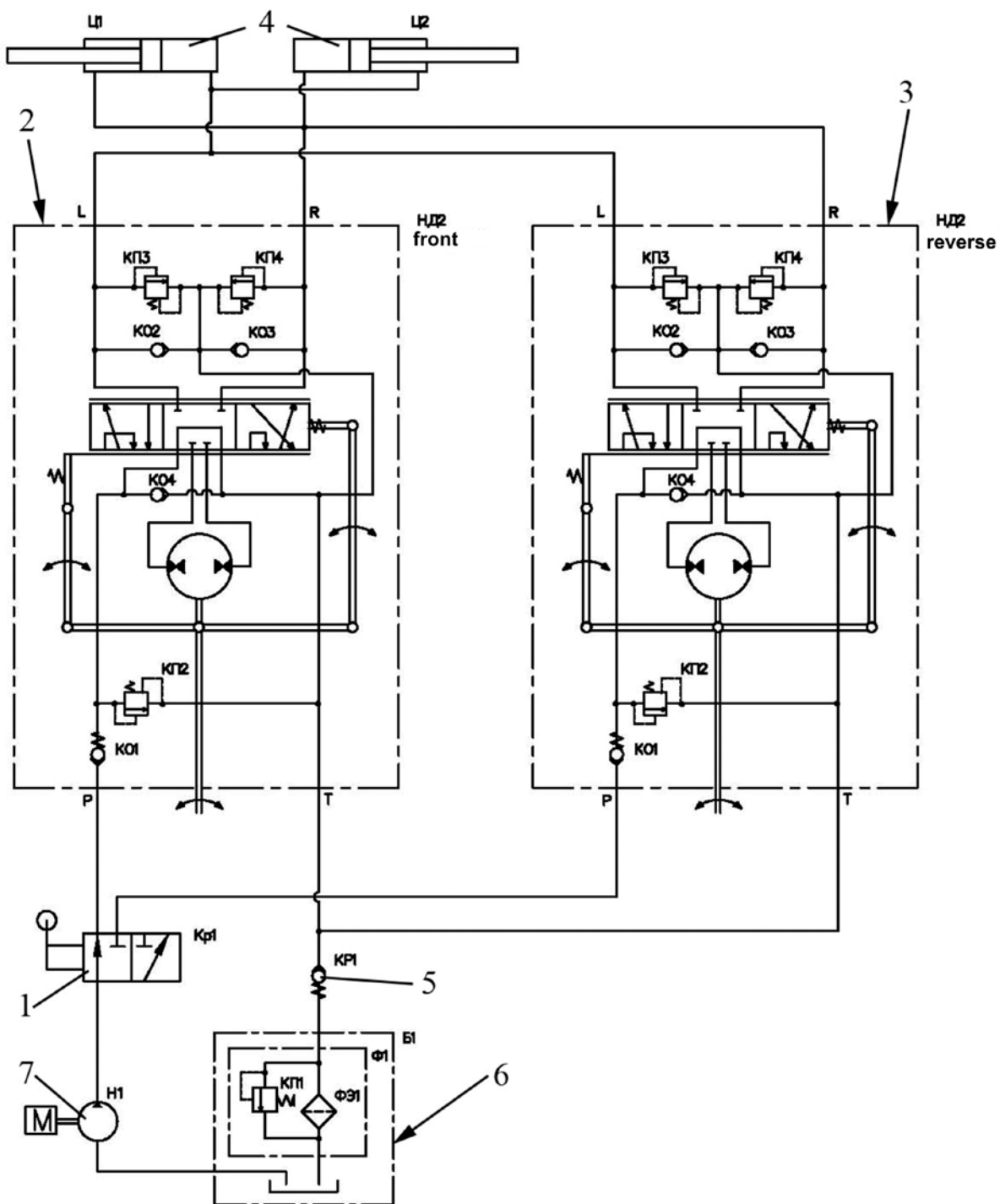

1 – reverse tap (Kp 1); 2 and 3– metering pump (HД2); 4 – hydraulic cylinders (Ц1 and Ц2); 5 – pressure reduction valve (KP1); 6 – oil tank (Б1); 7– feeding pump (H1); KO1 – hydraulic check valve; KO2, KO3 – anti-vacuum hydraulic valves; KO4 – hydraulic check valve; КП2 – hydraulic relief valve; КП3, КП4– anti-hammer hydraulic valves; Ф1 – draining filter; ФЭ1 – filter cartridge ЭФОМ 635-1-06; P – discharge; T – draining; L – left turn; R – right turn.

The metering pumps (2 and 3) are installed on the steering columns fastened on the front and rear walls of the cab, respectively; the hydraulic cylinders of turning (4) are installed on the front axle of the tractor, the feeding pump (7) is installed on the engine and the reverse tap – on the clutch housing. The metering pumps (2 and 3) are connected by means of the oil pipelines with the chambers of the hydraulic cylinders of turning, feeding pump and oil tank (6). The reverse tap sends the oil flow from the feeding pump to one of the metering pumps. During the straight-ahead motion, the chambers of the cylinder (4) are closed by the spool belts of the metering pump (2 or 3), and the oil fed from the feed pump (7) and brought to the metering pump (2 or 3) returns to the oil tank (6). When the steering wheel is turned, the spool valve of the metering pump (2 or 3) is displaced providing in such a way for oil supply to the chambers of the hydraulic cylinder of turning (4) in the amount proportional to the angle of turn of the steering wheel. From the other chamber of the hydraulic cylinder (4), oil returns into the oil tank through the metering tank (2) or (3).

ATTENTION!

The hydraulic system of steering control (HPS) of the BELARUS-1523B/1523B.3 tractors is provided with the reverse tap (1) for ensuring the tractor steerability when moving in both forward and reverse direction.

The reverse tap (1) is installed to the right on the clutch housing.

The reverse tap (1) is controlled by shifting the handle to one of two positions until it is fixed in each of them.

Recommendations for use

Prior to starting the engine, it is necessary to make sure that the control lever of the reverse tap (1) is set to the position corresponding to the selected direction of travel of the tractor.

Here:

- for driving the tractor during the forward-motion mode, the reverse tap handle (1) shall be lifted upwards until it is fixed;
- for driving the tractor during the reverse-motion mode, the reverse tap handle (1) shall be pushed downwards until it is fixed.

IMPORTANT!

To ensure the operation of the steering control in the necessary direction of motion of the tractor, the reverse tap (1) shall be only repositioned when the engine is not running to avoid the HPS feed pump breakage or rupture of the high-pressure feeding hoses and oil pipelines.

Reverse Tap

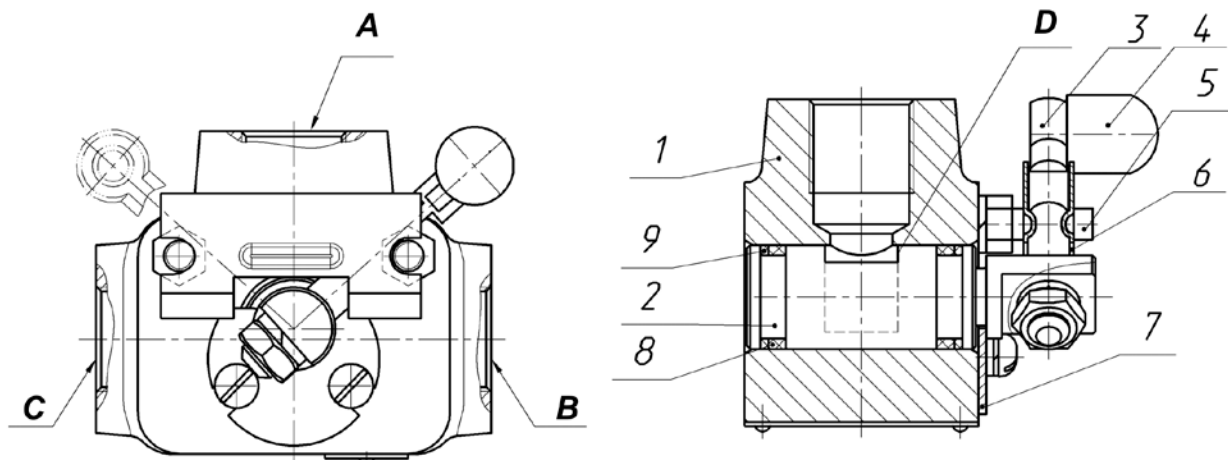

1 – casing, 2 – slide valve, 3 – lever, 4 – handle, 5 – stop, 6 – detent, 7 – slide valve detent, 8 – sealing ring, 9 – protective ring.

The reverse tap directs the working fluid flow from the feed pump connected with the chamber (A) to one of the metering pumps connected with the chambers (B) and (C), respectively.

The direction of the working fluid flow is changed by turning the tap lever

(3) to one or another side as far as it will go. Here the chamber (A) is connected with the chambers (B) or (C) by means of the slot (D) on the slide valve (2) and the operation of the front or rear metering pumps takes place.

RUNNING GEAR. TRACTOR WHEELS

The rear driving wheels of the tractor are installed on hubs which consist of split tapered inserts (3, 4) and hub body (2).

The inserts are closely drawn into the hub body by bolts (1).

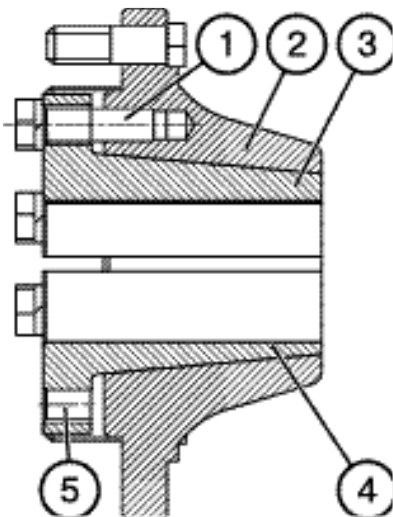

Hub:

1 – tie-bolts; 2 – hub body; 3 – upper insert; 4 – lower insert; 5 – threaded holes for dismantling

Changing the Tractor Wheel Track

The tractor wheel track can be changed within 1540...2090 mm over the front wheels and within 1600 to 2150 mm over the rear wheels.

The front wheel track is set depending on the relative positioning of the wheel disk with respect to the flange and the wheel rim with respect to the disk.

The fitting diagram and the wheel track dimension for tyres 420/70R24 are given below.

Fitting diagram and wheel track dimension for tyres 420/70R24

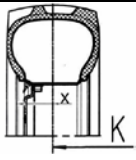
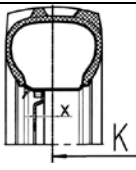
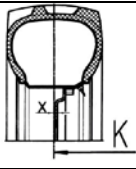
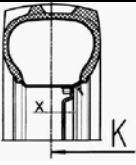
	Variants of disk-to-rim positioning	Disk offset X, mm	Tractor wheel track, mm (tyres 420/70R24)
Standard disk attachment with wheel rim re-positioning		+140	1540
		+90	1635
		-18	1850
		-68	1950

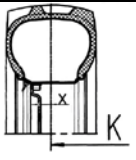
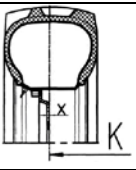
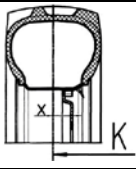
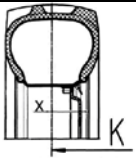
	Variants of disk-to-rim positioning	Disk offset X, mm	Tractor wheel track, mm (tyres 420/70R24)
Repositioning of disk and rim		+56	1700
		+6	1800
		-102	2020
		-152	2090

To change the rear wheel track, shift the hub together with the wheel over the axle-shaft and rearrange the wheels from one side to another.

To change the wheel track, proceed as follows:

1. Place the tractor on a flat, level ground.
2. Clean the axle-shafts from dirt.
3. Jack the respective axle-shaft housing.
4. Turn out tie-bolts (1) (see Figure "Hub") on each insert (3, 4), using four of them for pressing out the inserts by driving these bolts into the threaded holes for dismantling (5). Loosen the other two bolts by three complete turns each.

To dismantle the wheel, drive in the dismantling bolts uniformly, until the insert get pressed out*.

5. Move the hub to the required wheel track (see Table below for setting the wheel track be measuring the dimension K from the end of the half-axle to that of the insert).
6. Screw in the coupling bolt using them for tightening the inserts.
7. Tighten all the bolts with applying the torque of 350...450 N•m (35...45 kgf•m) in several steps before tightening them to the specified torque.

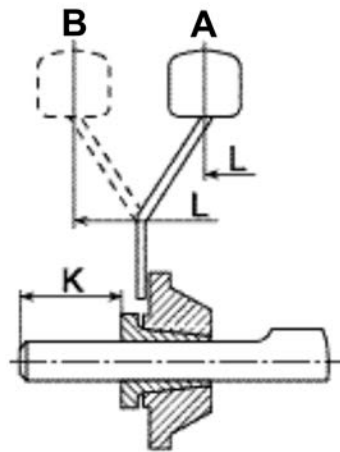

ATTENTION! Following tightening-up of bolts, check to see that the end-faces of the inserts are in the same plane to within 1...2 mm.

8. Adjust the wheel track on the other wheel.
9. Check and tighten the tie-bolts up after 3-10 hours of tractor operation.

If the wheel twinning is required, install the second wheels using the special spacer-ring pieces.

If the wheels have been removed when changing the rear wheel track, tighten the wheel nuts to 300...350 N•m (30...35 kgf•M).

Standard size of the tyres	Wheel position	Wheel track dimension "L", mm	Dimensional setting ** of the hub, K, to axle-shaft end-face, mm
520/70R38	A	1600...1900	155...5
	B	1950...2440	245...0
18,4R38	A	1480...1900	215...5
	B	1950...2440	245...0

* If it is impossible to pull the inserts out with the help of dismantling bolts, pour kerosene onto the insert parting joints; then, wait and screw the dismantling bolts into the threaded holes again rapping the hub body simultaneously until the inserts are fully out.

** Changing the wheel track by amount K corresponds to repositioning of the hub by K/2 on each side.

Twinning of the Rear Wheels

To improve the tractive and adhesive performance of the tractor when operating it with heavy agricultural machines on soils with low supporting capacity, additional rear wheels 18.4R38 can be installed through spacer-ring pieces.

To install the additional wheel, jack up the rear-end of the tractor having placed preliminarily chocks in front of and behind the front wheels; remove the main rear wheel, press the short bolts out of the hub (2) and install the elongated bolts (1) (complete with the spacer-ring piece). Put the main wheel onto the elongated bolts (1) and fasten it with

wheel nuts (3); then place the spacer-ring piece (4) onto the same bolts and fasten it with nuts (5). Then install the additional wheel onto the bolts (6) of the spacer-ring piece and fasten it with nuts (7).

Tighten the nuts (7) with applying the torque of 200...250 N•m (20...25 kgf•m).

When performing the lobs in the interrows with the width of 450 and 700 mm, it is recommended to install the twinned wheels 11,2R42 (see Section "Aggregation").

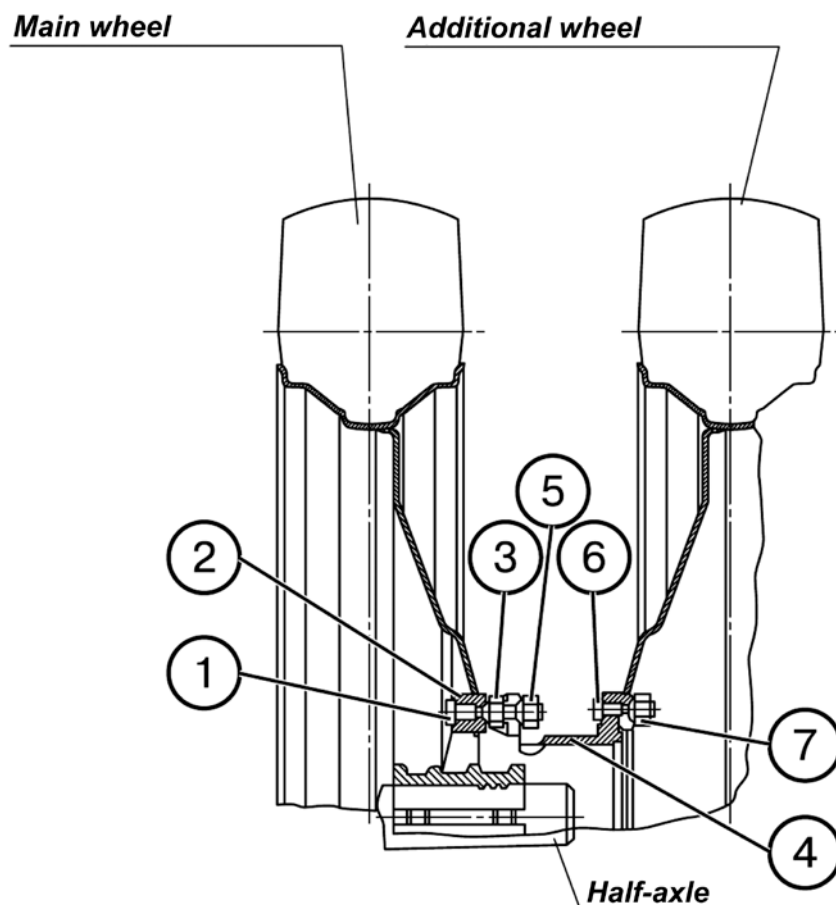

1 – elongated bolts; 2 – hub; 3 – nuts; 4 – spacer-ring piece; 5 – nut; 6 – bolts on the spacer-ring piece; 7 – spacer-ring piece nuts.

HYDRAULIC LIFT LINKAGE (HLL)

The system is designated for attaching the mounted and semi-mounted agricultural machines to the tractor, controlling their operation as well as ensuring the performance of the hydraulically-driven tools of the machines to be aggregated with the tractor.

Hydraulic System

The hydraulic system serves for operating the lift linkage and hydraulically driven tools of the agricultural machines aggregated with the tractor. It provides the means of employment of height, draft, position or combined control modes for adjusting agricultural machine/implement operating depth.

The lift linkage is controlled by an electromagnet controller which allows for

employment of the draft, position and combined controls of tools when operating the mounted and semi-mounted agricultural machines and implements.

The hydraulic system (see below) involves an oil tank (1) with a 25-micron discharge filter (2), gear pump (4) with its drive (3) mounted on the left-hand side of the clutch housing, and an integrated block BOSCH (5)* consisting of a spool valve-type distributor for controlling the external hydraulic cylinders and a controller for electromagnetic control of the mounted implement (MI). The hydraulic units are coupled through a low-pressure mainlines (7, 8) and the pumping under pressure is performed through the high-pressure hose (6) and pipeline (9).

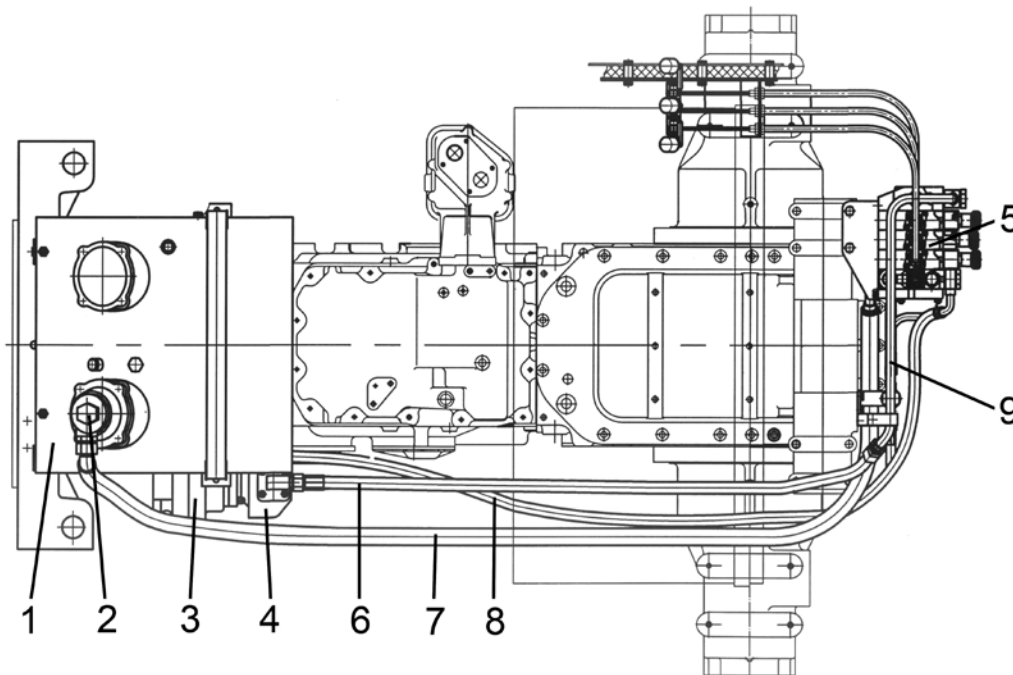

1 – HLL oil tank; 2 – discharge filter; 3 – oil pump drive; 4 – oil pump; 5 – integrated block* (hydraulic distributor + controller with electromagnetic control); 6, 9 – pressure oil pipeline; 7, 8 – drain oil pipeline.

* Prior to installation of the integrated block, an independent distributor and controller BOSCH assembly may be employed.

HLL Oil Tank

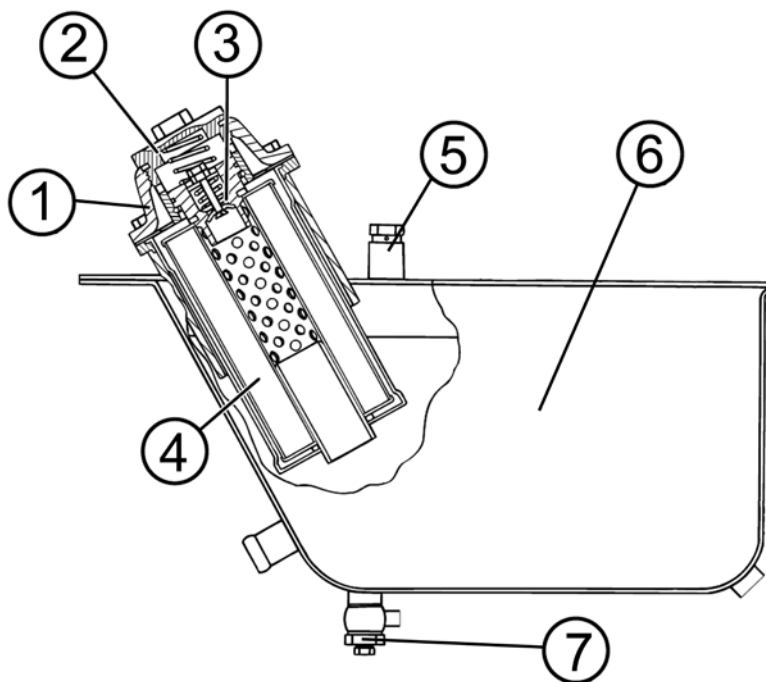

1 – cap; 2 – filler neck plug; 3 – relief valve; 4 – paper filter element; 5 - breather; 6 – tank casing; 7 – drainage plug.

The oil tank (6) consists of two sections (HLL and HPS). The left-hand section of the HLL and HPS shared tank is a welded structure with the capacity of 35 l. It houses a discharge filter with a replaceable paper filter element (4) (Type Regotmas 635-1) which filters the particles down to a 25-micron size. The tank

is filled with oil through the filter cap (1). The filter relief valve (3) is built into the plug (2); it is screwed out together with the plug (2) when filling the tank with oil. The oil tank is equipped with a breather (5), oil gauge as well as with plug (7) for draining oil from the hydraulic system.

The oil pump of the hydraulic system is of gear type with clockwise rotation. The pump drive can be disengaged. It is independent on the clutch and installed on the left-hand side of the clutch housing.

The drive consists of housing (1), gear (2) splined onto the shaft (3); the latter is

supported in two ball bearings. The balls (4) placed into holes in the shaft (3) lock or unlock the shaft with splined bushings (5, 7) by means of the race (6). The race is controlled by a fork through the tetrahedron of the shifter axle (7).

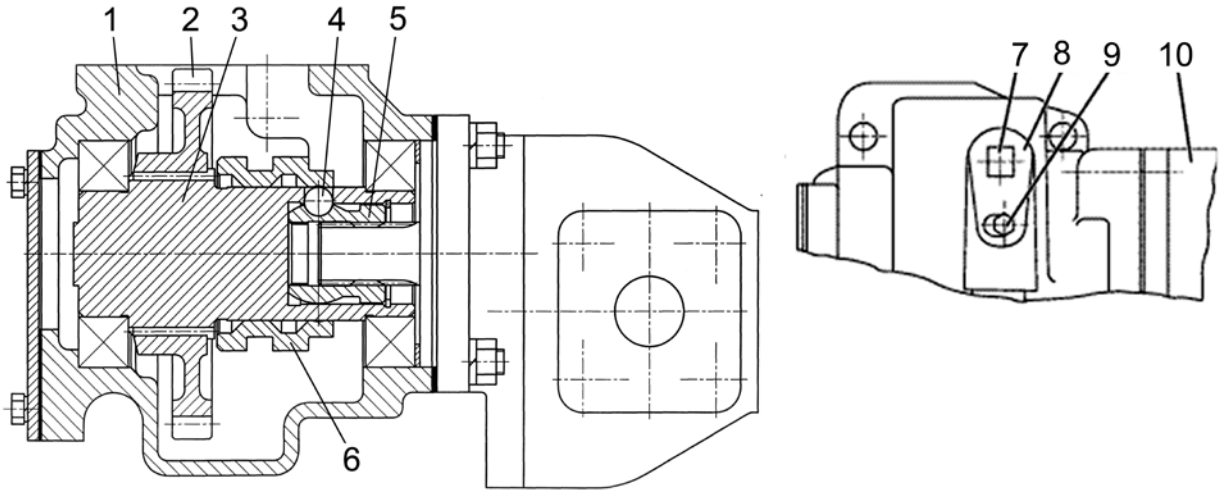

1 – drive housing; 2 – drive gear; 3 – shaft; 4 – balls; 5 – pump shaft bushing; 6 – race; 7 – shifter axle; 8 – lock plate; 9 – bolt; 10 – pump.

The gear (2) is in constant mesh with the PTO drive gear. When in the disengaged position (refer to the engagement diagram), the race (6) is displaced to its rightmost position. Under the centrifugal force, the balls (4) come out of engagement with the bushing (5), and the shaft (3) together with the gear (2) are freely riding in the bearings. When engaged (the race is shifted to its leftmost position), the balls (4) enter the indentations of the bushing (5) forced by the tapered edge of the race (6) and the rotation of gear (2) is transmitted to the pump shaft through the shaft (3) and splined bushing (5). The drive maintains the rotational

speed of the shaft of the pump (11) of 1980 rpm at the engine rated speed, and the ball coupling (3, 4, 5, 6) makes it possible to engage and disengage the pump with the engine running at the minimum idling speed.

To engage/disengage the pump:

- a) loosen the bolt (9) by 1.5...2.0 revolutions;
- b) turn the tetrahedron of the shifter axle (7) clockwise/counter-clockwise, respectively, up to a stop;
- c) tighten up the bolt (9).

The “BOSCH” Integrated Block is composed of a spool valve-type hydraulic distributor (3) for controlling the external hydraulic cylinder and regulator (2) for electromagnetic control of the HLL.

The Hydraulic Distributor (3) is of three-section, four-position through-type and manufactured by the BOSCH Com-

pany. The spool valves of the 2nd and 3rd sections can be fixed in the “Neutral” and “Floating” positions. The spool valve of the 1st section is fixed in the “Lift” position. It is provided with an automatic return mechanism from the “Lift” position to its “Neutral” position on reaching the pre-set pressure.

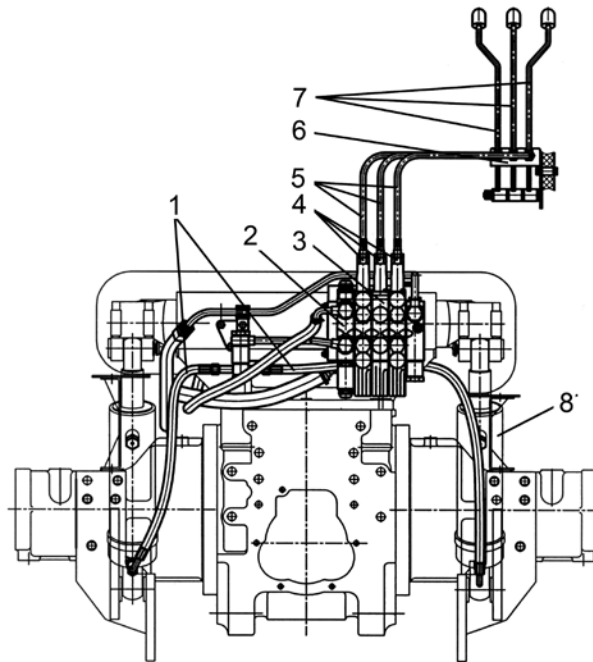

1 – high-pressure pipeline; 2 – controller EHR-23 LS *; 3 – hydraulic distributor; 4 – spool valves (adapters); 5 – control cables; 6 – bracket; 7 – control levers; 8 – hydraulic cylinder Ц90x250 (2 off); “I” – 3rd spool valve lever; “II” – 2nd spool valve lever; “III” – 1st spool valve lever.

The outlet holes of distributor sections are used for connecting the rear leads of the hydraulic system; when a front hitch linkage is installed, the hydraulic cylinders are fed from the middle section of the distributor using high-pressure hoses (HPH).

The control of the distributor spool valves is exercised by means of double-acting cables (5) ensuring the control of the spool valves of the distributor (4)

Electrohydraulic Unit (РП70 + ЕНРНС1-ОС)

through the control levers (7) located in the panel to the right of the operator’s seat. Cable braiding is secured with nuts on the bracket (6) on the one side and in the distributor (4) adapters on the other side.

Shifting the lever from its “neutral” (H) position forward in the direction of the tractor travel sets the spool valves to the “drop” and “float” positions while pulling the same rearward – to the “lift” position.

* Or independent controller EHR4.

The electrohydraulic unit (PΠ70 + EHPHC1-OC) consists of the electrohydraulic regulator manufactured by the Argo-Hytos company (Czechia) complete

with the distribution sections of the PΠ70 distributor manufactured by the Hydroprivod Plant (Republic of Belarus).

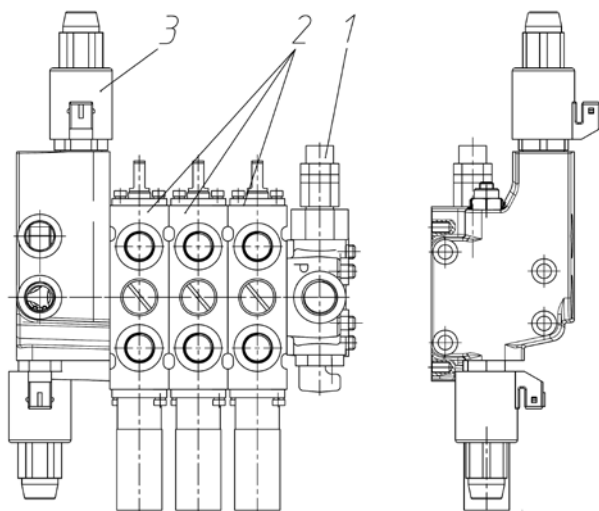

1 – PΠ70-20 cover; 2 – PΠ70-8-0-M distributor section; 3 – EHPHC1-OC regulator.

HLL Hydraulic Diagram with the Electrohydraulic Unit (PΠ70 + EHPHC1-OC)

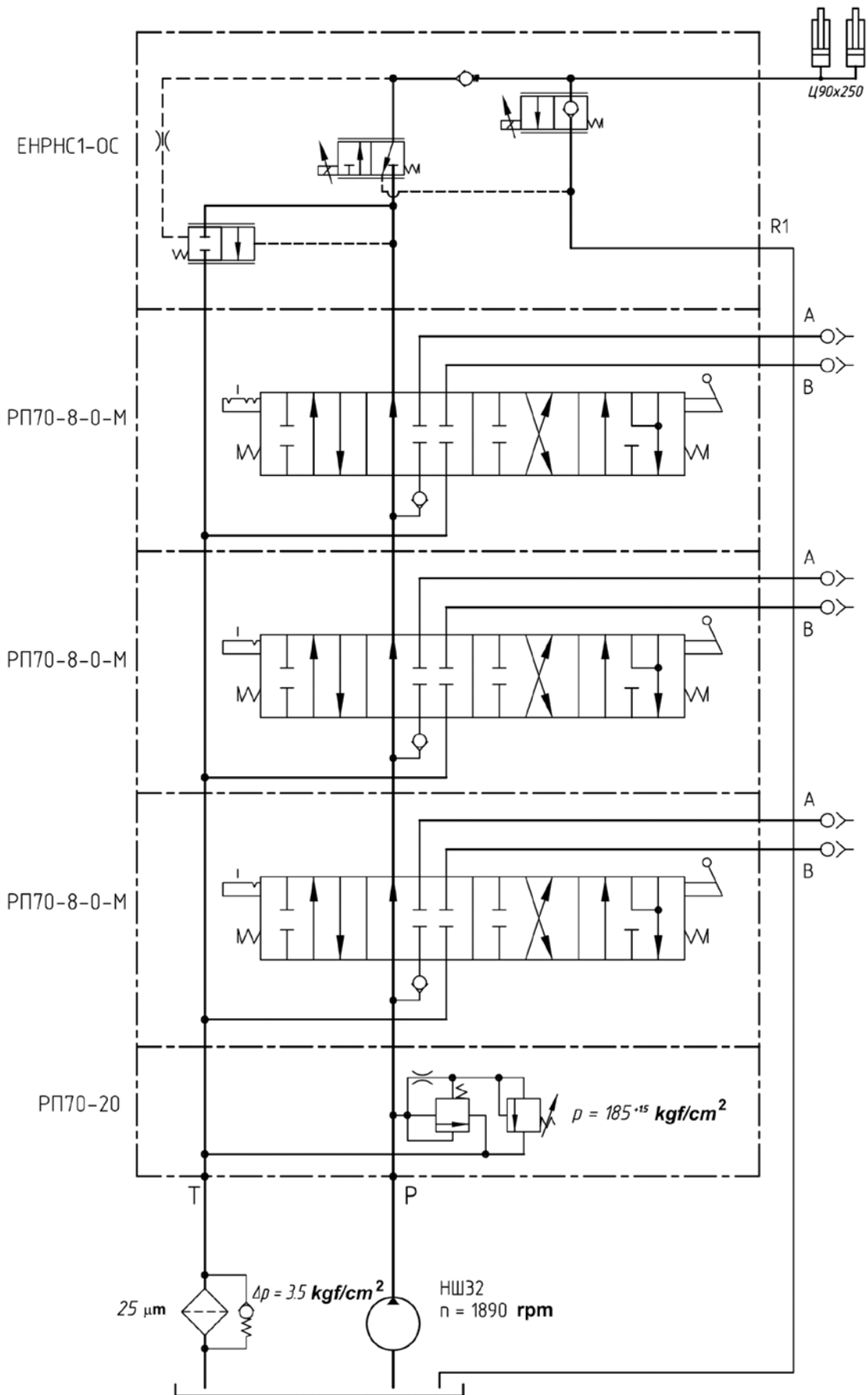

The HLL control and adjustment system includes an electromagnetically-controlled regulator, position transducer (an induction displacement transducer), draft transducer (two draft-measuring transducer fingers), control panel, electronic unit and cables assemblies.

The position transducer (6) is screwed into the socket in the rear axle cover (4) and by the eccentric (3) secured to the turn shaft (2). **To install the BOSCH transducer, proceed as follows:**

- Raise the RHL to its top position; in so doing, the transducer ball-point should be opposite to the mark "A", or slightly displaced towards mark "B";
- If it is not the case, loosen the screw (1) and turn the eccentric (3) through a required angle; then tighten the screw (1);
- Screw in transducer (6) by hand until it stops, then turn it off by 0.5...1.0 revolutions and lock it with the lock-nut (5). If the transducer is installed correctly, the warning light indicating the RHL lifting should go out when the mechanism is in its top position.

IMPORTANT! DO NOT overtighten the nut (5) to avoid damage of the sensor (6) made of aluminium alloy.

To install the ДП-01 transducer manufactured by the Izmeritel Plant, proceed as follows:

- Raise the RHL to its top position;
- Turn the setting screw (7) into the rear axle cover (4) up to the stop while directing it into the hole in the working surface of the eccentric (3);
- Tighten the bolt (1); turn out the setting screw (7) from the rear axle cover;
- Screw the transducer (6) until it rests against the eccentric and then turn it out by one revolution and lock it by means of the locknut (5). If the transducer is installed correctly, the warning light indicating the RHL lifting should go out when the mechanism is in its top position.

Variant of installation of the BOSCH position transducer

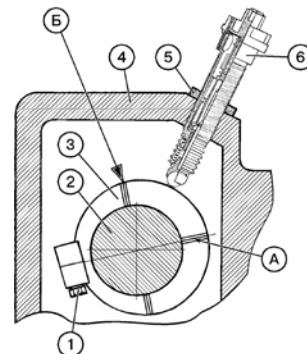

Variant of installation of the ДП-01 position transducer of the Izmeritel Plant

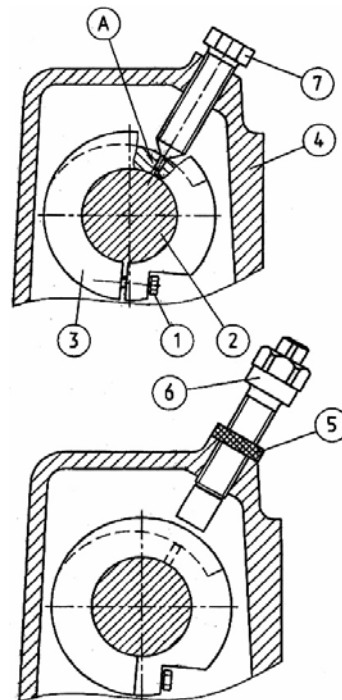

1 – screw; 2 – turn shaft; 3 – eccentric; 4 – cover; 5 – locknut; 6 – position sensor.

"A" is a mark on the ascending path of the eccentric;

"B" is a mark on the descending path of the eccentric.

The draft control transducer is made in the form of two draft-measuring fingers (5) inserted into the bracket (3); they serve as the axle for attaching the lower links (4).

The angular position of the finger in the bracket is determined by the clamp (1) which enters the slot of the draft-measuring finger and fastened to the bracket (3) by screws (2).

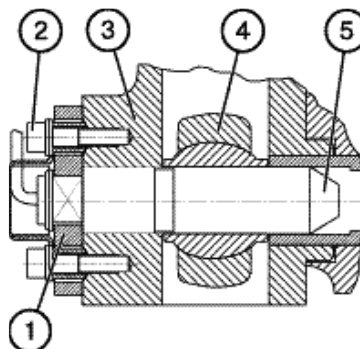

1 – clamp; 2 – clamp fastening bolt (2 pieces); 3 – bracket; 4 – lower link; 5 – draft-measuring finger (draft control transducer).

The control of the rear hitch linkage by means of the BOSCH controller is exercised from the main control panel RHL (see paragraph “RHL Control Panel”) located on the right-hand side of the operator’s seat as well as by means of two external control panels (1) located on the side surfaces of the rear wheel fenders.

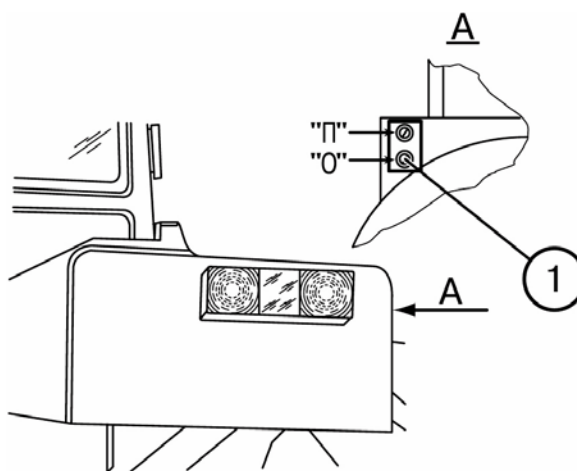

1 – external control panel; “П” – RHL lift pushbutton (“L”); “O” – RHL drop pushbutton (“D”).

RHL Electronic Control System

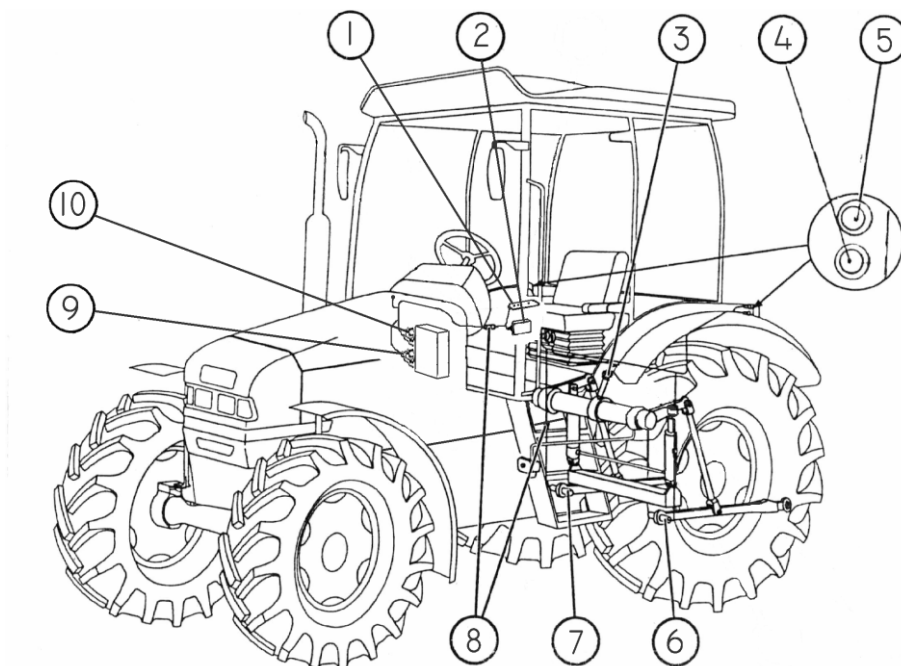

1 – RHL Control Panel; 2 – electronic unit; 3 – RHL position control transducer; 4 – external pushbutton for the RHL drop control; 5 – external pushbutton for the RHL lifting control; 6 – left-hand draft transducer; 7 – right-hand draft transducer; 8 – connecting bundles for controlling the electromagnet; 9 – electric valve for drop; 10 – electric valve for lifting.

The electronic part of the system works as follows. After starting the engine, the supply voltage is applied to the electronic unit (2) of the system. The electronic unit scans the transducers and system control elements and, after analysis, is-

sues the necessary commands to the controller electromagnets. The system is controlled from either control panel (1), located in the tractor cab or by means of the external control pushbuttons (4, 5) located on the rear wheel fenders.

RHL Control Panel Manufactured by the BOSCH Company

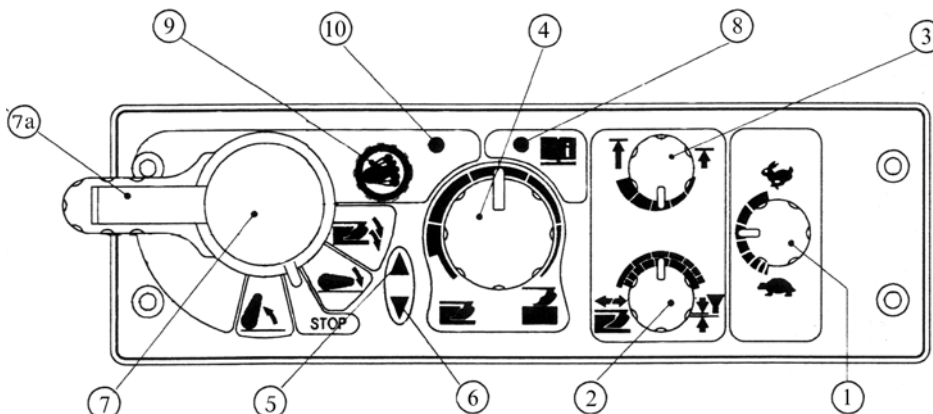

ПУ-03 RHL Control Panel Manufactured by the Izmeritel Plant

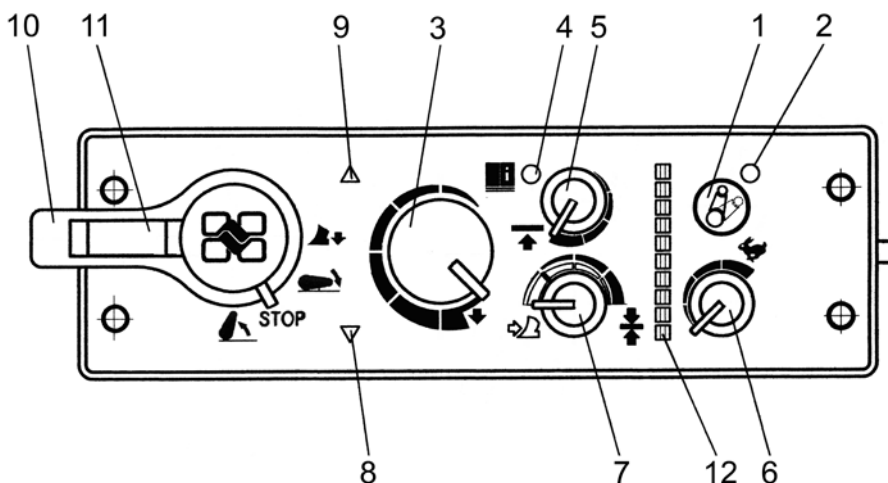

1 – damping knob; 2 – damping warning lamp; 3 – handle for adjusting the tillage depth (clockwise – shallower, counter-clockwise – deeper); 4 – red diagnostic alarm; 5 – handle for adjusting the limitation of lifting the hitch linkage (clockwise – maximum lifting, counter-clockwise – minimum lifting); 6 – handle for adjusting the drop rate (clockwise – quicker, counter-clockwise – slower); 7 – handle for selecting the adjustment method (clockwise – position one, counter-clockwise – draft one, in-between them – combined method); 8 – hitch linkage drop warning lamp (green); 9 – hitch linkage drop lifting lamp (red); 10 – hitch linkage control handle (upwards – lifting, downwards – drop, extra pressing down the handle in its bottom position – plough entry for ploughing, middle position – disengaged); 11 – interlocking switch (transportation) – locks mechanically the handle (10) in the top position by shifting the switch to the right; 12 – RHL position indicator (green, top mark of the scale: the RHL is in the top position, bottom mark of the scale: the RHL in the in the bottom position).

The sequence of operations of controlling the rear hitch linkage is as follows:

- Set the adjustment method by means of the handle (7) depending on the nature of job;

- set the working depth and height of the implement lifting in the transport position by means of the handles (3) and (5), respectively;
- the hitch linkage is dropped by shifting the handle (10) to the bottom fixed position. In this case, the lamp (8) lights up;

In the process of work, it is necessary to adjust the optimum conditions of operation of the trailed equipment:

- by means of the handle (7), set the combination of the adjustment methods;
- by means of the handle (6), set the correction rate;
- by means of the handle (3), set the tillage depth.

The sensitivity of the adjustments is assured by an automatic adaptive system which suppresses the excessively high adjustment rate in case of draft control. In this case, the average adjustment occurrence (frequency) is approximately equal to 2 Hz.

In case of intensive heating of the system, it is good practice to reduce the frequency of adjustment by shifting the handle (7) towards the position control mode and the handle (6) in the direction of the "turtle" symbol.

In case of swallowing-up (spring-out) of the plough when coming across patches of consolidated soils or hollows, force the plough deeper into soil by pressing the handle (10) to the bottom position. When released, the handle (10) will return to its fixed position "drop" to the depth set by means of the handle (3).

Raising of the tillage implement is achieved by shifting the handle (10) to its upper position. The lamp (9) lights up at the time of lifting.

ATTENTION! To avoid failure of the HLL pump, NEVER operate the tractor unless the lamp (9) would go out after the implement is out of soil.

It is important to get familiar with the following features of starting up the system for control of the rear hitch linkage:

1. After starting the engine, the diagnostics lamp (4) lights up to indicate that the control system is serviceable and locked;
2. To unlock the system, it is necessary to set the lift/drop handle (10) to the working position several times. When it will be done, the diagnostics lamp (4) goes out.
3. With the system is unlocked, the first engagement is performed at automatically limited rate of lifting of the rear hitch linkage from safety considerations. Next setting of the handle (10) to the working position removes the restriction on the lift rate.
4. The rear hitch linkage can be lifted and dropped from the external posts located on the rear wheel fenders in any control modes (the handles can be set arbitrarily). In this case, the control system operated from the cab is blocked.

WARNING. When using the external control posts, NEVER stand between the tractor and the machine to be attached. To avoid accidents, it is strictly prohibited to use the buttons for mechanical displacement of the electric valves of lifting and dropping the hitch linkage which are intended for adjusting the control system by qualified experts.

ATTENTION To prevent further penetration of tools (plough and the like) in case of tractor emergency stop, put the handle (10) to its "neutral" position. When already on move, shift the handle to the "drop" position (the plough will enter the soil to the prescribed operating depth).

Aside from the above-described functions, the electronic control system of the rear hitch linkage has a “damping” function (quenching of oscillations of the mounted implement when in transport).

To switch on the damping mode, proceed as follows:

- set the handle (10) to the “Lift” position (on doing this, the RHL is raised to its top position and automatically disengaged);
- press the “damping” button (1) (when it will be done, the RHL will move downwards by 3% of the full RHL travel) and the “damping” lamp (2) will go out.

The “damping” button is located on the RHL control panel (the pushbutton with the icon )

ATTENTION!

1. The “Damping” function is only operative when the handle (10) is set to the “Lift” position.
2. When on field jobs (ploughing, cultivation, and the like), the “Damping” function switch shall be in its “OFF” position.

Diagnosics of Faults

The BOSCH electrohydraulic control system has the self-diagnostics feature and, in case of detection of a fault, it generates coded data for the operator by means of a diagnostics warning lamp on the control panel. When no faults are detected in the system after starting the engine, the warning lamp is in constant glow. After manipulations of the RHL control handle upwards or downwards, the warning lamp goes out. When the control handle is set downwards, a green warning lamp lights up to indicate the drop of the RHL; when the handle is set upwards, a red warning lamp to indicate the lifting of the RHL.

If any faults are detected in the system (after starting the engine), the diagnostics warning lamp begins to give the coded information on the fault and, if required, cause the system to block.

The fault code is generated in the form of a two-digit number, the first digit of which is equal to the number of flashes of the warning lamp after a long pause. The second digit is the number of flashes after a short pause. For example, a long pause – lamp flashes three times, a short pause – the lamp flashes six times. This means that the system has a fault with a “36” code. Should several faults be detected, the system indicates one fault code after another, one by one, separated with a prolonged pause.

The system subdivides all the faults into three groups: major, average, and minor faults.

If **major** faults are detected, the adjustment operations are stopped and the system is disabled. It can be controlled neither from the main control panel nor from the external button posts. The diagnostics warning lamp indicates the fault code. The operation of the system is only

resumed when the fault is eliminated and the engine is restarted.

In case of **average** faults, the adjustment procedure is stopped and the system is blocked. It cannot be controlled from the main control panel, but can be controlled from the external button posts. The diagnostics warning lamp indicates the fault code. The operation of the system is only resumed when the fault is eliminated and the engine is restarted.

In case of **minor** faults, the diagnostics warning lamp shows its code. The system is still can controlled without blocking. When the fault is eliminated, the diagnostics warning lamp goes out.

If any fault is detected by the system, proceed as follows:

1. Stop the engine.
2. Set the controls on the main control panel of the RHL as follows:
 - The hitch linkage control handle – to the OFF position;
 - The lift limit adjusting handle – to the “0” position;
 - The soil working depth adjustment handle – to the “0” position;
 - The drop rate adjustment handle – to the middle position;
 - The “draft-position” mode adjustment handle – to the middle position.
3. Start up the engine and, if no faults are detected, proceed with field jobs. If the defects have not been eliminated in such a way, carry out malfunction diagnosis of the system and eliminate the troubles.

For a list of possible troubles, their diagnostics methods and remedies, see the section “Troubleshooting”.

ATTENTION!

1. The electrical connectors of the hitch linkage control system shall be only disconnected with the engine stopped.
2. The specified voltage values shall be only measured on a running engine in compliance with safety regulations for handling the live electrical products.
3. The pin numbering in the bundle connectors is indicated on the base elements of the connectors.

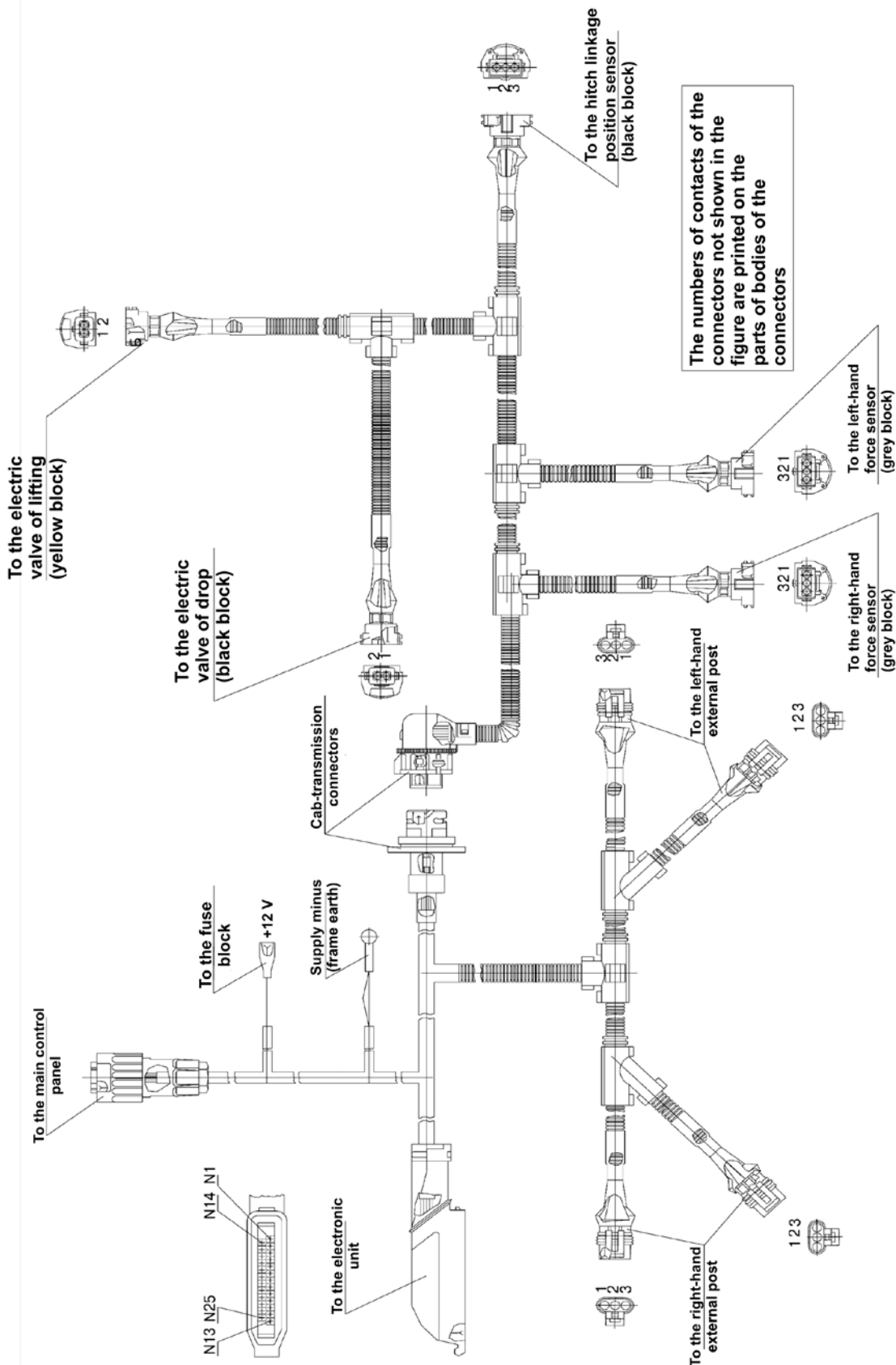

Connecting bundles of the RHL control system.

REAR HITCH LINKAGE (RHL)

The rear hitch linkage serves for attaching mounted and semi-mounted agricultural machines to the tractor. The mounted agricultural machines shall be attached to the tractor at three points: to the joint of the lower links and that of the top link, or by means of a pickup quick hitch mechanism.

The rear axle housings carry brackets (11), with two cylinders (4) mounted

thereon through pins (10). The cylinder rods are connected to the external levers (3) by means of pins (3a) (left- and right-hand). The external levers sit with their splined holes on the shaft (2); the latter is installed in the rear axle cover (1). The levers (3) are coupled to the lower links with lower rods (7) by means of the drop links (5).

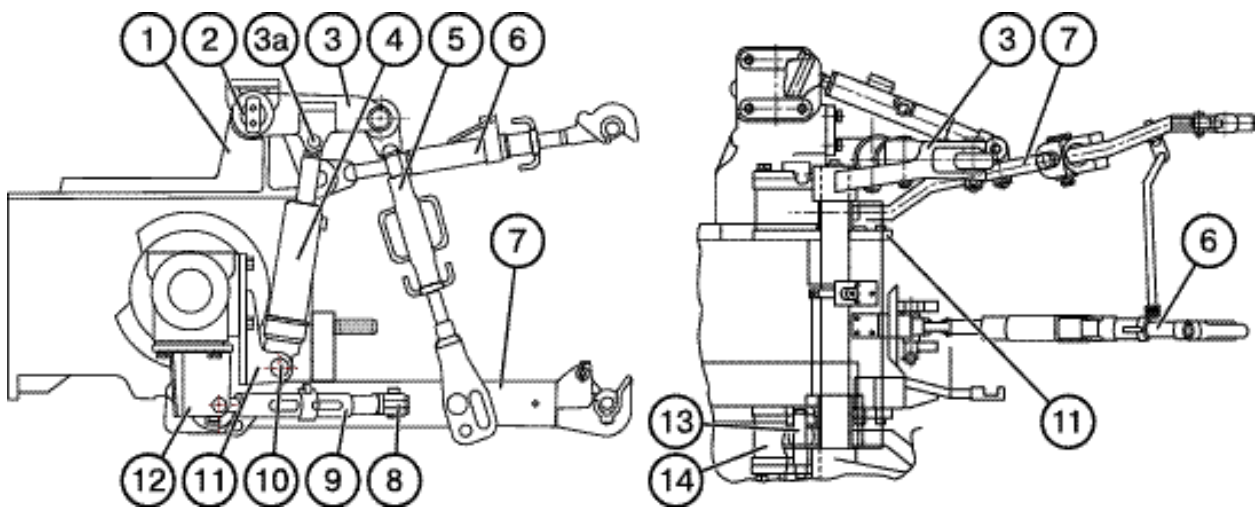

1 – rear axle cover; 2 – turn shaft; 3 – external levers (left-hand and right-hand); 3a – hydraulic cylinder rod pins; 4 – hydraulic cylinders; 5 – drop links; 6 – top link; 7 – lower links; 8 – lugs; 9 – turn-buckle braces; 10 – pins; 11 – brackets; 12 – turn-buckle brackets; 13 – fingers (draft control transducers); 14 – brackets.

The Lower Links are fitted in brackets (14) (right- and left hand ones) with their front joints through special pins (13) which are draft control transducers. The brackets are fastened to the side surfaces of the rear axle, under the housing flanges. The lower links have lugs (8), to which turn-buckle braces (9) are attached with their forks. The braces provide for adjustment of the agricultural machine cross-displacement in the working and transportation position.

The Top (Centre) Link (6) is fastened to the haul-and-draw coupler.

Turn-Buckle Brace

The brace consists of a screw (1), guide member (2), slide block (3) and gib-and-cotter (4).

The front end of the brace fitted with a spherical joint is connected to the brace bracket (12) through a pin, see page 158, while the rear end – to the lug (8) of the lower link (7).

There is a through-slot on the side surface of the guide member (2) and a through hole in the plane normal thereto.

The slide block is made with two through-holes in one and the same plane.

One of the two holes of the slide block is used to rigidly connect it with the guiding gib-and-cotter (4) when the tractor is used in a transport mission, cultivation and the like. The other hole serves to connect the sliding block with the guiding member when the gib-and-cotter is installed in the through slot when the tractor is running with a plough.

If necessary, slightly readjust of the turn-buckle brace length to install the gib-and-cotter into the guiding member slot and the sliding block hole by rotating the sliding block in one or other direction, with the sliding block preliminary disconnected from the lower link.

In case of tractor operation with a plough make use of the guiding member through-slot to check plough's horizontal displacement. To re-adjust the turn-buckle brace for fitting them in the slots, remove the gib-and-cotter, turn the guiding member through 90° and insert the gib-and-cotter into the sliding block hole through the slot on the guiding member.

IMPORTANT! To ensure normal operation of the tractor-and-plough combination, the gib-and-cotter in the right-hand and left-hand braces should be in the middle of the slot in the guiding member.

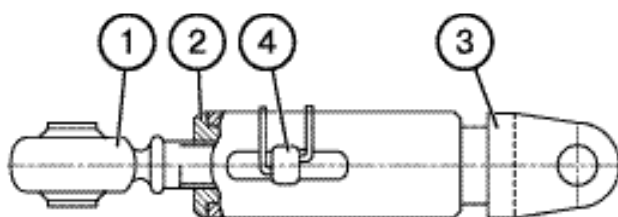

1 – screw; 2 – guide; 3 – slide block; 4 – gib-and-cotter.

UNIVERSAL HAUL-AND-DRAW COUPLER (HDC)

The lift-type HDC comprises a clevis as well as (optionally) drawbar and “Python”-type facility.

Clevis (TCY-3B)

The coupler is intended for operation with single-axle and tandem-axle trailers. It consists of a traction clevis (1) with a coupling pin, and a body (2). The traction clevis body is connected with the bracket (4) by means of the pin (3). The traction clevis position can be changed as to height by moving it over the guides in the bracket (4) and fixed by means of the pin (3).

Pull-Bar Mechanism (tow bar HDC-1M-01)

It is intended for coupling the tractor with heavy trailed and semi-trailed machines. It consists of a bearing support (5) and drawbar (6) connected with the support by means of the axle (7).

The draw-bar (6) is adjustable to dimensions of 400 and 500 mm between the PTO end-face and the point of attachment of the shackle of the trailer by reinsertion of the axle (7) into holes in the draw-bar (6).

“Python” Type Arrangement (TCY-2P)

It is used to operate the tractor with semi-mounted agricultural machines and single-axle trailers. The arrangement (pos. 8) is installed in the guides of the bracket (4) and fastened by bolts (9). To attach a trailer, it is necessary to pull out the pin (10), put the trailer’s coupling shackle on the thrust journal (8) and refit the coupling pin to guard against spontaneous disconnection of the trailer’s shackle.

IMPORTANT! The "Python" arrangement can be only used after the draw-bar (6) has been dismantled.

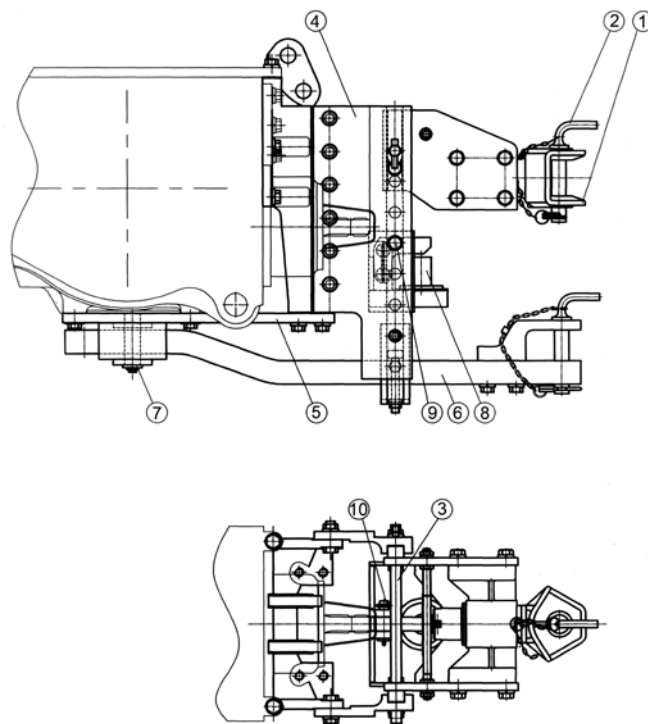

1 – drawbar clevis with coupling pin; 2 – coupling pin; 3 – pin; 4 – bracket; 5 – bearing support; 6 – drawbar; 7 – pin; 8 – “Python” arrangement; 9 – bolts; 10 – pin.

FRONT-END HITCH LINKAGE (FHL) (if installed)

The FHL is intended for operation of the tractor in combined aggregates and serves for coupling the tractor with

mounted agricultural machines intended for operation in front of the tractor as well as for adjusting their working position.

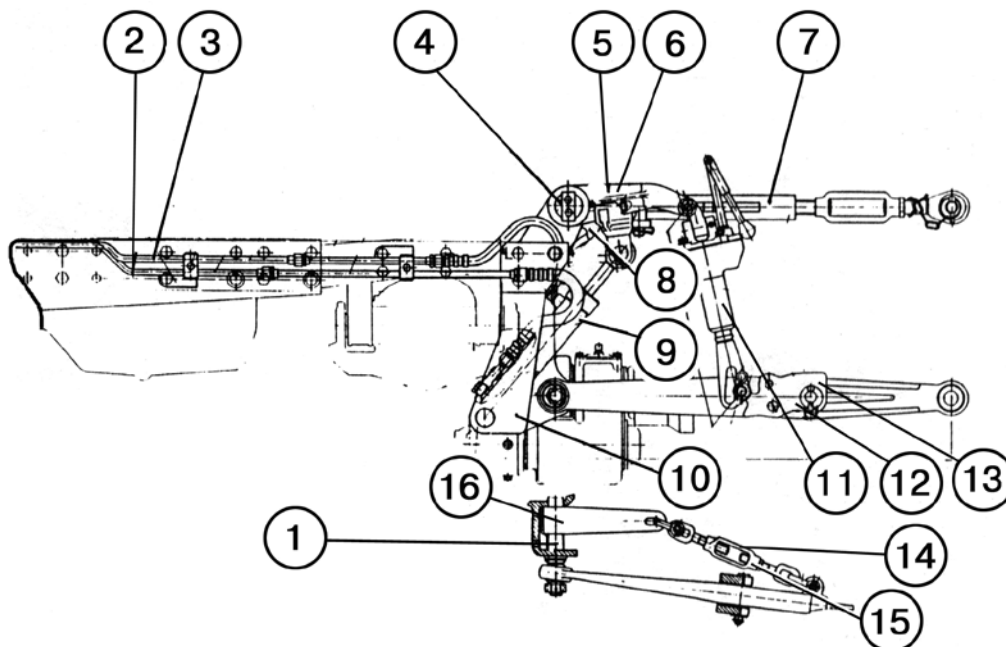

1 – axle of lower link; 2, 3 – oil pipelines; 4 – turn shaft; 5, 6 – levers; 7 – top link; 8 – lever; 9 – hydraulic cylinder; 10 – bracket; 11 – drop-link; 12, 13 – lower link; 14, 15 – turn-buckle braces; 16 – bracket.

The tractor equipped with a FRL can be delivered with a front independent power take-of shaft installed on the bracket front plane.

Attachment of agricultural machines to the FRL is identical to mounting on the rear hitch linkage.

The FHL is fitted with a mechanism for restriction of the lower link joints downwards when performing works with agricultural machines.

The FHL is installed on the front beam plane and attached with plates to the frame girders and side surface of the beam. The oil pipelines (2, 3) connect the side outlets (1) located on the right-hand side as seen in the direction of tractor travel, with the hydraulic cylinders (9) of the hitch linkage.

The double-acting cylinders are attached to the bracket (10) on one side and connected through their rods to the turn levers (5, 6) splined to the turn shaft (4). The turn levers are connected to the lower links (12, 13) of the hitch linkage by means of drop-links (11). The lower links are installed of shaft (1) which is passed through the bracket (10). Brackets (16) are also installed on the same shaft and connected to the lower link through turn-buckle braces (14, 15).

The lever (8) of the drop restriction mechanism is fitted on the turn shaft. In the working position, the drop restriction mechanism bears on a pin inserted into the bracket (10).

The top link (7) is connected to the lever (8) from one end and to the agricultural machine from the other end.

SYSTEM OF VENTILATION AND HEATING OF THE CAB

The cab ventilation and heating system consists of a fan with motor and radiator as well as four air cleaning filters. The fan and radiator are installed on the cab roof.

To ensure the effective performance of the ventilation and heating system, keep closely to the following recommendations:

1. After filling the cooling system with coolant (water), start the engine and, without opening the tap (1) located on the left-hand side of the engine, let the engine run at medium speed to warm-up the coolant in the system to about 50-60°C, then open the valve to prime the heater radiator.
2. Make sure that the fluid is circulating freely through the heater; to do this, open the drain plug (4) on the right-side of the cab. The heater radiator shall begin warming up; therewith, the level of coolant in the engine radiator shall drop.
3. Top up the water radiator with coolant to the level of the upper filler neck.
4. To speed up the warming-up of the cab, set the heater fan switch (3) to the ON position, and open the air-recirculation shutters (2).
5. To drain coolant from the heater and the engine cooling system, drive the tractor onto a level ground, open the heater tap (1), remove the engine radiator cap, the right- and left-hand drain plugs (4) and open drain taps on the water radiator and the engine cylinder block.
6. In the warm season, the tap (1) shall be closed for providing the operation of the system in the ventilation mode.

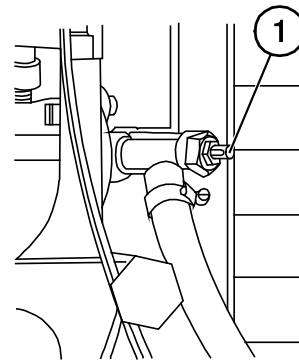

1 – tap

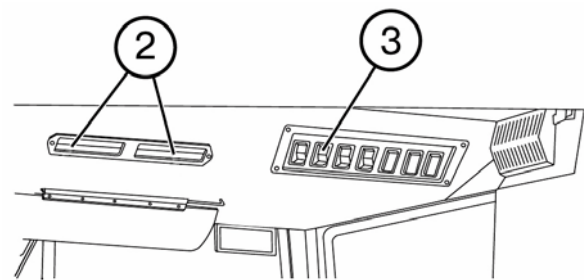

2 – air-recirculation shutters
3 – heater switch

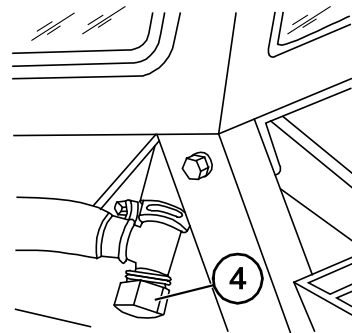

4 – draining plug

ATTENTION! To avoid formation of ice plugs in cold season, blow down the heating system with compressed air by closing preliminarily the water drain taps on the engine radiator and the cylinder block, with the radiator filler cap refitted.

AIR CONDITIONING AND CAB HEATING SYSTEM

Control of the climatic control system in the air-conditioning mode

The control panel of the climatic control system is located at the centre of the upper panel of the cab. The control panel comprises the switches (1) and (2):

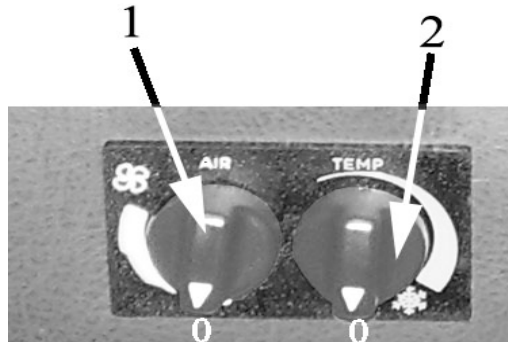

The switch (1) can be used for varying the air flow rate by varying the rotational speed of the fan. The switch (2) can be used for varying the temperature of cold and dried air escaping from the deflectors in the air conditioning mode.

ATTENTION: The air conditioner can be only switched on and operated when the engine is running.

To switch on the air conditioner, proceed as follows:

- Turn the switch (2) clockwise at the angle of 180° to the beginning of the blue scale;
- Then turn the switch (1) to one of the three designated positions (the fan rotor

has three rotational speeds). After 3-5 minutes adjust the desired temperature in the cab by means of the switch (2);

- The shutters located on the upper panel near the operator's head can be used for controlling the mixture of outer and recirculation air;

To switch off the air conditioner, it is necessary to turn both switches (1) and (2) counter-clockwise to the "0" position.

ATTENTION: during the operation in the cooling mode, the heater tap shall be closed to prevent the simultaneous operation of the systems of heating and air cooling.

Control of the climatic control system in the heating mode

ATTENTION: the engine cooling system shall be only filled with coolant with low freezing point.

To ensure the efficient operation of the heating system, observe the following recommendations:

1. After filling the cooling system with coolant, start the engine and let it run at medium speed without opening the tap

so that the coolant in the cooling system would be warmed up to 70-80°C, then open the top, increase the rotational speed of the engine and let it run for 1-2 minutes until the heater radiator is filled with coolant. Make sure that the coolant circulates through the heater. The temperature of the heater radiator shall rise. At the same time, the coolant level in the radiator of the engine cooling system will be lowered;

2. Add coolant to the radiator of the engine cooling system to the necessary level (to the MAX mark on the expansion bottle);

3. To speed up the warming-up of the cab, switch on the heater fan and open the recirculation shutters;

4. To drain the coolant from the heater and engine cooling system place the tractor on a level ground. Remove

the cap of the expansion bottle of the engine cooling system, cylinder block and disconnect the heater hose from the tap.

ATTENTION: during the operation in the heating mode, the switch (2) shall be fully set to the off position to prevent the simultaneous operation of the systems of heating and air cooling.

General Arrangement and Operation of the Air Conditioning and Cab Heating System

The air conditioning and cab heating system is intended for creating and maintaining the normal microclimate in the tractor cab. The air conditioning system consists of two circuits, the cooling and heating ones. The schematic diagram of the system is given below.

The cooling circuit includes the compressor, condenser, drying filter with the pressure sensor, monoblock of the

evaporator and radiator of the heater (cooler-heater), fan of the cooler-heater, connecting hoses with the complete set of quick-release couplings, electric cables, air filters, cold air control and fan switch. The heating circuit is supplemented with the hoses connected with the tractor engine cooling system and cooler-heater.

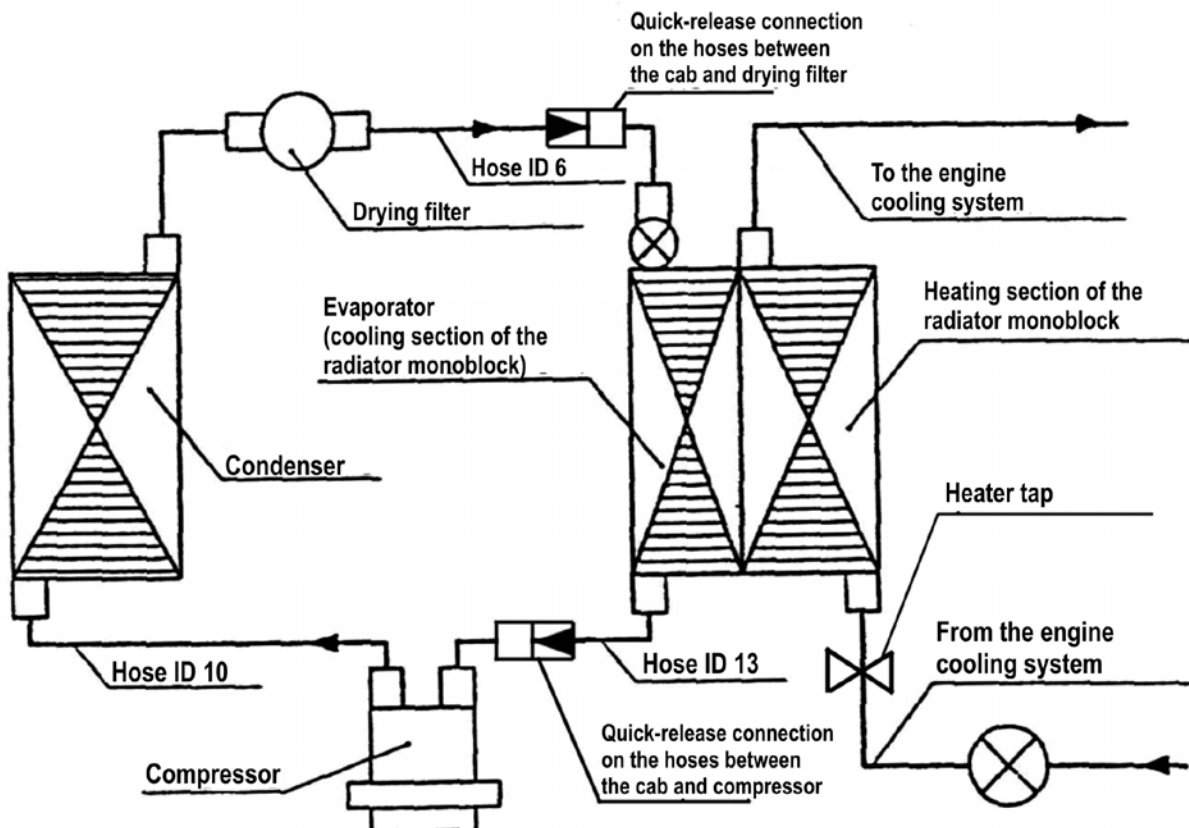

The components of the air conditioning system are arranged as follows:

- compressor – on the left of the semiframe, at the bottom;

- condenser – before the OHB radiator;
- drying filter – on the condenser frame;
- pressure sensor – on the drying filter;
- heater-cooler – under the roof, above the ventilation compartment panel;
- cold air control and fan switch – on the panel of the upper compartment;
- service valves – on the fittings near the compressor and drying filter.

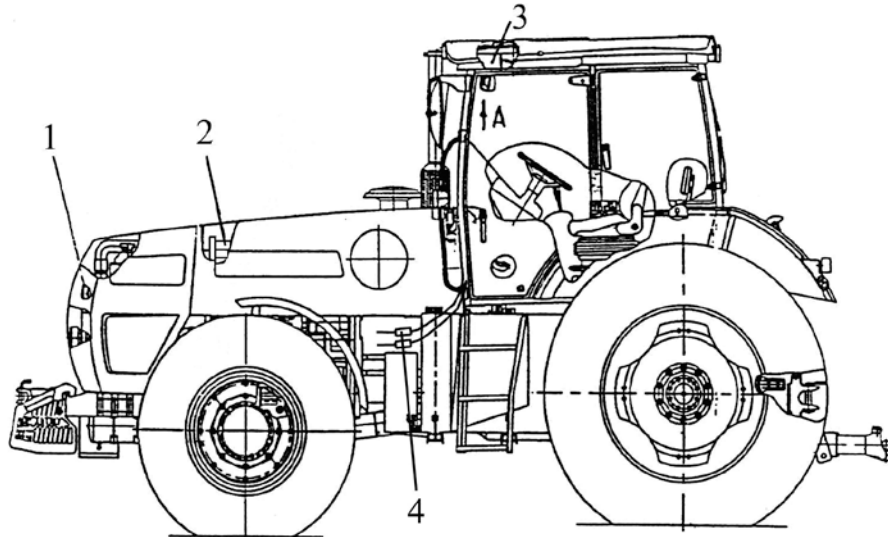

1 – condenser and drying filter; 2 – compressor; 3 – cooler-heater; 4 – quick-release connectors.

The climatic-control system begins functioning in the air conditioning mode when the engine is running, the desired rotational speed of the fan is set by means of the switch (1) and the switch (2) is set to the beginning of the blue scale.

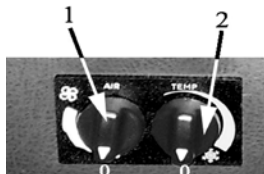

When it will be done, the voltage is applied to the electromagnetic clutch of the compressor via control circuit. The clutch is engaged to transmit the rotation from the engine crankshaft pulley to the compressor shaft. The compressor pumps the coolant through the air conditioning system components. At the same time, the coolant absorbs the heat from the air passed through the evaporator-radiator monoblock (air cooler-heater) and then releases the heat into the environment via condenser.

The air conditioning system is capable of maintaining automatically the specified temperature, which is set by turning the switch (2) controlling the thermostat. When turning the switch clockwise, the temperature decreases and when turning the same anti-clockwise – increases. The protection against critical modes is ensured by the pressure sensor and thermostat. The sensor switches the system off in case of overpressure (exceeding $26+2 \text{ kg/cm}^2$) or insufficient pressure (below $2.1\pm 0.3 \text{ kg/cm}^2$). The thermostat switches the system off in case of excessive decrease of the temperature of the cooling section of the radiator monoblock. The system capacity is controlled by means of the fan rotational speed and thermostat. In this case the compressor can be operated either continuously or cyclically.

The main parameters and technical characteristics of the air conditioning and cab heating system are given in the table below:

Description of the parameter (characteristic)	Value
Cold productivity, kW	6.4
Heat productivity, kW	8.7
Operating voltage, V	12
Electrical power consumption, W	260
Mechanical power consumption, kW	1.4 to 8.0
Coolant	R134a, ozone-saving
Compressor	DELPHI SP15
Compressor drive belt	SPA/S-1650

To maintain the system in the serviceable condition in case of non-regular operation, it is recommended to switch on the system in the cooling mode once 15 days in the cooling mode (at the outer temperature exceeding 15°C) for 15-20 minutes.

Regardless the operating conditions, it is necessary to check the operation of the system at the service station using special equipment once a year.

When putting the tractor for short-term storage, no preparatory works should be performed for the air conditioning system. During the storage, it is necessary to switch on the air conditioner with the engine running for 15-20 minutes once 15 days. In this case, the

air temperature in the tractor cab shall not be below 20°C.

When putting the tractor for long-term storage, it is necessary to check the operation of the air conditioning system using special equipment once a year. If necessary, add coolant. During the storage, no service works should be performed.

When taking the tractor from the storage, it is necessary to perform the service of the air conditioning system at the specialized service station using the diagnostic equipment.

Other information on the maintenance and servicing of the air conditioning and cab heating system are given in the Section "Scheduled Maintenance".

WARNINGS:

1. Only the specially trained personnel shall be allowed to perform the maintenance and repair of the air conditioning system components.
2. Any works related to uncoupling of the air conditioning system components shall be performed by the training personnel using special equipment for maintaining the air conditioners. The system contains high pressure even in inactive state.
3. Prior to stopping the tractor engine, make sure that the air conditioner is off.
4. The r134a coolant is neither toxic, nor flammable. It does not form explosive mixtures. The coolant boiling temperature under normal conditions is minus 27°C. If the liquid

coolant gets in contact with the skin, it evaporates instantly and can cause the frostbite of the exposed areas of the skin.

5. When unhitching the tractor, it is allowed to uncouple the closed air-conditioning system by disconnecting the quick-release couplings.

ELECTRIC EQUIPMENT

NOTE: The electric connection diagram of the tractor is provided in the section "Appendices".

The tractor is provided with DC electrical equipment, with 12-volt on-board systems. To start the engine after setting the storage battery remote-control switch to the ON position, the voltage of 24 V is applied to the starter from two 12-V storage batteries of 12-volt each.

The electrical equipment consists of electric power sources, engine starting means, measuring instruments, lighting devices, light and audible signalling as well as switching and auxiliary equipment. The electrical devices are wired in a single-wire system so that the metallic parts of the tractor ("frame earth") function as the second wire to which the negative terminals of all electric devices are connected.

The electric power sources of the tractor are two storage batteries each with the voltage of 12 V and capacity of 120 A•h and alternator. The rated voltage of the alternator is 14 V and its rated power is 1150 W (for the engine Д-260.1) and 2000 W (for the engine Д-260.1S2).

The engine start system consists of a 24 V, 5.1 kW electric starter with remote switching on, starter and instrumentation switch, starter control unit and starter relay. To ensure the engine start at low temperatures, the start assisting facilities

with a control unit and relay for heating air, which is sucked into the engine cylinders, are provided.

The illumination, light and audible signalling devices include two headlights with high and low beams, four front and four rear working floodlights, front turn indicators and marker lights, tail markers, stop-light and rear turn indicators, number-plate illumination light, cab light, fault signalling emergency switch, "road train" sign light, horn and a set of horn-type signals, steering column-mounted handle-switches, and relays to energize corresponding instruments.

The operation of the tractor systems is controlled by means of:

- the instrument cluster including an indicator of the air pressure in the pneumatic system with an emergency pressure lamp, a gearbox oil pressure gauge, an engine lubrication system oil pressure gauge with an emergency pressure lamp, an indicator of the coolant temperature in the engine cooling system with an emergency temperature lamp, a fuel tank level gauge with a warning lamp of reserve level, and an electric system voltage indicator with an auxiliary storage battery charge lamp;
- pilot lamp block;
- combined indicator with the control panel;

- audible signalling (buzzer) of emergency conditions: emergency oil pressure in the engine lubrication system, emergency coolant temperature in the engine cooling system.

The purposes and functions of the instruments included in the instrument cluster as well as combined indicator together with the control panel and pilot lamp block are described in Section 4 "Drive Controls and Instruments".

The sensors of the instruments and emergency indicators and monitors of serviceability of tractor assemblies and systems include:

- Sensor of the indicator of the coolant temperature in the engine cooling system;
- Sensor of the indicator of the emergency engine coolant temperature;
- Gauge of the oil pressure in the engine lubrication system;
- Sensor of the emergency oil pressure in the engine;
- Sensor of the engine air cleaner clogging;
- Sensor of the air pressure in the pneumatic system;
- Sensor of the emergency air pressure in the pneumatic system;
- Interrupter of the warning lamp of application of the parking brake;
- Fuel level gauge sensor;
- turn indicator interrupter;
- Sensor of the emergency level of brake fluid;
- Sensor of emergency oil pressure in the HPS;
- Gearbox oil pressure gauge;
- Stop-light switches.

To obtain information on the performance parameters of the tractor, rear wheels rotational frequency indicators and a signal from the alternator phase winding are used.

The engine start interlock switch serves for preventing the engine starting with a gear engaged.

The auxiliary equipment includes:

- Electric motor in the cab ventilation and heating system with its switch;
- Electric wiper of the windscreen;
- Electric wiper of the rear screen;
- Windscreen washer.

The electric equipment schematic diagram provides for installation of an air conditioner together with its relay, sensor and thermostat as well as of a radio-tape recorder and loudspeakers.

The electric power consumers and their respective circuits are protected by fuses.

TRACTOR PRE-OPERATION

GENERAL REQUIREMENTS

Prior to putting a new tractor into service, perform the following procedures:

- wash the tractor;
- make a thorough inspection of the tractor, check the completeness of its sets and units; remove the storage batteries, make them ready for operation, and place them back into their place;
- check the threaded connections for tightening and, if necessary, retighten them;
- check the oil level in the engine crankcase, power transmission housing, FDA casing, hub drive reduction gear boxes, hydraulic system and HPS oil tanks and replenish oil, if necessary.
- drain all fuel from the fuel tanks and fill the fuel tanks with fresh settled fuel: in winter – with that of winter grade, in summer – with that of summer grade;
- check the brake fluid levels in the master cylinders of hydrostatic actuators of the clutch and service brakes; replenish, if necessary.
- fill in the engine cooling system with coolant to the upper end-face of the radiator filler neck;
- check and adjust as necessary the tension of the alternator drive belt;
- lubricate the tractor mechanisms and assemblies in accordance with Appendix 11.8;
- check the air pressure in the tyres and bring it to the normal value, if required.

CAUTION! Prior to putting the tractor into operation, make sure that the protective enclosures are in place (rear PTO shaft-end enclosure, etc.)

- Apply the parking brake of the tractor;
- Open the fuel tank cock;
- Prime the fuel-feeding system with fuel and bleed air therefrom;
- Set the fuel feed control lever to its middle position, and the PTO control lever to the “Brake” position;
- Set the gearshift and gearbox range levers to their neutral positions;
- Set the battery disconnect switch to the ON position.

ATTENTION! Start the engine from the operator’s working seat only.

IMPORTANT! Never start the engine unless its cooling system is filled with coolant.

- Turn the starter switch to the “I” position (fixed). Therewith, the following pilot lamps light up: those of the glow plugs and HPS emergency oil pressure in the pilot lamps cluster; and the warning light of emergency engine oil pressure (a buzzer signal sounds), air pressure indicator (if the it is lower than that admissible one), voltage indicator and the fuel level indicator (if fuel in tanks is at a reserve level) in the combined instrument cluster dial;

PROCEDURE OF PRE-STARTING AND STARTING THE ENGINE

Start-Up Under Normal Conditions

- As soon as the glow plug pilot lamp starts flashing, turn the starter switch key into "II" position. As this takes place, an engine start pilot lamp lights up (amber). Should the starter fail to start with the key turned into "II" position, and the pilot lamp is running in a flashing mode at low frequency (about 1.5 Hz), it means that the GB handle is not in the neutral position or, possibly, the engine start interlock circuit is open. Blinking of the pilot lamp at higher frequency (about 3 Hz) signals about a fault in the phase winding of the alternator ("W" terminal).

Hold the key in the II position until the engine starts, but no longer than for 15 s. If the engine fails to start, repeat the procedure after not less than 30...40 s. If the engine would not start after three attempts of starting, then locate and eliminate the trouble.

- With the engine running, check all the pilot lamps for proper operation and instrument readings (coolant temperature, oil pressure in the engine and the GB, storage batteries charging, etc.). Let the engine run at 1000 rpm until the pressure is stabilized within the operating range.

IMPORTANT! Your tractor is equipped with a turbocharged engine. The operation of the turbocharger at high rotational speed requires reliable lubrication when starting the engine. When starting the engine for the first time or after a long-term storage, resort to cranking the shaft by the starter for about 10 s with the fuel feed shut off to ensure the lubrication of the turbocharger bearings. Let the engine run idling for 2...3 min before putting it under load.

Starting the Engine at Low Temperatures (+4°C or below)

IMPORTANT! To avoid any damage in the power train, never push or pull the tractor to start the engine by towing.

- Turn the starter switch key to its "I" position (i.e., the glow plugs). As this takes place, the pilot lamp on the pilot lamp block lights up to signal that the glow plugs are ON.
- Hold the key in this position. When the lamp starts flickering, the engine is ready for starting up;
- Turn the starter key to its "II" position and follow the above instructions for the engine start procedure under normal conditions. On starting the engine, the pilot lamp goes out and the audible signalling turns off.

To start the engine at ambient temperatures below minus 20°C, it is a good practice to use a special circulatory heater for coolant in conjunction with starting the preheating means.

The installation of the circulatory heater is shown in the figure.

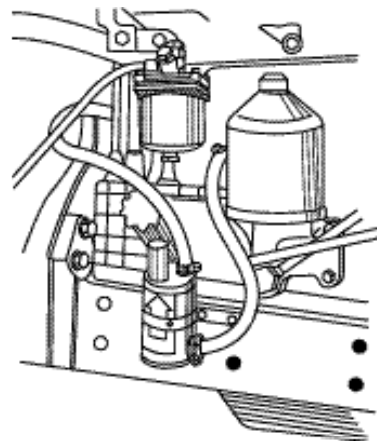

NOTE: The circulatory heater of coolant should only be used for cooling circuits filled up with antifreeze.

At settled low temperatures, use winter-grade oils (if no winter-grade motor oil is available, the use of a mixture of summer

motor oil with 10-12% of diesel fuel is permitted) in the engine crankcase, transmission, hydraulic system and HPS, following the instructions of this Manual. Always keep the storage batteries fully charged.

Use clean winter-grade diesel fuel with no admixture of water. To avoid faults, drain the sludge from the fuel gravitation-filter and fuel tanks on a daily basis.

IMPORTANT! To exclude the possibility of condensate forming inside the tanks, refill the fuel tanks at the end of each working day.

ATTENTION! The tractor is equipped with a single seat. DO NOT admit outsiders to the cab when operating the tractor.

GETTING THE TRACTOR MOVING AND DRIVING THE TRACTOR

Belarus 1523/1523B (КП 16F+8R)

To bring the tractor in motion, proceed as follows:

- slow down the engine;
- step on the clutch pedal as far as it will go and select a required GB speed range; to do this:
 - move the lever (1) to its rightmost (spring-loaded) position and pull or push it to select the I (lowest) or II (highest) speed range, respectively;
 - return the lever to the neutral ("N") position and further move it to the left to choose the required speed in accordance with shift pattern diagram I;
 - choose the required gear by means of the lever (2) in accordance with shift pattern diagram II;
 - release the parking brake and ease up the clutch pedal smoothly while increasing simultaneously the engine rotational speed. The tractor will start to move.

IMPORTANT! To shift in the gear smoothly (without abrupt jerks), move the gear-shift lever (2) in accordance with diagram II and hold it in this position with slight pressure until the gear is in full mesh.

ATTENTION! Prior to setting the required speed range or to shifting in the gear in the GB, make sure that you have stepped on the clutch pedal.

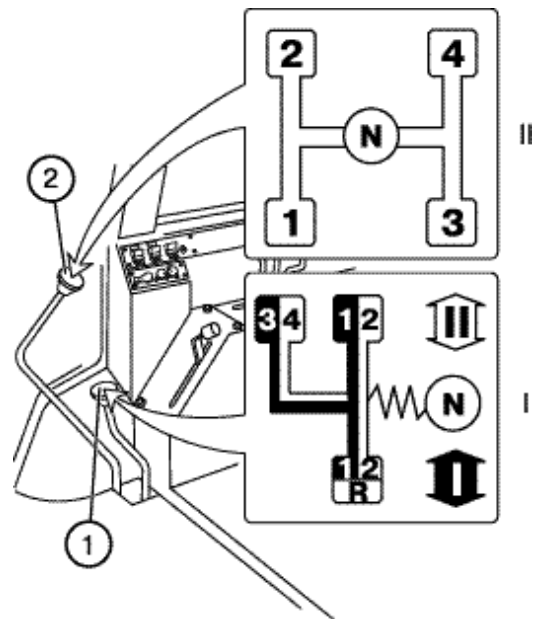

IMPORTANT! To avoid noisy change-over, shift the range select lever (1) when the tractor is at complete standstill only. When driving the tractor, DO NOT keep your foot on the clutch pedal, since this would cause clutch slippage, its overheating and failure.

Starting movement with high traction load (e.g., with a plough deep in soil) should be avoided. With the gear in mesh, release the parking brake and ease off on the clutch pedal. With the tractor moving off, smoothly increase fuel supply.

BELARUS-1523.3/1523B.3 (GB 24F+12R)

To bring the tractor in motion, proceed as follows:

- slow down the engine;
- step on the clutch pedal as far as it will go and select a required GB speed range; to do this:
 - move the lever (4) to one of the following positions: “A”, “B” or “R”, in accordance with range selection pattern diagram I;
 - press the pushbutton (1) to engage the lowest stage (L) of the GB reduction gear or the pushbutton (2) to switch on highest stage (H) of the GB reduction gear;
 - choose the required gear by shifting the speed lever (3) from its neutral “N” to one of the following positions: 1, 2, 3, 4, 5, 6 in accordance with shift pattern diagram “II”;
 - release the parking brake and ease up the clutch pedal smoothly while increasing simultaneously the engine rotational speed. The tractor will start to move.

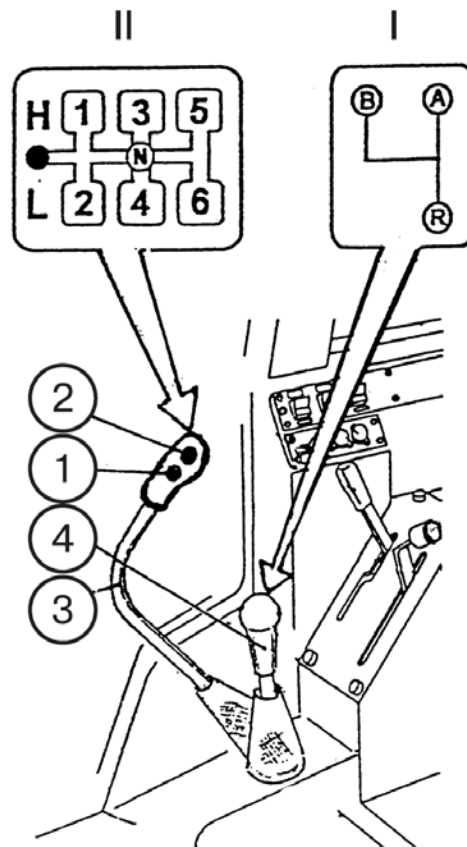

IMPORTANT! To avoid noisy change-over, shift the range select lever (4) when the tractor is at complete standstill only. When driving the tractor, DO NOT keep your foot on the clutch pedal, since this would cause clutch slippage, its overheating and failure.

IMPORTANT! The engagement of the reduction gear stages “L” or “H” is only possible when the gear-shift lever (3) is placed to its neutral position.

IMPORTANT! To shift in the gear smoothly (without abrupt jerks), move the gear-shift lever (3) in accordance with diagram II and hold it in this position with slight pressure until the gear is in full mesh.

ATTENTION! Prior to setting the required speed range or to shifting in the gear in the GB, make sure that you have stepped on the clutch pedal.

STOPPING THE TRACTOR

To stop the tractor, proceed as follows:

- lower engine crankshaft rotational speed;
- step on the clutch pedal as far as it will go;
- set the gear-shift lever and the range-shift lever into their neutral position;
- release the clutch pedal;
- stop the tractor using service brakes;
- apply the parking.

ATTENTION! To stop the tractor in an emergency situation, step sharply on both clutch and brake pedals.

Stopping the engine

IMPORTANT! Prior to stopping the engine, lower the attached agricultural implement on the ground and let the engine run at 1000 rpm for 3...5 min.; this allows the diesel coolant temperature to be reduced.

To stop the engine:

- put the fuel feed control lever to the rearmost position (corresponding to engine minimum idling rotational speed);
- pull the engine stop handle as far as it will go and hold it in this position until the engine fully stops;
- disengage the PTO;
- put all the distributor-valve handles to the neutral position;
- lower the mounted machine onto the ground;
- place the SB switch to its OFF position to avoid the discharge of the storage batteries.

RUNNING-IN

IMPORTANT! The first 30 hours of operation of the tractor affect strongly the further performance and service life of the tractor, especially as regards its engine.

Your new tractor will work reliably and for extended period of time, given proper running-in procedure and the required service operations carried out on time as recommended.

ATTENTION! For the first 15 hours of running-in operation, the tractor should be used on light-duty haulage jobs, while the rest of time – on light-duty field work involving the use of the hydraulic lift linkage (HLL).

During the 30-hour running-in period, observe the follows safety precautions:

1. Keep a constant watch over the readings of the instruments of the lubrication, cooling, and feed system. Monitor the level of oil and of other fluids in the tanks and bottles.
2. Check the external connections and joints for tightening; retighten them, if required.
3. Neither overload the engine, nor allow the engine to run with smoky exhaust

or drop in the rotational speed. The signs of overloading are as follows: sharp drop in the rotational speed, fumes and failure of the engine to respond to the fuel-feed boost. Operation under load in higher gear causes excessive wear of engine rubbing parts.

4. Operation of the tractor at low load, in a too low gear, but at high rotational speed of the engine may result in excessive fuel consumption. The correct choice of gearing for specific condition of operation saves fuel and reduces the wear of the engine rubbing parts.
5. Avoid extended periods of operation of the tractor under no-load conditions at maximum or minimum rotational speed of the engine crankshaft.
6. To ensure the correct break-in of the rubbing parts of the clutch in the running-in process, smoothly engage and disengage the clutch more frequently.
7. Perform regularly the daily maintenance in conformity with the recommendations specified in Section 9 "Scheduled Maintenance" of this Operation and Service Manual.
8. Clean the coarse oil filter after 10 hours of running-in of the tractor.

POST-RUNNING-IN MAINTENANCE (30 hours of operation)

1. Inspect and wash the tractor.
2. Listen to all tractor units and components for normal running.
3. Check the tightening torque of the bolts attaching the cylinder head. Retighten them, if necessary.
4. Check the valve stem-to-rocker arm clearances. Readjust them, if necessary.
5. Clean the engine and gear-box centrifuge rotors.
6. Clean the gear-box screen filter.
7. Check tension of the alternator driving belt. Readjust, if necessary.
8. Drain sludge from the engine fuel tanks, coarse and fine filters.
9. Check and adjust, if necessary, the free travel of the clutch and brake pedals, and the pneumatic system.
10. Check the storage battery condition; clean the terminal connections and vent holes.
11. Change oil in:
 - the engine crankcase;
 - transmission;
 - the front PTO reduction-gear box (if installed);
 - hub reduction-gear boxes and the FDA beam casing;
12. Change the paper filtering elements of the engine oil filter.
13. Grease the clutch disengaging bearing.
14. Drain condensate from the pneumatic system receiver-bottles.
15. Check and restore, if necessary, the tightness of the air-cleaner and the air intake duct.
16. Check the functioning of the engine, steering control, brakes, driving controls, lighting and signalling systems.
17. Gun-grease all the lubrication points.

Note: Performing these operations is described in the section “Scheduled Maintenance”.

AGGREGATING THE TRACTOR WITH AGRICULTURAL MACHINES AND IMPLEMENTS

General information provided in this Section will help to use efficiently the BELARUS 1523/1523B/1523.3/1523B.3 with a great variety of machines and implements (hereinafter referred to as the machines or technical facilities) to be used in the agriculture.

Aggregating the tractors with other machines involves a complex of operations related to selection of machines, determination of feasibility and techniques of attaching the machines to the tractor, with the tuning and adjustment of units and mechanisms of all the components of a machine-tractor aggregate (MTA).

As regards the method of ganging (aggregating) with tractors, all the agricultural machines (implements) are classified as follows:

- **The tractor-mounted** ones are to be attached to the tractor's three-point hitch linkage. The machine weight in the transport position is fully transferred to the tractor.
- **The semi-mounted** ones are to be attached to the three-point hitch linkage run on supporting wheels. The machine weight in the transport position is partly transferred onto the tractor and partly is supported by the wheels of its own. When rearranging the machine from the working position to the transportation one, the point of attachment to the tractor is forcedly shifted to a new position as to height.
- **The semi-trailed** ones are to be attached in the same way as the semi-mounted are, but when rearranging the machine from the working position to the transportation one, the point of attachment to the tractor does not change its position as to height.
- **The trailed** ones are to be attached to the haul-and-draw coupling arrangement of the tractor. The machine

weight is carried by its own running gear. When rearranging the machine from the working position to the transportation one, the point of attachment to the tractor does not change its position as to height.

- **The fitted** ones are to be attached to the tractor by means of additional assembly units using the mounting holes available on the tractor. The machine weight is fully taken by the tractor. Installation of fitted machines shall be only done subject to the approval of the Manufacturer. In case of installation of a machine unauthorized by the Manufacturer, all the consumers' claims and unsatisfactory equipment reports shall be sent to the entity which has installed and checked the equipment.

The Belarus tractors are equipped with various working equipment to be used for aggregating in standard and optional kits thus providing a means for coupling and joint operation of all the agricultural machines and implements which comply with tractor's hitch and/or haul-and-draw mounting dimensions and energy requirements. In addition, the provision of a power take-off shaft (PTO) and free outlets of the hydraulic system make it possible to drive tools of the attached machines/technical facilities by either mechanical or hydrostatic method.

This Section contains the information on the working equipment intended for aggregating with the tractor; the methodology of choosing the machines for aggregating with the above-stated tractors as well as admissible loads and speed regimes of the tractor when combined in a machine-tractor aggregate.

ADJUSTING THE WHEEL TRACK

Front Wheels

With the standard tyres
420/70R24

Wheel position	Wheel track, mm
A	1540
B	1635*
C	1850
D	1950
A'	1700
B'	180
C'	2020
D'	2090

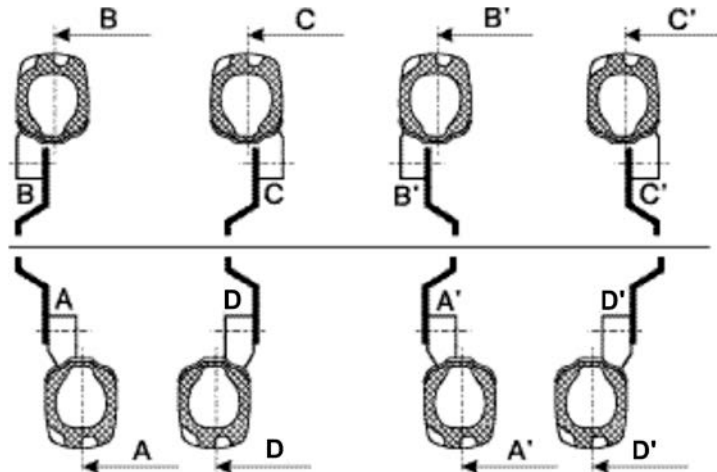

The positions of wheels with inverted disks (primed letters) should be only used in exceptional cases.

A, B, C, D: standard installation of the disk with a remounted rim;

A', B', C', D': re-arrangement of the disk and the rim.

* As shipped from the Manufacturer

Rear wheels

Tyre standard size	Wheel position	Wheel track width K, mm	Hub mounting dimension* H to half-axle end-face, mm
520/70R38	A	1600...1900	155...5
	C	1950...2440	245...0
18,4R38	A	1480...1900	215...5
	C	1950...2440	245...0

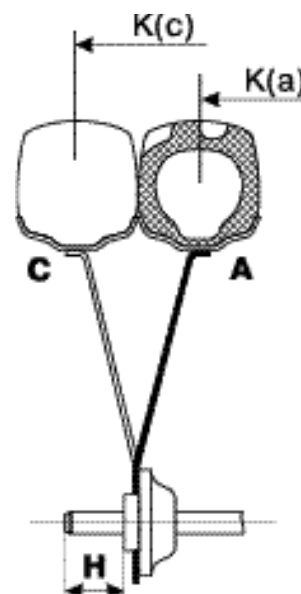

** Changing the wheel track by the amount of *n* corresponds to a shift in the hub position by *n*/2 from each side.

TWINNING THE REAR WHEELS TO REDUCE THE SPECIFIC PRESSURE OF THE GROUND

Tyre standard size in package	Wheel track width K_1, K_2 , mm	Hub mounting dimension H_1, H_2 , mm	Remarks
520/70R38 + + distance piece + + 520/70R38	$K_1 = 1500$ $K_2 = 2930$	$H_1 = 190$	Distance piece* 1522-3109020
18.4R38 + + 18.4R38	$K_1 = 1480$ $K_2 = 2440$	$H_1 = 215$ $H_2 = 0$	Paired hubs

* The distance piece 1522-3109020 intended for twinning the wheels from optional additional package can be used instead of hub pairing.

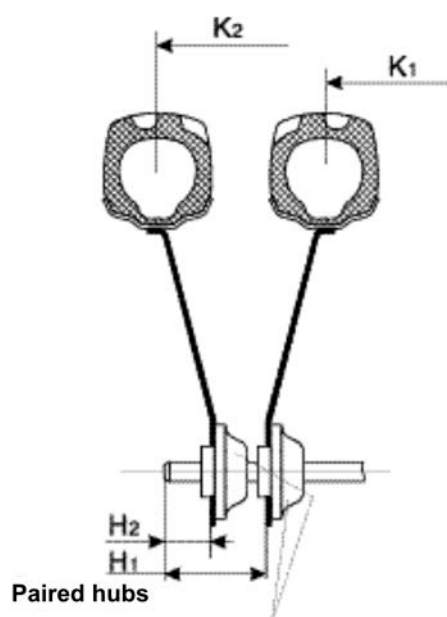

INTER-ROW CULTIVATION OF ROW CROPS ON TYRES OF STANDARD TYRE PACKAGE

Inter-row widths M, mm	Wheel track K, mm		Main row crops
	front	rear	
	420/70R24	520/70R38 18.4R38	
800	1540 (A)	1600	* Potato in drills, corn, cotton
900	1800 (B')	1800*	
1000	2020 (C')	2000	

Tyre parameters

Tyre standard size	Sectional width, mm	Static-load tyre radius, mm	Tyre package
420/70R24	420	569	standard
520/70R38	520	795	
18.4R38	467	805	additional
11.2R24	284	567	
11.2R42	284	745	

Protective Margins for the Tractor Wheels during the Row-Crop Cultivation

Basic crops	Protective margin, mm
Beet	80
Corn	120
Potato in drills	200
Cotton	200

HITCH AND HAUL-AND-DRAW COUPLERS

Rear Hitch Linkage

For machines: mounted and semi-mounted

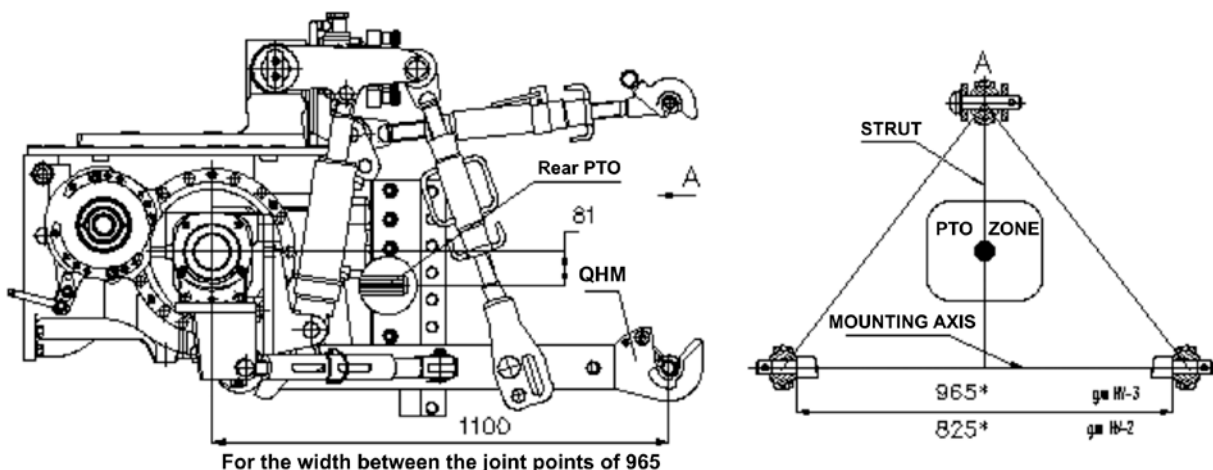

Type of hitch arrangement (category)		HY-3 (Cat. 3)	HY-2 (Cat. 2)
Lower links		One-piece, with QHM ***	
Lower link length, mm		1060	
Hinge width, mm	of the top link	51	
	of the lower links	45	
Nominal diameter of coupling elements, mm	pin of the top link	Ø32	Ø25
	hinges of the lower links	Ø37	Ø28
Distance from the PTO end-face to the mounting axis, mm		668 (654**)	
Carrying capacity, kN	at the mounting axis	68	
	at the 610-mm overhang	45	
Machine support height *		685	610

* Dimensions attributed to the machine to be attached.

** PTO 3 tail-piece.

*** QHM – a quick-hitch mechanism with replaceable hinges, Cat. 3 and 2.

Front Hitch Linkage

For machines: mounted and semi-mounted

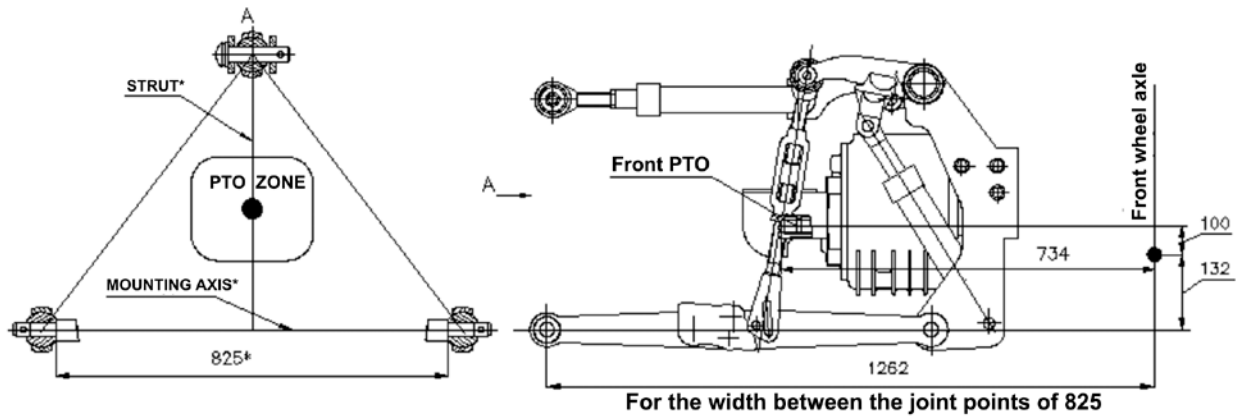

Type of hitch arrangement (category)		HY-2 (Cat. 2)
Lower links		Composite, with rolled-in hinges
Lower link length, mm		885
Hinge width, mm	of the top link	51
	of the lower links	45
Nominal diameter of coupling elements, mm	pin of the top link	025
	hinges of the lower links	028
Distance from the PTO end-face to the mounting axis, mm		550
Carrying capacity, kN	at the mounting axis	25
	at the 610-mm overhang	23
Machine support height *		610

* Dimensions attributed to the machine to be attached.

Haul-and-Draw Coupler TCY-1 (cross-bar)

For machines: semi-mounted (seed planters, potato planters, potato harvesters, vegetable harvesting machines, and others), semi-trailed (mowers, pickup bailers, root-vegetable top harvesters, fertilizer placers, etc.); trailed (disk harrows, soil cultivation units, stubble breakers, trains of coupled harrows, cultivators, seed planters, etc.).

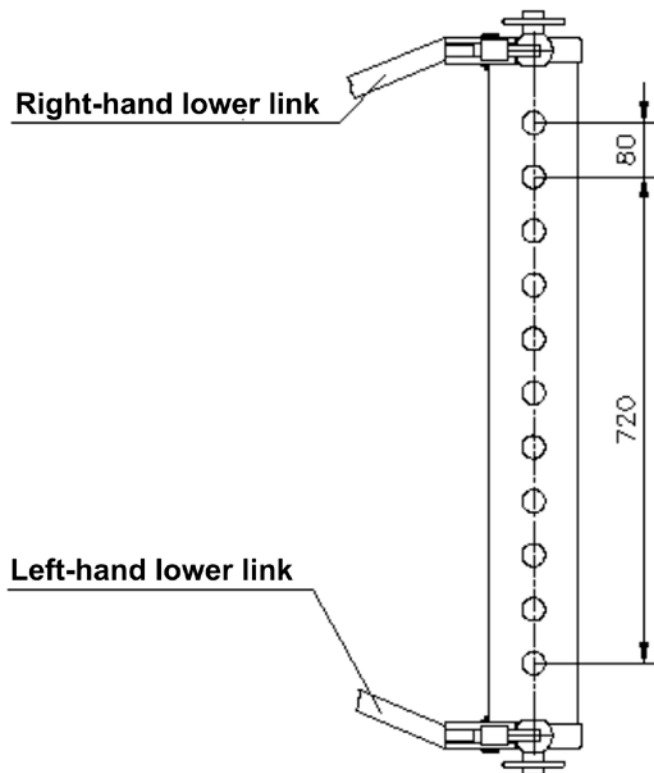

Hitch coupler type	TCY-1
	a crossbar at the mounting axis of the rear hitch linkage
Distance from the PTO end-face to the mounting axis, mm	668 (654*)
Coupling pin diameter, mm	Ø30
Vertical load on the TCY, kN	6,5

* PTO 3 tail piece.

ATTENTION!!

- The TCY-1 coupler is intended for joint operation with agricultural machinery **at a speed not exceeding 20 km/h and fitted with a hitch yoke of their own** to be attached to the crossbar.
- **Aggregating** the trailers and/or semitrailers (of special- or general-purpose) with the tractor by means of the TCY-1 coupler **is strictly prohibited**.

Lift Coupler

Purpose: to fasten the hitch and haul-and-draw couplers of appropriate coupling dimensions.

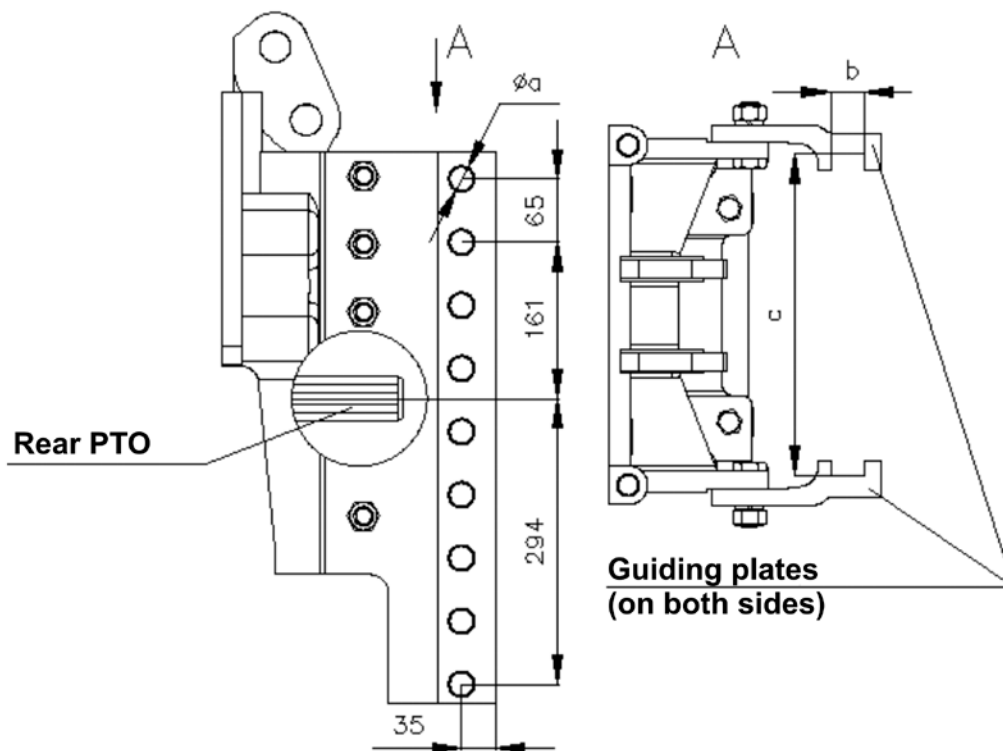

Lift coupler	Vertical guiding plates are made with holes		
Special features	Possibility of changing the position of hitch couplers as to height in 65-mm steps		
Version of make installed**	Version "1"	Version "2"	Version "3"
Hole diameter "a", mm	24		20
Slot width "b", mm	34		30
Dimension over slots "c", mm	330		
Distance from the PTO end-face to coupling holes axis of the guiding plates, mm	55 (41*)		

* PTO 3 tail piece.

** Version "1" is used in the standard kit. In Version "2" there is no top hole in the guiding plates.

Certified hitch couplers of other manufacturers make with suitable coupling dimensions may be used subject to mandatory adherence to permissible loads.

Haul-and-Draw Coupler TCY-2P

For machines: semi-trailed (semi-trailers, fertilizer placers, etc.); pull-type (disk harrows, soil cultivation units, trains of coupled harrows, cultivators, seed planters, etc.).

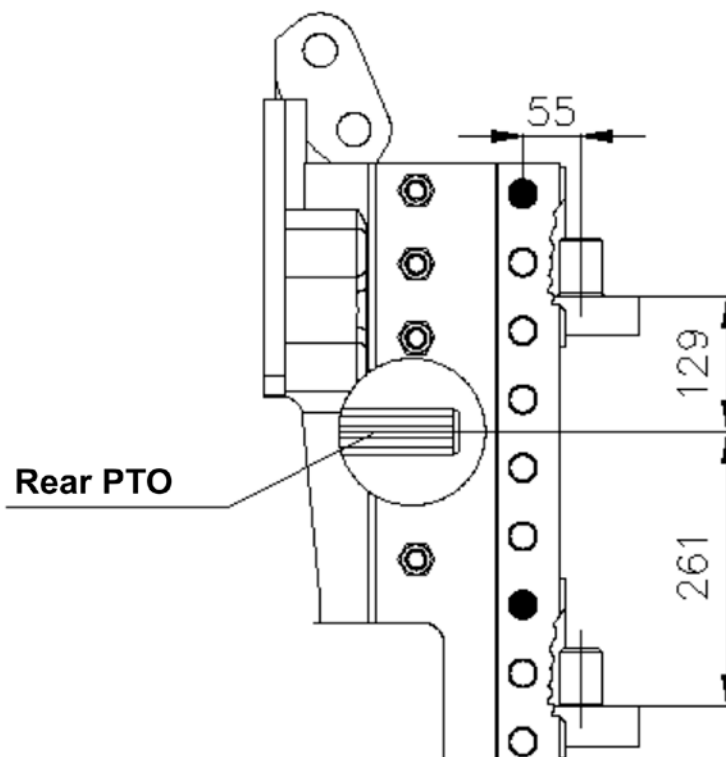

	Coupler TCY-2P (Python)
Type of the hitch coupler	Cantilevered pin, free to be relocated stepwise in the vertical plane with the increments of 65 mm.
Position of the yoke for PTO-driven machines	Below or above the PTO axis
Distance from the PTO end-face to the mounting axis, mm	110(96*)
Coupling pin diameter mm	Ø40
Vertical load on the coupler, kN	25

* PTO 3 tail piece.

ATTENTION! NEVER install the above coupler at the 1st and 2nd holes from the bottom.

Haul-and-Draw Coupler TCY-3B

For machines: pull-type (2-axle trailer of an automobile-type and others); semi-trailed (mowers, pick-up hay bailers, haulm removing machines, etc.).

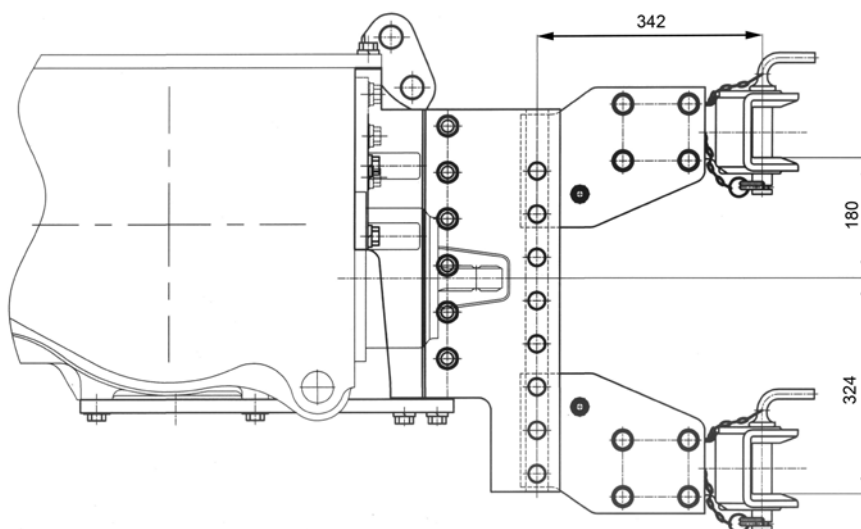

	Coupler TCY-3B
Type of the hitch coupler	a yoke with the possibility of step-wise displacement with increments of 65 mm
Position of the yoke for PTO-driven machines	below the PTO axis
Distance from the PTO end-face to the mounting axis, mm	400
Vertical load on the coupler, kN	12

* PTO 3 tail piece.

ATTENTION! NEVER install the above coupler at the 1st holes from the bottom.

Haul-and-Draw Coupler TCY-1M-01

For machines: semi-trailed (semi-trailers, fertilizer placers and the like); pull-type (disk harrows, soil cultivation units, trains of coupled harrows, cultivators, seed planters, etc.).

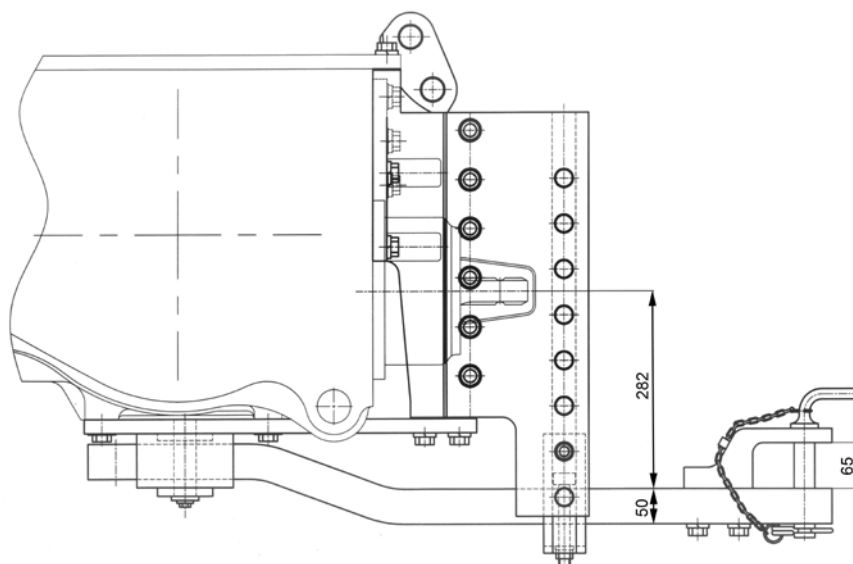

		Coupler TCY-1M-01	
Type of the hitch coupler	drawbar with the possibility of displacement in the horizontal plane with respect to the rear PTO end-face		
Distance from the PTO end-face to the mounting axis, mm	1st position	2nd position	
	400(386*)	500 (486*)	
Coupling pin diameter, mm	Ø30		
Vertical load on the HDL, kN	12	8	

* PTO 3 tail piece.

The rear hitch linkage HY-2(3) is made to Cat. 3, with a potential of being readjusted to Cat. 2 by replacing the independent joints of a quick-hitch mechanism (GHM). The provision of replaceable Cat. 3 and 2 joints makes it possible to carry out simple readjustments and to use agricultural machinery for Class 2 and 1.4 tractors in adverse weather conditions or on heavy-textured soils.

The left-hand drop link is set to 740 mm and needs no readjustment, but in case of exigency.

The drop links are provided in addition to the main hole for coupling to the lower links with a slot to join up the wide-span machines and to follow the field relief more closely (cultivators, planters, and others).

The automatic hitch couplers CA-2 and CA-1 can be provided for the rear and front hitch linkages, respectively.

A single crossbar TCY-1 is provided to be installed at the rear hitch linkage axis. When the PTO shaft is to be used, a universal-joint shaft with the nominal length of 1000 mm may be recommended. In this case the mounting axis should be located at the middle of the universal-joint shaft; otherwise the PTO will be overload.

The tractor is equipped with three pairs of free hydraulic system outlets intended for connection to attached technical facilities (if no front coupler HY-2 is available).

The oil consumption through the outlets is 45...55 l/min. (depending on the technical condition of the hydraulic pump). The oil intake by the hydraulic cylinders should not exceed 25 l. The oil level in the hydraulic tank shall be carried out with the service cylinders rods fully drawn-in.

To avoid the oil losses when aggregating the technical means or in case of unexpected disconnection, the quick-hitch mechanisms, cut-off and break-off fittings

are provided (male half-couplings and break-away couplings), which are delivered optionally in the tractor's SPTA kit.

ATTENTION! The hydraulic system of the attached machine shall be coupled to the tractor hydraulic system by means of quick-hitch couplings. The coupling devices of semi-trailed machines should have adjustable support.

The hydrostatic power takeoff is possible through one of the outlets for driving the auxiliary hydraulic motors. To avoid overheating of the hydraulic system, the operating pressure shall not exceed 11 MPa that corresponds to the power of not more than 10 kW. To drain oil from the hydraulic motor bypassing the distributor, a separate pipeline is fitted.

The tractor incorporates the hydraulic valves and accessories with nominal cross-section $D_y = 12$ mm and coupling thread M20x1.5. If necessary, the suitable adaptors with nominal cross-section of at least $D_y = 12$ mm should be made by the user for connecting the machines with other fittings than those specified above.

The haul-and-draw coupler TCY-3B (lift type), page 181, and TCY-2P (типа "Python"), page 180 are used as intended. The TCY-2B coupling element is located at the distance of 111 mm away from the PTO end-face and will accept a substantial vertical load with sufficient longitudinal stability of the aggregate. The TCY-3B yoke is located at the distance of 320 mm away from the PTO end-face, thus, making it possible to attach the semi-trailed and pull-up machines with active drive and providing a larger angle between the tractor and the facility while the aggregate is turning. To achieve the required handling criterion, the vertical load on the TCY-3B yoke is reduced as compared to that on the TCY-2B yoke.

The structure of lift outfit guiding plates provides for installation of coupling members (a hook instead of a yoke, or other) made by other manufacturers.

For aggregating the PTO-driven machines, a coupling arrangement TCY-1M-01 (a drawbar) with changeable position of the coupling member with respect to the Cat. 3 and 2 PTO (500 and 400 mm, respectively) is provided.

If the tractor is fitted with the TCY-1M-01 (a drawbar), the TCY-2P ("Python") is not installed. When the TCY-1M-01 and TCY-2P are installed, the coupler TCY-3B (a yoke) can be left in its upper position. Also, in all these cases no dismantling of the rear hitch linkage is required.

The front-mounted hitch coupler Type HY-2 is similar to that of the rear one as to its design. It is mounted in place of the front counterweights and serves for making up the combined aggregates (a cultivator in front, seed planter in the rear, etc.), for mounting the echeloning implements (forward and side-mounted mowers, and others) as well as for transporting the certain machines from amongst rear-mounted combined aggregates in case of long trips.

PTO

Tractor: PTO tail-piece

Machine: PTU shaft

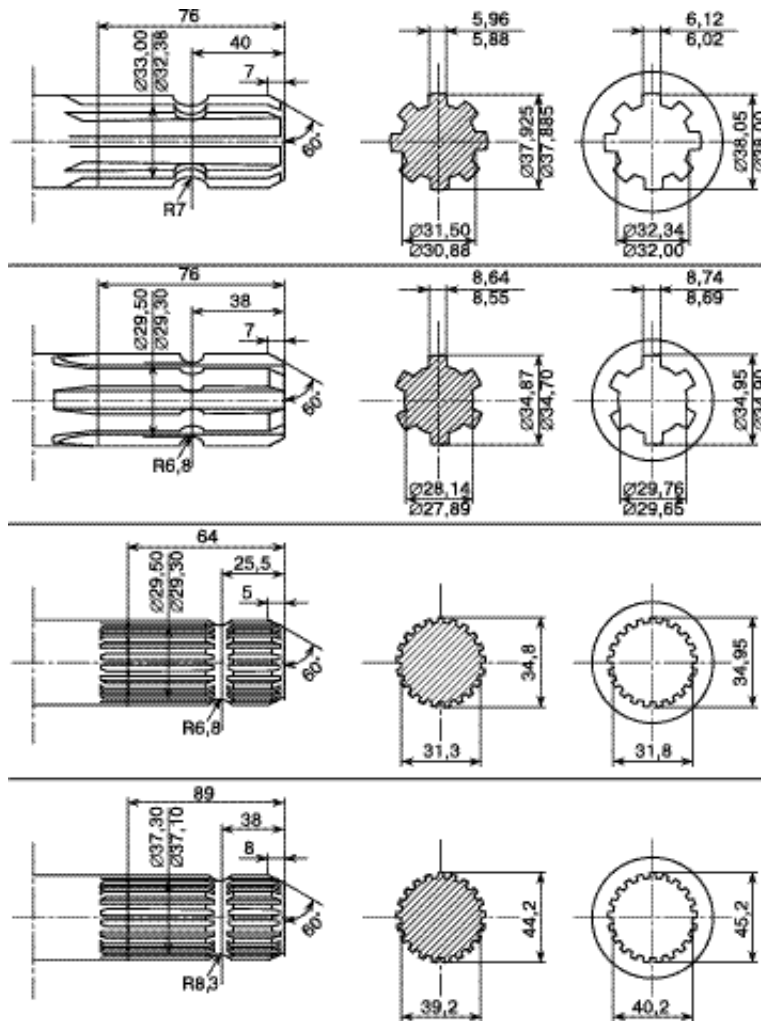

PTO	Tail-piece type	Rotational speed, rpm		Power transferred, kW (h.p.)
		PTO	Engine	
Rear, independent	PTO 1C	540	1924	60 (80)
	PTO 1	540	1924	60 (80)
	PTO 2C	1000	1909	60 (80)
	PTO 2	1000	1909	92 (125)
	PTO 3	1000	1909	125 (170)
Front, independent	PTO 2	1000	1845	50 (68)
Rear, synchronous	PTO 1C and 1 PTO 2 and 3	3,8 rev. per m of travel 6,2 rev. per m of travel		60 (80)

Using the PTO

The PTO shaft is intended for driving the active tools of the agricultural machines. The tractors are equipped with the front and rear power take-off shafts (PTO). The front PTO is used either with the front hitch coupler or its bracket (with no links of the hitch coupler installed). It is intended for driving the front-end machines/units (rotary cultivators, mowers, pumps, etc.). The front PTO is installed optionally. The rear PTO provides for both independent and synchronous drive of machines, while the front one – only independent drive.

The rear synchronous PTO is only used in those cases, when the MTA should perform a certain number of operations over a given path (for example, sowing) and drive active wheels of machines based on trailers and semi-trailers; in this case, the tail-piece used does not matter. The ground speed should not exceed 10 km/h.

ATTENTION!

- **It is obligatory for the universal-joint shaft drive of the agricultural machines to be attached to have safety elements (overrunning and safety clutches).** The choice of overrunning and safety clutches depends on the type of the agricultural machine to be used as well as on the MTA operation mode. When the rear PTO is employed at 540 rpm and the front PTO at 1000 rpm. it is necessary to install a safety clutch on the side of the power take-up shaft (PTU); the clutch restricts the power takeoff beyond the permissible limits (to no more than 60 and 50 kW, max., respectively). The safety clutch may be also installed for protecting from overload. To protect the PTO drive from overloading when combining the agricultural inertial-type machines with the tractor

(pick-up presses, forage-harvesting complexes and the like), a universal-joint shaft together with an overrunning clutch fitted on the PTU side, shall be used.

- The telescopic universal-joint shafts provide the transfer of torque. The type of universal-joint forks and length of the universal-joint shafts is determined in accordance with the distance from the hitch point to the PTO and the PTU and the method of coupling of machines to the tractor. With the location of the PTU with respect to the PTO on the machine to be attached which conforms to standards, employment of standard-make universal-joint shaft is possible.
- It should be kept in mind that, when the distances from the hitch point to the PTO and the PTU differ (i.e., vastly larger or lesser), the uneven rotation arises and the manoeuvrability of the tractor-machine combination suffers. Thus, it leads to reduced reliability and violation of agricultural regime of the MTA. In this case, it is necessary to use a universal-joint shaft with the constant speed joints (it should be part of the agricultural machine kit).
- The PTO shall be disengaged:
 1. After the MTA is stopped (provided the operation cycle of the agricultural machine to be attached is terminated);
 2. When the agricultural machine is raised to its transport position (valid for semi-mounted and mounted agricultural machines);
 3. When making sharp turns (valid for semi-mounted, semi-trailed and trailed agricultural machines).
- It is recommended to disengage the universal-joint shaft from the tractor when on a prolonged running session to other locations.

- NEVER engage the PTO:
 1. With the tools of the agricultural machine (rotary cultivators and the like) lowered onto, or put deep into, soil;
 2. If the material used in the technological process is on working tools of the agricultural machine or the tools are clogged;
 3. When the angle of inclination (of deflection) of the cardan driveline exceeds 20 degrees in whatever plane.
- When attaching the agricultural machine (with an active drive), be sure to proceed as follows:
 1. Check to see if the speed regime to be selected corresponds to the type of PTO and PTU tail-pieces installed;
 2. Make sure that the inner forks of joints of the intermediate (telescopic) shaft are in the same plane, since non-observance of this requirement results in overload of the cardan driveline and the PTO mechanism;
 3. On installing the universal-joint shaft, make certain that the telescopic elements of the driveline do not abut tractor components and, also, the telescopic parts overlap sufficiently (110...120 mm), since at less overlap the driveline can get open;
 4. Lock the lower links to exclude any possibility of transverse displacement when mounted or semi-mounted agricultural machines/implements are attached;
 5. If required, limit the lift height of mounted and semi-mounted agricultural machines/implements into the transport position, to exclude the possible contact and damage of the universal-joint drive as well as to ensure a sufficient gap between the tractor and the agricultural machine/implement.

**UNIVERSAL-JOINT SHAFTS WITH PROTECTIVE ENCLOSURE
(accessory of the machine to be attached)**

Universal-joint shaft of the type “10”

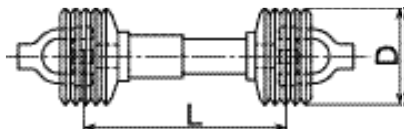

Telescopic, with universal joints and a protective enclosure.

Universal-joint shaft of the type “40”

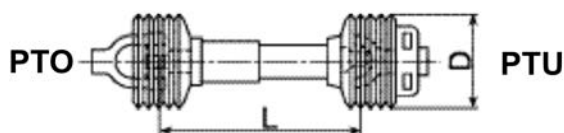

Telescopic, with a safety coupling and universal joints with a protective enclosure.

Universal-joint shaft of the type “20”

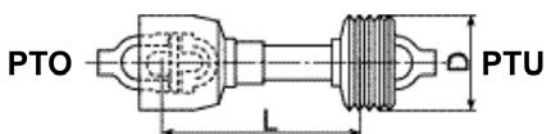

Telescopic, with a universal joint, a constant-velocity universal joint and a protective enclosure.

Universal-joint shaft of the type “50”

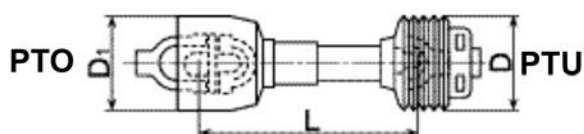

Telescopic, with a safety coupling and constant-velocity universal joint with a protective enclosure.

Universal-joint shaft designation *	Torque, N·m	Universal-joint shaft length, mm		Enclosure diameter, D, mm	Standard
		L	L ₁		
10.016	160	510	L ₁ = 1,35 L	150	State Standard (ГОСТ), ISO
10.040	400	560		175	
10.063	630	610 710		200	
10.1000	1000	610 710		220	

* Decimals after the point cover universal-joint shafts, type 20, 40, 50.
 L is the distance between the centres for a fully drawn-in universal-joint shaft (nominal length).
 L₁ is the operating length of the universal-joint shaft.
 D₁= 1.75 is the diameter of a constant-speed universal joint enclosure.

Installation of the Universal-Joint Shaft

Type of uni-versal-joint shaft	Hitch coupler	Tail-piece type	Universal-joint shaft nominal length, mm	Standard
"10" or "40"	HY-3	PTO 1C, 1, 3	610; 710	State Standard (ГОСТ)
	TCY-1Ж TCY-1 TCY-3B	PTO 1C, 1, 2	510	
		PTO 3	710	
"20" or "50"	TCY-2	PTO 1C, 1, 2, 3	710	

Installation of a universal-joint shaft with protective enclosure, together with the PTO hood, ensures safety of the joint.

ration and/or jamming of the connection.

The end yokes should be aligned in one plane

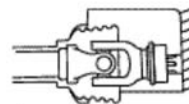

a)

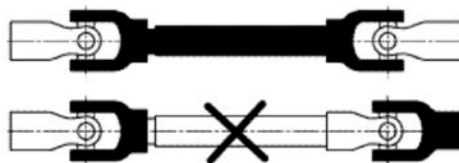

b)

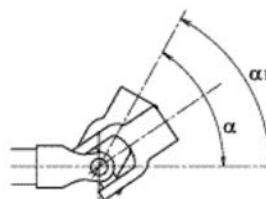

c)

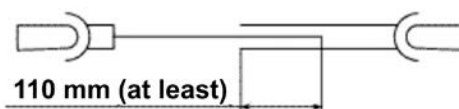

d)

PTO	Universal joints inclination angle (deg., not more than)	
	Univer-sal	constant-velocity cardan joint
Engaged	22	25 (50 for short period of time)
Disen-gaged	55	55

The overlapping of the shaft telescopic members shall be at least 110 mm to prevent sepa-

Choice of a Universal-Joint Shaft Type

Usually, the operating manuals for the machines to be aggregated specify the required power and rotational speed of the PTO. To choose the universal-joint type, the reference factor is the torque which can be determined from the nomographic chart below:

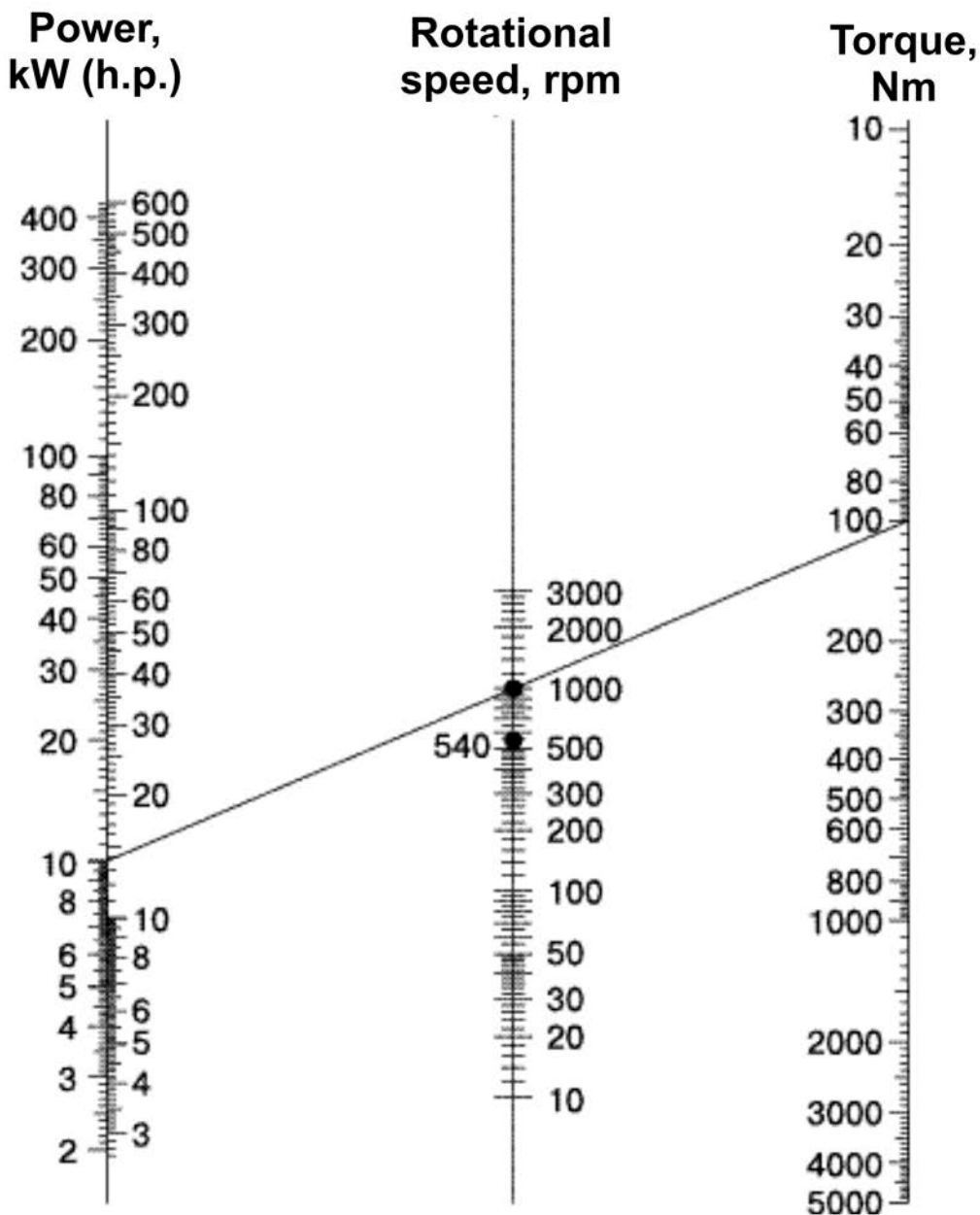

- 1000 rpm, 540 rpm – Standard rotational speed of the PTO.

PTO Drive without Universal-Joint Shaft

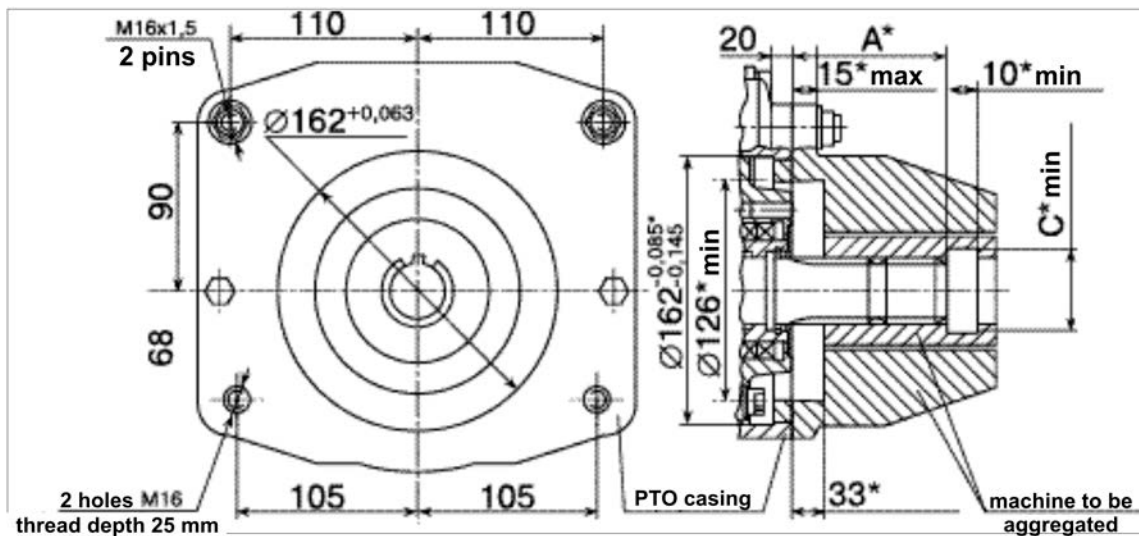

A number of units can be installed on the PTO directly, without a universal-joint shaft (reduction gear boxes, hydraulic pumps and others). In this case, it is necessary to provide alignment of housings to 162-mm diameter in the PTO cover. To avoid abutment against the tractor, grooves should be made on the side of the end-face and at the outlet of the PTO spline outlet. If required, the PTO cover fastening studs can be replaced with longer ones of the same thread diameter. Also, the lift hitch can be dismantled.

The procedure of attachment or installation of the units/implements on the front and rear PTO is the same.

Type of PTO tail-piece	A*	C* min
PTO 1; 1C; 2	90	Ø40
PTO 3	140	Ø50

* The dimensions attributed to the attached machines.

CONDITIONS OF SAFE AGGREGATING

To ensure the reliable and safe operation of the tractor, keep to recommendations for loading and stability specified in the Table below.

Parameters determining the condition of a safe aggregating of the tractor within the MTA		
Permissible loads on the axles		
Tractor axle		Loads range, kN
Front	$T_F=10 m_F$	12...45
Rear	$T_R=10 m_R$	20...70
Total maximum load on the tractor axles, kN		
$T=T_F+T_R$		≤90
The range of basic weight parameters of the tractor-based MTA, kg		
m_F	m_R	m_T
1200...4500	2000.. 7000	9000≥
<p>The tractor operating weight without machine, m_{WTr}, is determined by tractor’s outfit and limited by the factors, as follows:</p> <ul style="list-style-type: none"> • Permissible axle loads. • Total carrying capacity of tyres, used on the tractor. • Running speed. • Wheel tyre pressure. • Wheel track size. 		
Total axle load is subject to reduction in the following cases:		
In case of twinning the wheels		by 20 %
In case of augmentation of the wheel track by 7% per each 100 mm of its increase beyond 1800 mm		
$K_{steer}= m_F/m_{RT}$		≥0.2
Total operating weight of the towed vehicle, kg		≤15000
Total trailed operating weight, taking into account the critical longitudinal slope of 12 deg., kg		≥12000

where m_F is the front axle part of the total tractor operating weight in aggregate with a machine or without machine; m_R is the rear axle part of the total tractor operating weight in aggregate with a machine or without machine; m_T is the max-

imum allowable weight of the tractor supported by the front and rear wheels; T_F and T_R are allowable loads on the front and rear axles, respectively; T_T is the maximum permissible total load on the tractor axles and K_{steer} - is the steera-

bility criterion.

The actual values of the weights m_{RT} ; m_F ; m_R and m_T are to be determined by weighing on a weighbridge or by any other available method. To determine m_F and m_R , the tractor shall be placed on the platform of special balance with its front and rear wheels, in turn; while the wheels of the other axle shall be on hard surface level with the balance platform.

ATTENTION!

- **Load on the tractor front axle in an aggregate with an agricultural machine should be at least 20% (0.2) of the tractor own weight without attached machine.** Otherwise, the tractor will not demonstrate sufficient steerability and longitudinal stability. The indicator of the load adequacy is a C_{steer} factor (see Table 7-20) which is a ratio between the front-wheel part of the total tractor + machine weight and the operating weight of the tractor without the machine.
- If the front axle load is insufficient, increase the tractor operating weight in accordance with recommendations of this Manual as regards the tractor loading and ballasting. In all instances, the total amount of loads shall not exceed the total load-carrying capacity of the tractor tyres specified in table of loads on the tyres (see Table 7-21)). **If the load values obtained as the result of weighing, calculations and additional ballasting is greater than the permissible values, the aggregating of such machines/implements is forbidden.**

The Expedient loading and stability can be provided by following the recommendation given below:

- Following the recommendations of the Operating Manual for the Tractor.
- Using the recommended standard size of the tyres only.
- Inflating the tyres to the pressure values necessitated by the tractor axle

loads, jobs to be performed, and soil and weather conditions. The recommended tyre inflation pressures for the tractors with due account of actual loads can be found in Tyre Load-Capacity Table (Table 7-21). The tyre capacity decreases as the speed increases and the inflation pressure in tyres decreases.

- Maintaining the adequate speed when performing the field and transportation works.
- Combining the aggregating methods (working with the front and rear hitch linkages used at the same time) and ballasting.
- The total maximum weight of the tractor which falls on the front and rear wheels of the tractor should not exceed 9000 kg, with due observance of allowable axle loads.

RECOMMENDATIONS FOR IMPROVING THE GRIPPING-AND-TRACTION PROPERTIES OF THE TRACTOR AND SATISFYING THE STEERABILITY CRITERION

The tractor design provides for possible variation of the tractor operating weight and improvement of gripping and traction properties by way of tire ballasting and twinning of wheels as follows:

- Twinning of the front and rear wheels of the tractor.
- Filling the tyre tubes of tractor wheels with liquid.
- Using the standard (front) ballast and optional ballast (counterweights) to be installed on the rear or front hitch coupler.

Twinning the wheels makes it possible to reduce substantially the specific pressure on the ground and to preserve the soil structure, especially that of wetted fields. Twinning the wheels on dense soils makes it possible to improve the gripping and traction characteristics of the tractor, especially in conjunction with correct choice of the combination method: the values of the load and ballasting should not exceed the permissible values.

ATTENTION!

- For highly efficient employment of the tractor on jobs of different kinds, in a wide range of traction, it is necessary to follow recommendations on loading duties (see Table 7-20).
- Additional loading of the wheels by filling liquid (solution) into the tyre tubes of the tractor **should be only used in case of insufficient tyre grip with the soil under adverse conditions** (water-logged ground, etc.). If tyre gripping is satisfactory, filling the tyre tubes with liquid is not recommended, as it results in overload of the transmission and working equipment attached to the tractor.
- The tyres filled with liquid impair the smoothness of tractor running at speeds exceeding 20 km/h (transportation works).

ATTENTION! NEVER fill in the tyre tubes to their full volume, because it can result in the tyre carcass break in case of running over an obstacle on the road.

Allowable Loads on the Tractor Tyres Depending on the Pressure in the Tyres

Tyre	Load index	Speed symbol	Speed , km/h	Load per tyre, kg, at the internal pressure, kPa						
				60	80	100	120	140	160	180/200
420/70R24	130	A8	10	1700	1875	2050	2230	2405	2585	2850 (190кПа)/-
			20	1535	1720	1845	2030	2210	2335	
			30	1340	1500	1605	1765	1925	2035	
			40	1250	1400	1500	1650	1800	1900	
520/70R38	150	A8	10	2485	2940	3350	3725	4080	4410	4710/-
			20	2250	2660	3035	3370	3690	3990	4275/-
			30	2020	2390	2725	3030	3315	3585	3830/-
			40	-	-	2545	2830	3100	3350	3600/-
18.4R38	146	A8	10		2925	3240	3555	3870	4185	4710/5025
			20	2395	2655	2915	3170	3430	3690	4275/-
			30	2085	2310	2535	2760	2985	3210	3830/-
			40	1950	2160	2370	2580	2790	3000	3600/-

1. The pressure shall be set in the “cold” tyres.
2. When performing the works requiring large traction forces on the hook, set the pressure as for the speed of 30 km/h. When performing the transportation works on the roads with hard pavement, increase the pressure by 30 kPa.

SELECTING THE MACHINES TO BE AGGREGATED WITH THE TRACTOR

A great number of various technical facilities intended for agricultural tractors are now in service. These machines offer different technical characteristics which are defined by the type and conditions of jobs they are intended for.

The Operation and Service Manual provides for the information on the tractor design, capabilities of the working equipment designed to be aggregated with the tractor, load duties and regulations for safe operation of the tractor that makes it possible to select and aggregate the machines correctly. In any case, the recommendation given by the Manufacturer cannot be all-inclusive for all the cases of operation of the tractor, because even when the tractor is operated in pair with the same machine, its power parameters as well as impact of the machine and soil on the tractor are substantially different under various operating conditions.

The selection, outfit and employment of the tractor within a MTA based on specific machines are specified by the technical documentation for operation of the machines attached to each machine to be aggregated.

ATTENTION! Prior to aggregating or purchasing the specific machines, make sure that it is capable to operate in combination with a BELARUS tractor by proceeding as follows:

1. If possible, obtain the recommendations from the vendor (manufacturer) of the agricultural machine.
2. Make a thorough study of the Operation Manual for the tractor and machine.
3. Check the compliance as to:
 - power consumption;
 - load capacity of its mounting devices;
 - its mounting dimensions, including the conformance of the PTO and

the machine universal driveline coordinates;

- critical loads on the HDC, tyres, and tractor axles.
4. Make sure that all the working equipment required for aggregating the machines (PTO tail-piece of necessary standard size, front hitch coupler, reversible operating post, auxiliary spacer-ring piece for tyre twinning, hoses, break-away couplings, etc.) are available. Order or purchase it at extra cost, if required.
 5. Check the tractor's capability of moving within the MTA:
 - estimate the steerability;
 - possibility of running at the speeds required for fulfilling certain jobs;
 - off-road capability.
 6. Check the possibility of joint operation (in both transport and working position) of the tractor with the machine.

Tractors BELARUS of the models described can be used on almost entire range of farm jobs of general-purpose, in various soil and climatic zones, within a MTA combination based on machines with an average draft resistance of 25...30 kN. The tractors can be aggregated with the machines intended for operation with the tractors having the power exceeding 200 hp (such as BELARUS 2522, K 700 and other tractors of class 4...5) under favourable conditions (soils of normal moisture, with specific resistance of $r_s < 35 \text{ kN/m}^2$). On heavy soils and under adverse climatic conditions, the employment of machines designed for Class 1.4 and 2 tractors is conceivable. These tractors can be used for cultivation of row crops following special agronomic techniques which call for an expanded wheel track to ensure unobstructed run of the tractor.

The availability of the standard and additional equipment for aggregating makes it possible to use the tractors in agriculture in various combinations for power-consuming applications.

The working width and operating depth of an implement/machine depend basically on the specific resistance of soils which defines the operating speed range with due account of the agricultural requirements. The heavier is the soil, the higher is the unit resistance. Based on the average traction effort of 27...36 kN

developed by a Class 3 tractor on a stubble field, a rough estimate of the working width for the main power-consuming agricultural machine coupled to a tractor on average soils has been made. The results shown make it possible to choose agricultural machines/implements by their working widths including echelon arrangement obtained by means of coupling devices (harrows, cultivators, seeding machines, etc.). The figures given in Table 7-22 are approximate.

Technical means	Unit resistance P for medium soils, kN/m, at a speed of $v^* = 5$ km/h	Feasible working width, m
Share plough	12...14	2,0...2.5
Disk harrows	1.6...2.1	up to 12
Share scufflers	6.0...10.0	3...4
Cultivators	1.6...3.0	up to 10
Sowing machines	1.2...1.8	up to 12
Reaping machines	1.2...1.5	up to 15
Combine harvesters:		
silage harvesters	2.6...3.3	up to 3.0
beet combine	6...12	up to 3.0
potato harvester	10...12	up to 2.7
* A change in speed by 1 km/h results in the augmentation of unit resistance by up to 1%		

TILLAGE

Tillage is one of the most power-consumptive type of field operations. The BELARUS tractors of these models can be used on medium and large fields with 5...7-bottom share ploughs, depending on soil conditions.

The tractor is used as part of an aggregated tillage combination in line with a "tractor-furrow" pattern. It requires appropriate wheel arrangement when running with common, swivel and turnabout ploughs. Its aggregating with ploughs on "tractor wheel off the furrow" is also possible. In this case, the wheel arrangement pattern problem is less stringent. It is becomes therefore expedient to twin the rear wheel and improve the tractor gripping and traction properties, especially with tyres filled in with liquid.

To obtain smooth tillage, the swivel and two-way ploughs are used. They provide for high-quality tillage, without crown ridges and open furrows. To ensure the trouble-free and continuous operation of the tractor, it is recommended to use the ploughs equipped with automatic protection facilities: after such a facility comes into action and the plough passes over an obstacle, the plough body automatically reverts to its initial position, without interruption of the tillable aggregate operation.

When preparing for tillage, it is necessary to perform the following works:

- Checking and adjusting as necessary the rear hitch linkage.
- Rearrangement of the wheel in accordance with the tillage pattern selected.
- Checking and adjusting the plough in accordance with the directions of its operating manual.

To obtain the best results in ploughing, it is important to choose correctly the type and parameters of the plough. The plough type, cutting width (the number of plough bottoms) depend on the soil, its texture, the degree of contamination with stones and ploughing depth. Approximately, one plough bottom requires the power of 20 kW (on medium soils).

The speed regime of the tillage aggregate should be chosen taking into account the plough bottom type, soil group and climatic conditions, and so that the sufficient traction for overcoming the draft resistance of the plough and intermittent overloads would be achieved.

To maintain a technologically required speed and to obtain ploughing of good quality in case of aggravated soil and climatic conditions, it is a good practice to reduce the working width of the plough by removing the last bottom or in any other manner, if this operation is provided for by the plough design.

In case of ploughing of wet soils and on slopes following a "tractor wheels off the furrow" pattern, the slipping down into the open furrow is possible. In such cases it is preferable to plough using a "tractor-wheel-in-furrow" pattern, with reduced working width.

Approximate calculation of the plough operating width:

- Assess the type of the soil to be tilled.
- Find its specific resistance in Table 7-23.
- Calculate an approximate operating width for an ordinary shear plough by the formula given below.

$$B=30/(a \cdot P), \text{ где}$$

B – plough operating width, m;

a – ploughing depth, m;

P – unit ploughing resistance, kN/m².

Type of soil	Preceding cultural practices	Ploughing resistance for soils P, kN/m ² , at the tractor speed v * = 5 km/h,			
		Soil texture			
		heavy clay-loam	medium	light clay-loam	sandy loam, peat-boggy
Chernozem soil	Winter-crop stubble field	68	49	35	25
	Perennial grass sod	86	57	45	31
	Virgin soil, old sod field	90	71	52	39
Soddy-podzolic soil	Winter-crop stubble field	66	47	34	26
	Perennial grass sod	74	56	43	30
	Virgin soil, old sod field	92	71	50	40
Chestnut soil	Winter-crop stubble field	69	47	36	22
	Virgin soil, old sod field	98	58	55	29

* Change in speed by 1 km/h changes the ploughing resistance by up to 1%.

Diagram of Wheel Arrangement for Aggregating the Tractor with 5...7-Furrow Ploughs

The tractor wheels are in the furrow

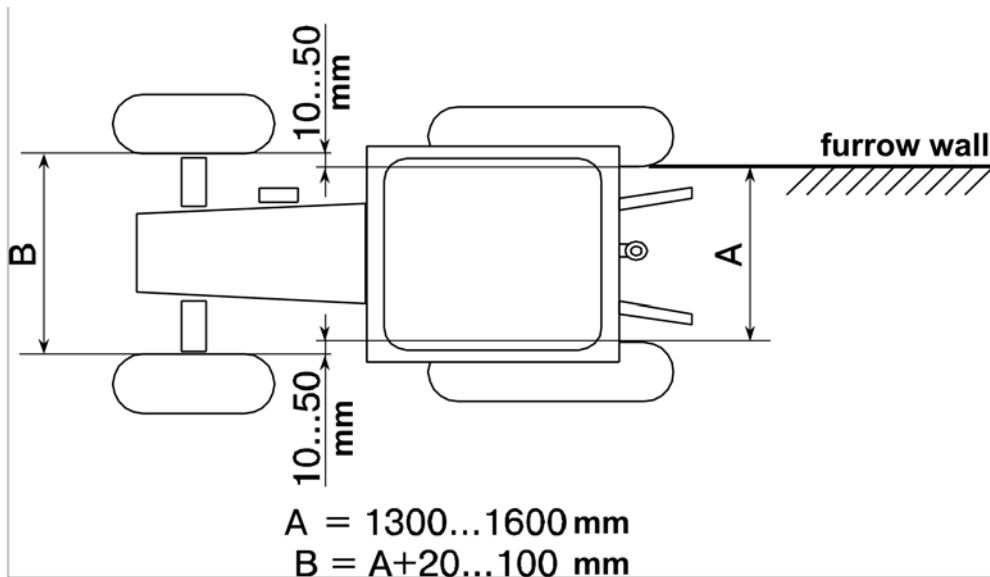

To obtain the wheel track figure, it is necessary to add the cross section of a respective tyre to the dimensions A and B.

The tractor wheels are out of the furrow.

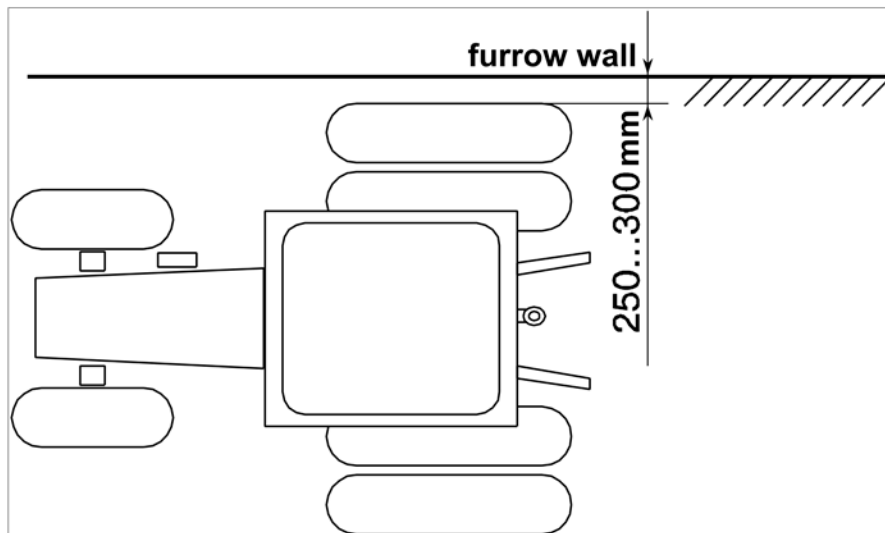

The rear wheel track is in accordance with the twinning pattern.

DRIVING THE TRACTOR ON PUBLIC ROADS

For as much as half of their operating time, tractors are used on public roads, including the hauling of agricultural machines in the transport position. All the vehicles intended for running on public roads shall meet more stringent safety requirements. In this case, the tractor and the machine/implement attached, trailed by or mounted thereon shall comply with the requirements for competent operation and maintenance. The tractor owner and/or operator are responsible for observance of the officially adopted traffic regulations and technical requirements imposed on road transport.

The vehicles whose width exceeds the tractor overall dimensions shall be equipped with cat's eyes.

Special permits and particular regulations are applied for driving the tractors whose overall dimensions with or without machine or implement including loaded or unloaded trailers and semi-trailers exceed at least one of the following dimensions on the public roads:

1. Height: 4 m from the road surface.
2. Width: 2.55 m.
3. Length: 20 m for tractors within a road train.
4. If the load projects beyond the vehicle clearance limits by 2 m or more.

Any departure from the above-listed normative figures is subject to agreement with the authorities responsible for road traffic.

IT IS PROHIBITED TO:

- Articulate the machines, transportation of loads with the weight and/or load distribution between the axles or tyres exceeding the values set forth in the Operating Manual for the tractor.
- Use trailed- and semitrailed-type agricultural machines including general-purpose trailers and semi-trailers, with no safety cables (chains) installed. One of unoccupied holes of the hitch linkage serves for attaching the safety chains (cables) (the mounting hardware shall be included in the scope of delivery of the machine to be aggregated).
- Use trailed and semi-trailed machines including trailers and semi-trailers of general- and special-purpose without service and parking brakes.
- Use a haul-and-draw coupling arrangement TCY-1 (crossbar) for transporting the technical facilities except in case of jobs to be performed in combination with agricultural machines in the field.
- Drive the tractor on roads of any type whatsoever including railroad crossings, if the machine(s)/implement(s) attached are not in transport position.
- Driving through railroad crossings of electrified sections without a special permit, if the outside dimensions exceeding the 4-m height limit.
- Driving the tractor backward (in reverse) on public roads, since the light-signalling equipment is only designed for the forward travel.
- Haul the attached agricultural machines with process cargo.

General-purpose vehicles should be attached through the TCY-2 or TCY-3 hitch couplers. The vehicles based on trailers and semi-trailers shall have a sign of maximum permissible speed limit at the rear or on the left side of the machine. The tractor wheel-track would rather be coordinated with that of the trailer (semi-trailer).

Aggregating the tractor in a road train (i.e. tractor + semi-trailer + trailer) is only permitted on dry hard-surface roads with the grades of up to 4%.

To connect signalling equipment of vehicles to be used in combination with the tractor, the tractor is provided with a 7-pin socket for supplying the instruments of the attached vehicle with electric power.

The service brake drive is a one-line circuit and is operated from the tractor operator's seat. The parking brake drive controls shall be fitted on the machine to be attached.

SELECTING THE TRACTOR SPEED

Job to be done	Tractor outfit	Speed, km/h, max.	Wheel track	Remarks
Operation on slopes		10	The wheel track shall correspond to the jobs to be done and correlate with the overall dimensions of the attached technical facilities: to be not less than the wheel track of the trailer (semi-trailer) attached. The wheel track recommended for transport missions – 1800 mm	Increase of the wheel track for improving the stability
Sharp MTA turns		10		On public roads
Running the MTA to operation site (excl. transport vehicles)		20		Without entering public roads
MTA moving (from field to field)	Tyres filled with solution. Twinned tyres	20		On public roads
Hauling missions	TCY-2B, TCY-3K, TCY-1M-01	30		

ATTENTION!

When selecting the tractor speed, the operator shall take into account the traffic density, features and conditions of the machines mounted or trailed and cargo to be transported; road and meteorological conditions as well as allow for tractor capacities, with due account of restrictions imposed by the traffic regulations and/or technological requirements of the job to be done. To ensure the road safety, the operator must take measures and be ready to speed down or stop in front of any obstacle.

The travel speed can be **limited by the features of the aggregated machine**, in conformity with the sign marked on the technical facility.

RUNNING THE TRACTOR IN REVERSE

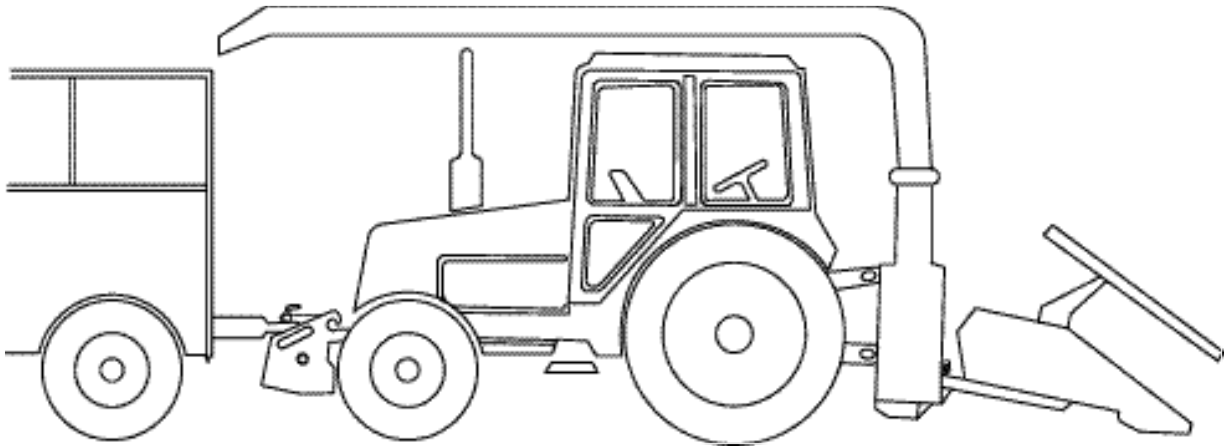

When performing a number of missions (forage harvesting, sugar beet harvesting, etc.) the MTA has to run on a stubble field. In this case, driving the tractor backwards for performing the required technological operations pays the additional expenses. Mounted or semi-mounted machines are usually employed for such jobs (reapers, combine harvesters and the like). A harvesting train may include a trailer for receiving the minced matter in bulk to be attached through a front hauling device, including the mounted counterweights or through a crossbar installed at the mounting axis of the HY-2 front hitch arrangement. The readjustment for reversible operation and conversely takes 3...4 minutes.

TROUBLESHOOTING

Trouble, symptoms	Remedy
ENGINE	
The engine fails to start:	
Air in the fuel supply system.	Bleed air from the system using the hand-operated lift pump. Eliminate the air inleakage into the fuel supply system (see Section "Description and Operation").
The fuel pump is faulty.	Remove the fuel pump from the engine and send it to the workshop for repair.
The fuel filters are clogged.	Wash the fuel coarse filter and replace filter elements of the fuel fine filter
The engine has too low temperature.	During the cold weather, preheat the engine using the available starting-facilitating means.
Engine fails to develop the full power:	
The fuel pump control lever would not rest at the stop.	Adjust the fuel pump control rods.
The fuel fine filter element is clogged.	Replace the fuel fine filter element.
The injectors are faulty.	Locate faulty injectors; wash and adjust them.
The injection advance angle is misadjusted.	Set the recommended fuel injection advance angle.
The supercharging pressure has decreased.	Remove the turbocharger from the engine and send the same to the workshop for repair.
Air inleakage into the fuel supply system.	Bleed air from the system using the hand-operated lift pump.
Engine smoky exhaust under all operation conditions	
Black smoke from the exhaust pipe:	
Engine air cleaner is clogged.	Service the air-cleaner.
Injector atomizer needle is stuck.	Locate a faulty injector, flush or replace the atomizer, adjust the injector.
Fuel pump is faulty.	Remove the fuel pump from the engine and send it to the workshop for repair.
Engine overloading	Reduce the engine loading by shifting-down.
The injection advance angle is misadjusted	Set the required fuel injection advance angle (see Section «Appendices»).
White smoke from the exhaust pipe:	
Engine is running overcooled.	Warm up the engine; during the work, maintain the coolant temperature within 70...95°C.
Ingress of water into fuel.	Change the fuel.
No valve-to-rock arm clearance.	Adjust the valve-to-rock arm clearances.
The injection advance angle is misadjusted.	Set the required fuel injection advance an-

Trouble, symptoms	Remedy
	gle.
Blue smoke from the exhaust pipe:	
Oil in the combustion chamber due to worn-out parts in the sleeve-piston assembly.	Replace worn-out parts of the sleeve-piston assembly.
Excess of oil in the engine crankcase.	Drain excessive oil and bring the oil level to top mark on the dip-stick.
The engine stops suddenly:	
The fuel is not fed.	Check the presence of the fuel in the fuel tank and working condition of the fuel pipelines, filters and lift pump.
The engine overheats:	
Lack of coolant in the cooling system.	Add the coolant up to normal level.
The radiator is dirty on the outside.	Clean the radiator.
Dirt and scale in the cooling system.	Clean the cooling system from impurities and/or scale and flush it.
The thermostat valve fails to open fully.	Replace the thermostat.
Insufficient tension of the fan belt:	
The tensioning device spring is broken;	Replace the spring. If it is impossible to replace the spring, it is admissible to interlock the fan clutch by clamping the alternator plate and the jockey pulley arm with nut and bolt.
Jamming of jockey-pulley on the lever axle.	Dismantle the tensioning device and remove the trouble.
The fan driving belt and pulleys are oily.	Remove the driving belt and clean the belt surface and pulleys from the traces of oil.
The oil pressure in a warmed-up engine is below the allowable value	
The pressure gauge indicator is faulty.	Replace the pressure gauge indicator after checking the oil pressure against a reference manometer.
Leaks in the connections of oil pipelines.	Locate the leak and restore the leak-tightness.
Oil pump is faulty.	Locate and remedy the fault.
Oil level in the engine crankcase is lower than the allowable one.	Top up oil to the upper mark on the dipstick.
The safety valve is jammed in the oil filter body.	Flush the valve through and adjust the pressure in the lubrication system.
Extreme wear-out of the crankshaft neck-to-bearing mating interface.	Send the engine to the workshop for repair.
Turbocharger	
Turbocharger rotor fails to rotate (a distinctive high-pitch tone is missing):	
Presence of foreign items, which impede the rotor rotation;	Remove inlet and outlet branch-pipes and remove the foreign items.
The rotor is seized in the bearing.	Replace the turbocharger.

Trouble, symptoms	Remedy
Higher ejection of oil from the side of the compressor or turbine, the leak-tightness of the turbocharger oil packing seals is disturbed.	Dismantle the turbocharger from the engine and send it to the workshop for repair.
Units of the automatic fan control system	
The cooling system fan fails to get ON at the water temperature at the engine outlet exceeding 97°C or fails to get OFF at the temperature of below 70°C:	
The thermopower transducer or the fan clutch is faulty.	Dismantle the fan clutch. Push the rod into the water pump as far as it will go and measure the length of its projecting part. Start the engine and warm it up until the water temperature at the outlet reaches 80-85°C. Then stop the engine and measure the rod part projecting from the water pump: 1. If the rod projection does not increase as compared with the initial position, replace the thermopower transducer; 2. If the rod projection end length has increased by 6...8 mm, replace the fan clutch and send the faulty clutch to the workshop for repair. If the replacement of the fan clutch is impossible, block the same by the above method.
Clutch	
The clutch fails to transmit the full torque (slips):	
Absence of clearance between the release shifter bearing and the release levers – “the clutch is disengaged incompletely” (insufficient free travel of the clutch pedal).	Adjust the clearance (see Section “Construction and Operation of Tractor Components”, item “Clutch Control Adjustment”).
Incomplete engagement of the clutch (the clutch lever (45) (see Section “Construction and Operation of Tractor Components”, figure in the item “Clutch drive”) fails to return to the initial position) on releasing the clutch pedal due to disturbance of the clutch control operation.	Locate and eliminate the cause.
The liners of the driven plates are worn out.	Remove the liners or driving plate assemblies.
Oiling of the liners of the driven plates due to ingress of oil into the dry compartment.	Locate and eliminate the cause of oil ingress into the dry compartment.
Insufficient force of the pressure springs (shrinkage of the springs in case of prolonged slipping and overheating of the clutch).	Replace the pressure plates.
The clutch is not disengaged completely (“drags”):	
The clearance between the release shifter bearing and the release levers is too large (large free travel of the clutch pedal).	Adjust the clearance (see Section “Construction and Operation of Tractor Components”, item “Clutch Control Adjustment”).

Trouble, symptoms	Remedy
Insufficiently full travel of the clutch lever (45) (see Section "Construction and Operation of Tractor Components", figure in item "Clutch drive") when the clutch pedal is stepped on completely.	Ensure that the free travel of the clutch lever and, respectively, hydraulic booster stroke when stepping completely on of the clutch pedal would be at least 24 mm
Maladjustment of the release levers.	Adjust the position of the release levers.
Increased warpage of the driven disks.	Check the end wobbling of the driven plate liners relatively to the outer diameter of the hub splines which shall be not more than 0.8 mm on the radius 165 mm. If the plates cannot be repaired, they shall be replaced.
Jamming of the driven plate boss on the transmission shaft splines.	Clean the splines to ensure the free travel of the plates on the transmission shaft.
The transmission shaft support bearing in the transmission is broken.	Replace the bearing.
The clutch lever (45) (see Section "Construction and Operation of Tractor Components", figure in item "Clutch drive") fails to return to the initial position on releasing the clutch pedal:	
Absence of clearance between the master cylinder piston and its lifter during the forward and reverse motion.	Perform the adjustment (see Section "Construction and Operation of Tractor Components", item "Clutch Control Adjustment").
Absence of clearance between the piston lifter of the master cylinder (30) (see Section "Construction and Operation of Tractor Components", figure in item "Clutch drive") and piston lifter of the hydraulic booster (39).	Perform the adjustment (see Section "Construction and Operation of Tractor Components", item "Clutch Control Adjustment").
Jamming of the master cylinder piston (which fails to return to the initial position) for the forward motion (10) (see Section "Construction and Operation of Tractor Components", figure in item «Clutch drive») and for the reverse (19) due to swelling of cups and O-rings that leads to blocking the compensation holes "A" (see Section "Construction and Operation of Tractor Components", item "Clutch drive", figure "Master cylinder")	Using the brake fluid of improper mark or presence of mineral oil, petrol, kerosene or diesel fuel in the brake fluid. Flush carefully the whole hydraulic drive system with brake fluid. Replace the damaged cups and O-rings in the master cylinders, service cylinder and tap. Change the brake fluid. Pump the brake fluid through the hydraulic system to bleed air in the forward and reverse motion.
Jamming of the master cylinder piston due to swelling of the collar.	
Jamming of the tap piston due to swelling of the O-ring.	
Impeded motion of the hydraulic booster piston.	Replace the hydraulic booster.
Lack of coaxiality of the hydraulic booster, master cylinder and lever (45) (see Section "Construction and Operation of Tractor Components", figure in item "Clutch drive").	Ensure the coaxiality of the hydraulic booster, master cylinder and lever (45) (see Section "Construction and Operation of Tractor Components", figure in item

Trouble, symptoms	Remedy
	"Clutch drive") by shifting the bolts of the bracket (40), hydraulic booster and bracket (33) before tightening.
Clogging the compensation hole in the master cylinder for the forward or reverse movement.	Clean the compensation hole of the master cylinder for the forward or reverse movement and bleed air from the system.
Loss of elasticity of the release spring (47) (see Section "Construction and Operation of Tractor Components", figure in item "Clutch drive").	Replace the spring (47).
The free travel of the clutch lever (45) is not provided (see Section "Construction and Operation of Tractor Components", figure in item "Clutch drive") when stepping on the clutch pedal	
Absence of clearance between the piston and the piston lifter of the master cylinder for the forward and reverse motion.	Perform the adjustment (see Section "Clutch Control Adjustment").
Absence of clearance between the piston lifter of the master cylinder (30) (see Section "Construction and Operation of Tractor Components", figure in item "Clutch drive") and piston lifter of the hydraulic booster (39).	Perform the adjustment (see Section "Clutch Control Adjustment").
Presence of air in the hydraulic clutch control system for the forward and reverse motion.	Pump the brake fluid through the hydraulic system to bleed air in the forward and reverse motion
Insufficient level of the fluid brake in the hydraulic system reservoirs for the forward and reverse motion.	Add the brake fluid to the normal level in the reservoirs of the master cylinders for the forward and reverse movement. Pump the brake fluid through the hydraulic system to bleed air in the forward and reverse motion.
Lack of the leak-tightness of the working chambers of the master and service cylinders and tap due to damage or wearing-out of the cups or O-rings.	Replace the cups or O-rings in the master and service cylinders and in the tap, if they are worn out. Check if the mirrors of the master and service cylinders and tap free of burrs, irregularities or cissing. Pump the brake fluid through the hydraulic system to bleed air in the forward and reverse motion.
Leakage of brake fluid in the connections or pipelines in the hydraulic drive system. Air inflow into the hydraulic system.	Tighten the connections, replace the damages parts. Pump the brake fluid through the hydraulic system to bleed air in the forward and reverse motion.
Clogging of the hole in the union of the reservoir (for the forward motion) or in the piston (for the reverse) causing the vacuum in the master cylinder due to which air is sucked through the seals into the cylinder.	Clean the hole. Pump the brake fluid through the hydraulic system to bleed air in the forward and reverse motion.
Blocking of the hydraulic drive pipeline due to a dent or clogging.	Replace the pipelines. Pump the brake fluid through the hydraulic system to bleed air in the forward and reverse motion.
Oil leakage through the O-rings of the hydraulic	Replace the O-rings in the hydraulic booster.

Trouble, symptoms	Remedy
lic booster.	
Insufficient free travel of the clutch pedal (the pedal rests against the cab wall).	<p>Increase the free travel of the clutch pedals for the forward and reverse motion by turning the forks (5, 15) (see Section "Construction and Operation of Tractor Components", figure in item "Clutch drive") and bolts (3, 17).</p> <p>Adjust the clearance between the piston and piston lifter of the master cylinder for the forward and reverse motion (see Section "Construction and Operation of Tractor Components", item "Clutch Control Adjustment"). Pump the brake fluid through the hydraulic system to bleed air in the forward and reverse motion.</p> <p>The travel of the piston lifter of the master cylinder (10) and (19) shall be at least 30 mm. The travel of the hydraulic booster piston and, respectively, of the clutch lever (45) when the clutch pedal is stepped on completely shall be at least 24 mm.</p>
No force on the clutch pedal.	<p>Presence of air in the hydraulic system. The cups and O-rings in the master and service cylinders and tap are worn-out.</p> <p>Replace the cups and O-rings in the master and service cylinders and tap. Check if the mirrors of the master and service cylinders and tap free of burrs, irregularities or cissing. Pump the brake fluid through the hydraulic system to bleed air in the forward and reverse motion.</p>
The hydraulic booster, service cylinder and рычаг (45) (see Section "Construction and Operation of Tractor Components", figure in item "Clutch drive") are not set coaxially.	Ensure the coaxiality of the hydraulic booster, service cylinder and lever (45) by shifting the bolts of the bracket (40), hydraulic booster and bracket (33) before tightening.
The flexible hose (24) (see Section "Construction and Operation of Tractor Components", figure in item "Clutch drive") dilates, swells, lengthens.	Replace the flexible hose (24).
Gearbox	
Low pressure in the hydraulic system:	
Lack of oil in the transmission housing.	Add oil to the "П" (Full) mark ± 5 mm against the oil gauge glass.
Clogging of the hydraulic system screen.	Wash the screen.
Seizure of the overflow valve in the distributing filter.	Flush the distributing filter valve.
High pressure in the hydraulic system:	
Seizure of the overflow valve in the distributing filter.	Flush the distributing filter valve.
The oil draining channels in the transmis-	Flush the oil draining channels.

Trouble, symptoms	Remedy
sion are blocked.	
No pressure in the hydraulic system:	
The drive of the hydraulic system pump is OFF.	Turn the pump ON.
Lack of oil in the transmission housing.	Add oil to the "П" (Full) mark.
Excessive noise when shifting gears:	
The clutch fails to disengage fully (the clutch "drags").	Adjust the clutch.
The cone surfaces of the synchronizers and gear surfaces are worn-out.	Replace the worn-out parts.
Excessive noise:	
Lack of oil in the transmission housing.	Add oil to the "П" (Full) mark.
Bearings and/or other parts of the transmission are worn-out or broken.	Replace the bearings and/or other parts as necessary.
Rear axle	
Excessive noise in the main drive:	
The main drive gear meshing is misadjusted in both spot pattern and lateral clearance.	Adjust the main drive meshing in accordance with the spot pattern. Adjust the lateral clearance in the main pair meshing (0.25...0.55 mm).
Tapered bearings of the main drive are misadjusted.	Adjust the bearing preload.
Low oil level in the transmission housing.	Check the oil level in the transmission housing; add the oil, if necessary.
The gear teeth are damaged.	Check the condition of the rear rings. No presence of chips or damages (pitting) is allowed. The gears with the damaged teeth shall be replaced as a pair.
The differential lockup does not function:	
The lockup clutch plate friction surfaces are worn out.	Change the plates.
The lockup clutch diaphragm is damaged.	Change the diaphragm.
Low pressure of oil fed into the lockup actuator.	Check the oil pressure applied to the lockup clutch. It shall be 9-10 kgf/cm ² at the oil viscosity within 18...26 mm ² /s).
Lockup control electrohydraulic valve is inoperative.	Check safety fuses, relays and other circuit components for operability and the slide valve for easy and smooth travel; eliminate the fault.
Low pressure in the hydraulic system of the transmission	
Lack of oil in the transmission housing.	Add oil to the "П" (Full) mark.
Clogging of the hydraulic system screen.	Wash the screen.
Seizure of the overflow valve in the distributing filter.	Flush the distributing filter valve.
High pressure in the hydraulic system of the transmission	

Trouble, symptoms	Remedy
Seizure of the overflow valve in the distributing filter.	Flush the distributing filter valve.
No pressure in the hydraulic system of the transmission	
The drive of the hydraulic system pump is OFF.	Turn the pump ON.
Lack of oil in the transmission housing.	Add oil to the "П" (Full) mark.
Excessive noise when shifting gears	
The clutch fails to disengage fully (the clutch "drags").	Adjust the clutch.
The cone surfaces of the synchronizers and gear surfaces are worn-out.	Replace the worn-out parts.
Excessive noise:	
Lack of oil in the transmission housing.	Add oil to the "П" (Full) mark.
Bearings and/or other parts of the transmission are worn-out or broken.	Replace the bearings and/or other parts as necessary.
Brakes	
Inefficient braking:	
Increased pedal travel.	Perform the adjustment as describes in Section "Construction and Operation of Tractor Components", item "Adjusting the Brakes".
Air inleakage into the hydraulic actuator system due to drop in brake fluid level in the master cylinder reservoirs below the mark "Min".	Add the brake fluid to the "Max" mark. Bleed air from the hydraulic actuator system.
Loss of leak-tightness of the master and service cylinders due to damage of the collars.	Replace the collars. Bleed air from the system.
Leakage of brake fluid through the joints of pipelines and hoses at the places of damage.	Tighten the captive nuts and clamps, replace the damaged parts. Add the fluid to the required level. If necessary, bleed the system.
The brake disks are worn out.	Replace the disks.
Incomplete release of all the brakes:	
No free travel of the pedal	Perform the adjustment (see Section "Construction and Operation of Tractor Components", item "Adjusting the Brakes").
Jamming the collars of the master and service cylinders из-за:	
<ul style="list-style-type: none"> • soiling and corrosion of working surfaces; 	Replace the protective boots. Clean and wash the cylinders, remove the corrosion. Replace the collars.
<ul style="list-style-type: none"> • swelling of the sealing collars due to ingress of mineral oil. 	Flush the system through. Replace the collars.
Incomplete return of the pedals to their initial position after braking:	
<ul style="list-style-type: none"> • Breakage of the release springs of the 	Replace the springs

Trouble, symptoms	Remedy
pedals, service cylinders and pressure disks.	
Incomplete release of one of the service brakes:	
Loosening or breakage of the release springs of the pressure disks.	Replace the springs
Jamming of the master cylinder piston due to:	
<ul style="list-style-type: none"> • soiling or corrosion; 	Disassemble the working cylinder, clean the parts from dirt and corrosion and bleed air from the system.
<ul style="list-style-type: none"> • swelling of the sealing collars due to ingress of mineral oil. 	Replace the collar, flush the system and bleed air from there.
Non-uniform braking of the right- and left-hand wheels:	
War-out of the friction surfaces of one of the disks.	Replace the disks.
Maladjustment of the length of the link bolts of the service brakes.	Perform the adjustment (see Section "Construction and Operation of Tractor Components", item "Adjusting the Brakes").
Poor operation of the leveling valves of the hydraulic actuator.	Remove the tube connecting the two master brake cylinders; remove the unions and leveling valves from the master brake cylinders; check the quality of the collars and the presence of the balls. Replace the worn-out parts.
Clogging or crushing of the pipelines of brake control or leveling valves of the master brake cylinders.	Clean or replace the pipelines.
Spontaneous locking of the brake levers on axles.	Remove the brake levers from the axle, clean mounting seats on the axle for the levers, lubricate them with grease and refit them on the axle.
ATTENTION! The failure of the tractor brakes is often caused by using the trailed and semi-trailed brakeless machines blocked with the tractor brakes. Never use the trailed and semi-trailed brakeless machines blocked with the tractor brakes, if their mass exceed half of the tractor mass.	
PTO	
Rear PTO fails to transmit full torque or continues to rotate on applying the brake:	
Maladjustment of the control.	Adjust the distributor control.
Low oil pressure in the transmission hydraulic system.	Adjust the pressure-relief valve on the transmission hydraulic system.
Low oil pressure at the outlet to the PTO friction clutch and brake due to excessive leak in the PTO friction clutch and brake.	Check the pressure applied to the PTO friction clutch and brake. If necessary, replace the O-rings of the PTO friction clutch and reduction gear brake or distributor.
Low oil pressure at the outlet to the PTO friction clutch and brake due to jamming of the distributor sliding valve.	Dismantle the distributor, clean and wash its parts; eliminate the cause of jamming. Replace the damaged parts, if any.
The operation of the friction clutch or brake	Wash all the friction clutch and brake parts

Trouble, symptoms	Remedy
is disturbed due to hanging-up of the pistons or wearing-out of the friction disks.	in clean diesel fuel; change the friction disks, if necessary.
Front driving axle	
Insufficient traction of the front driving axle	
The drive clutch fails to transmit the torque:	
Lack of pressure in the clutch booster.	Dismantle the distributor and wash its parts.
Slipping of the drive clutch.	Check and adjust the pressure in the hydraulic system of the transmission (11...12 kgf/cm ²). Replace the worn-put plates.
Electrical circuit of the FDA control system is faulty.	Locate and eliminate the fault.
Insufficient value of the torque transmitted by the clutch due to oil leakage in the hydraulic system:	
Wear-out of the rubber sealing rings.	Replace the rings.
Wear-out of the piston rings and clutch drum.	Replace the rings.
Wear-out of the mating surfaces between the casing and the drum hub" and between the drum and the piston.	Replace the worn-out parts.
Drive fails to operate in the automatic mode:	
Maladjustment or failure of the switch of the automatic engagement sensor.	Adjust the position of the switch or replace the latter.
Excessive noise and heating in the main drive zone:	
Excessive play in the main drive gear bearings.	Adjust the gear bearings.
Incorrect mesh of the main drive gears.	Check and, if necessary, adjust the mesh against the contact spot.
Noise at the maximum angle of turning of the angle:	
Incorrect operation mode of the FDA. The FDA operates all the way in the forced engagement mode.	Check the mode of engagement of the FDA drive and set the switch to the OFF or AUTO position.
Incorrect limit angle of turn of the wheels.	Check and adjust the angle.
Knocking in the pivot during the motion:	
Maladjustment of the pivot bearings.	Check and adjust the bearings.
Knocking in the FDA in case of sudden turning of the wheels:	
Excessive play in the pins of the steering link and hydraulic cylinders of turning.	Check and adjust the pins.
Oil leakage through the collar of the main drive flange:	
Wear-out or damage of the flange collar.	Replace the worn-out parts.
Oil leakage through the breathers of the wheel reduction gears:	
Too high oil level.	Check the level and adjust the same as required.
Oil leakage through the collar of the driving gear of the wheel reduction gear	
Excessive clearance in the gear bearings.	Check and adjust the bearings.
Wear-out or damage of the collar.	Replace the collar
Angular oscillations of the wheels:	
Axial clearance in the bearings of the wheel reduction gear pivots.	Check and adjust.

Trouble, symptoms	Remedy
Excessive clearance in the bearings of the front wheels.	Check and adjust the clearance in the flange bearings.
Excessive clearance in the bearings of the HPS hydraulic cylinders.	Replace the worn-out parts.
Excessive wear and ply separation of front tyres:	
Toe-in is misadjusted or disturbed.	Adjust the toe-in as described in Section "Adjustments".
Tyre inflation pressure does not correspond to that recommended.	Keep the pressure in the tyres according to the recommendations (see Section "Aggregating the Tractor with Agricultural Machines and Implements").
The FDA is all the way operated in the forced engagement mode.	Check the FDA engagement and disengagement. If any faults will be detected, eliminate them.
Steering control	
Excessive force to be applied for turning the steering wheel:	
1. No or insufficient oil pressure in the hydraulic system of the steering wheel due to:	1. The oil pressure in the hydraulic system of the steering wheel shall be 140...155 bar (at the stop): Bleed air from the hydraulic system.
<ul style="list-style-type: none"> ● the relief valve of the metering pump has hung up in the open position or adjusted to low pressure. 	*● Wash the relieve valve and adjust it to the pressure of 140...145 bar.
<ul style="list-style-type: none"> ● the feeding pump is faulty or designed for counter-clockwise rotation. 	● repair or replace the pump.
2. Excessive friction or jamming in the mechanical components of the steering column.	2. Eliminate the friction in the steering column: <ul style="list-style-type: none"> ● reduce the tightening of the upper nut; ● lubricate the rubbing surfaces of the plastic bushings; ● eliminate the contact of the universal joint with the walls of the steering column bracket.
3. Excessive torque of turning of the FDA reduction gears.	3. Repair the FDA.
The steering wheel rotates without turning the steerable wheels:	
1. No oil in the tank.	1. Fill in the tank with oil up to the required level and bleed air from the hydraulic system.
2. The relief valve is set to the pressure exceeding the set point of the anti-hammer valves.	*2. Adjust the setting of the relief and anti-hammer valves.
3. When disassembling and reassembling the non-return valve, the ball was not refitted.	*3. Refit the ball of the non-return valve.
The seals of the hydraulic cylinder piston	4. Repair or replace the hydraulic cylinder.

Trouble, symptoms	Remedy
are worn-out.	
When rotating the steering wheel, the steerable wheels turn in opposite direction:	
The high-pressure hoses are connected to the steering hydraulic cylinder or metering pump incorrectly.	Refit the high-pressure hoses.
The steering is too slow or too difficult when rotating the steering wheel rapidly:	
1. The feeding pump is faulty.	1. Repair or replace the pump.
2. The feeding pump of too low capacity is installed.	2. Install the feeding pump of the standard size specified in the Operating Manual.
3. The relief valve of the metering pump is set to low pressure or has hung up in the open position due to dirt.	**3. Wash the relieve valve and adjust it to the pressure of 140...145 bar.
The steering wheel fails to return to the neutral position, tendency to “motoring” of the metering pump:	
1. Excessive friction or jamming in the mechanical components of the steering column.	1. Eliminate the friction in the steering column. To do this: <ul style="list-style-type: none"> ● loosen the tightening of the upper nut; ● lubricate the rubbing surfaces of the plastic bushings; ● eliminate the contact of the universal joint with the walls of the steering column bracket.
2. The splined tail-end of the steering column and the metering pump shaft are not aligned coaxially (due to excessive thrust of the universal-joint shaft).	2. Release the universal joint; to do this, cut the end face of the upper fork of the universal or reduce the height of the lower rubber bushing to get the clearance between the end face of the upper fork of the universal joint and the cage.
3. The clearance between between the splined tail-end of the steering column and slide valve of the metering pump is absent or too small.	3. Shorten the splined tail-end, if its end projects over the mating face of the steering column bracket by more than 7.1 mm, or set additional washers with the thickness of not more than 1.5 mm between the metering pump and the bracket.
“Motoring” of the metering pump (the steering wheel continues to rotate after the turn):	
1. Seizure of the sleeve with the slide valve, possibly, due to dirt.	*1. Wash the parts of the metering pump and re-assembly them in accordance with the manufacturer’s instructions.
2. The return springs of the slide valve have lost the elasticity or been broken.	*2. Replace the springs
The continual correction of the steering wheel is required (the steering wheel does not hold the road):	
1. The return springs of the slide valve have lost the elasticity or are broken.	*1. Replace the springs
2. The spring of the anti-hammer valves is	*2. Replace the spring and adjust the pres-

Trouble, symptoms	Remedy
broken.	sure of the anti-hammer valves.
3. The gerotor pair is worn out.	*3. Replace the gerotor pair.
4. The cylinder piston seals are worn-out.	*4. Replace the defective parts of the cylinders.
Strong blows on the steering wheel in both directions:	
Incorrect setting of the universal joint in the metering pump.	*Re-assemble the metering pump in accordance with the manufacturer's instructions.
Excessive play of the steering wheel:	
1. The tapered fingers of the hydraulic cylinder or steering tie-rods are not tightened.	1. Tighten the nuts of the fingers with the torque of 180...200 Nm and fix them with cotter pins.
2. The splines of the steering column tail piece are worn out.	2. Replace the lower fork of the universal joint.
3. The universal-joint shaft of the steering column is worn out.	3. Replace the universal-joint shaft.
4. The return springs of the slide valve have lost the elasticity or are broken.	*4. Replace the springs
Oscillation of the steerable wheels (wobbling) during the motion:	
1. Excessive play of the fingers of the universal joints of the steering tie-rods and hydraulic cylinder.	1. Tighten the nuts of the fingers and universal joints of the steering tie-rods.
2. Wear-out of the mechanical connections or bearings.	2. Replace the worn-out parts.
3. Presence of air in the hydraulic system.	3. Bleed air from the hydraulic system.
Oil leaks over the tail-piece of the slide valve of the metering pump, cover or body of the gerotor pair:	
1. Wear-off of the slide valve seal.	*1. Replace the slide valve seal by means of a special fixture.
2. The bolts of the metering pump cover are loosened.	2. Tighten the bolts with the torque of 3...3.5 kgf·m.
3. The gaskets under the heads of the bolts of the metering pump cover are damaged.	3. Replace the gaskets.
Different minimum radii of turn of the tractor to the left and to the right:	
The toe-in of the wheels is not adjusted.	Adjust the wheel toe-in.
Incomplete angle of turn of the steerable wheels:	
1. Insufficient pressure in the hydraulic system of the steering control:	*1. Adjust the pressure in the hydraulic system:
● the relief valve is set to low pressure.	*● set the valve to the pressure of 140...145 бар;
● the feeding pump is faulty	● repair or replace the pump.
2. Increased torque of turning of the FDA reduction gear.	2. Repair the FDA.
Failure of the feeding pump:	

Trouble, symptoms	Remedy
High pressure in the hydraulic system of the steering control.	
<ul style="list-style-type: none"> • incorrect connection of the high-pressure hoses. 	<ul style="list-style-type: none"> • the hoses shall be connected in strict compliance with the operating manual.
<ul style="list-style-type: none"> • jamming of the relief valve of the metering pump. 	<ul style="list-style-type: none"> * • wash the relief valve and adjust it to the pressure of 140...145 bar.
Oil leakage over the slide of the reverse tap:	
The rubber O-rings are damaged or worn-out.	Replace the rings (to prevent the rings from being cut off against sharp edges of the holes in the casing when being replaced, the slide of the tap shall be moved out of the casing in turn to the both sides by not more than 7 mm)
<p>* ATTENTION! Taking into account the extreme complexity and responsibility of the metering pump from the standpoint of the steering control safety, its disassembling and re-assembling shall be only performed by a specialist of the customer service department of the manufacturer (or other authorized service organization) having been trained appropriately, got familiar with the construction of the metering pump and documentation for servicing, disassembling and reassembling of the metering pump as well as subject to availability of all the required special fixtures, tools and special hydraulic stand ensuring the adjustment and checking of the parameters and operation of the metering pump after the repair performed. Otherwise, the full responsibility for inoperability of the metering pump shall be imposed on the person who performed the disassembling and reassembling of the metering pump, replacement of the parts or setting of the valves as well as on the tractor owner.</p>	
Hydraulic Lift Linkage	
<p>The lift linkage without load fails to move upwards; when any of the distributor handles is set to the “lift” or “drop” position, no distinctive sound emitted by the pump under load is heard:</p>	
Clogging of the relief valve of the tractor’s distributor.	Dismantle and wash the relief valve. Adjust the pressure maintained by the relief valve.
<p>The lift linkage without load fails to move upwards; when any of the distributor handles is set to the “lift” or “drop” position, a distinctive sound emitted by the pump under load is heard. On stopping the engine and moving the position handle to the foremost and then rearmost position and starting the engine, the lift linkage moves upwards (the draft handle shall be in the foremost position):</p>	
Clogging of the nozzle hole in the discharge valve.	Dismantle the regulator-distributor from the tractor, remove the bypass valve from it, wash the valve and clean the valve nozzle hole.
<p>The lift linkage without load fails to move upwards; when any of the distributor handles is set to the “lift” or “drop” position, a distinctive sound emitted by the pump under load is heard. On stopping the engine and moving the position handle to the foremost and then rearmost position and starting the engine, the lift linkage does not move upwards (the draft handle shall be in the foremost position):</p>	
Penetration of foreign particles under the	Remove the cover from the regulator-

Trouble, symptoms	Remedy
slide edges.	distributor and set the position handle to the foremost position. The retaining ring of the slide shall rest against the regulator-distributor body. Move the position handle to the rearmost position. The slide shall move upwards by at least 7 mm. If the displacement will be less, dismantle the regulator-distributor and remove the foreign particles seized between the edges of the slide and body.
The lift linkage with load fails to move upwards or its movement is slowed down:	
The fault appears as oil in the hydraulic system is warmed up: the pump is faulty.	Check the pump capacity. Should the pump efficiency be below 0.7, replace the pump.
The fault appears at any oil temperature: the discharge valve is clogged.	Dismantle the regulator-distributor, remove the bypass valve from it and wash the valve and the body in diesel fuel.
The lift linkage with load moves upwards slowly; after stopping the engine, its spontaneous lowering is visually noticeable; the position corrections are frequent, the pressure can be suspended:	
Destruction of the rubber seals of the regulator-distributor.	Remove the regulator-distributor and replace the rubber seals by the new ones.
The pump is not unloaded over the whole range of travel of the lift linkage with load when using the position method of adjustment on reaching the specified position be the lift linkage:	
In case of insignificant movements of the position handle towards the drop position, the pump is unloaded for short time; after stopping the engine, the leak-tightness is normal	
Jamming of the accelerator valve or loss of its leak-tightness.	Dismantle the regulator-distributor; remove, disassemble and wash the bypass valve. If necessary, fit the valve ball to its seat.
When moving the position handle towards the drop position, the pump is not unloaded; after stopping the engine, the leak-tightness is normal:	
Loss of leak-tightness of the pressure-setting valve.	Screw out the tapered plug on the top surface of the regulator, remove the spring, fit the valve ball to its seat and refit the parts.
The lift linkage with load moves spontaneously downwards to a small distance on reaching the position set by means of the position handle ("sagging" of the lift linkage):	
Loss of leak-tightness of the anti-sagging valve.	Remove the regulator-distributor, screw out the plug of the anti-sagging valve, remove the spring, fit the ball to its seat and refit the parts.
The position of the position handle at the digits "1" and "9" does not correspond to the transport and bottom positions of the lift linkage, respectively:	
Maladjustment of the position rope in the drive.	Align the respective positions of the handle and lift linkage by rotating the nuts fastening the shell of the cable to the bracket in the

Trouble, symptoms	Remedy
	panel and to the bracket on the hydraulic lift.
The lift linkage without load fails to move upwards or moves in jerks, on engaging the distributor, the pump “squeals”:	
Insufficient quantity of oil in the hydraulic system.	Make sure that the oil tank contains oil, if necessary, replenish oil.
Spontaneous movement of the draft or position handle on the panel:	
The pressure of the friction washers on the bracket in the panel is loosened.	Adjust the spring pressure by means of the nut on the bracket axle until the defect is eliminated.
Electric equipment	
Low degree of charging of the storage battery:	
The intermediate resistance between the terminals of the storage battery and wire lugs is increased due to loosening and oxidation.	Dress the connecting terminals, tighten the contact parts and lubricate them with technical petroleum jelly. Tighten the fastening of the battery disconnect switch and bridge.
The alternator is faulty (no voltage at the “+” and “Д” terminals).	Remove the alternator and send it to the workshop for repair.
The storage battery if faulty.	Replace the storage battery.
Slipping of the driving belt.	Adjust the tension of the alternator drive belt (see Section “Scheduled Maintenance”).
The storage battery “boils” and requires frequent addition of distilled aqua:	
The storage battery if faulty.	Replace the storage battery.
When the starter is switched on, the engine crankshaft does not rotate or rotates very slowly:	
The storage battery terminals are loosely tightened or wire lugs are oxidized	Dress the lugs and tighten up the terminal clamps.
The storage battery has been exhausted below the allowable limit.	Charge or replace the storage battery.
The commutator and brushes have got fouled.	Dress the commutator and the brushes.
Poor contact between the brushes and the commutator.	Remove the starter from the engine, dress the commutator, eliminate the wedging of the brushes in their box-guides or replace them, if worn-out.
Maladjustment of the solenoid starter switch.	Adjust the switch.
The engine start interlock device has operated or its switch is faulty.	Set the GB levers to the neutral position and check the operability of the switch. If necessary, adjust the switch position by means of adjusting shims.
The engine is not prepared for starting at the temperature of below + 5°C.	Prepare the engine for starting at low temperatures.
After starting the engine the starter remains in the ON state:	
The starter power disk is tacked to the starter relay contact bolts.	Stop the engine, disconnect the storage battery and dress the contacts of the solenoid starter switch.
The drive pinion does not get out of mesh with the flywheel rim due to breakdown of	Replace the return spring of the release lever.

Trouble, symptoms	Remedy
the release lever spring.	
The solenoid valve of the engine start assisting facilities does not operate:	
Poor contact in the electromagnet coil circuit.	Check the circuit and tighten the wire fastening contacts.
Alternator noise:	
Slipping or excessive tension of the alternator drive belt.	Remove the alternator and send it to the workshop for repair. Adjust the tension of the alternator drive belt.
Electric tachospeedometer	
For the tachospeedometer troubleshooting see Section "Drive Controls and Instrumentation".	
System of heating and air cooling in the cab	
No warm air is fed to the cab	
No water circulation through the heating unit:	
The tap on the cylinder block head is closed.	Open the tap.
Ice plugs in the heater hoses.	Break ice and pass hot water through the hoses.
The heater fan does not operate.	Remove the fan fault and check the electric circuit for switching on the fan.
High humidity of the air passed to the cab:	
Water leakage in the heater radiator.	Eliminate the leakage or replace the radiator.
Water leakage in the connections of the heater system.	Tighten the buckles.
Pneumatic system	
Pressure in the receiver builds up slowly:	
Air leakage from the pneumatic system:	
<ul style="list-style-type: none"> • The nuts of the pipelines, fittings and binding screw clamps are loosened or damaged. 	Detect the places of leakages and eliminate them by tightening the connections or replacement of the damaged parts.
<ul style="list-style-type: none"> • The rubber seal of the connecting head is damaged. 	Replace the damaged seal.
<ul style="list-style-type: none"> • The nut of the O-ring of the connecting head has been loosened. 	Tighten the nut.
<ul style="list-style-type: none"> • Penetration of dirt under the connecting head valve. 	Clean the valve.
<ul style="list-style-type: none"> • Contact of the dirt-protection cover with the stem of the connecting head valve. 	Eliminate the contact.
<ul style="list-style-type: none"> • Maladjustment of the valve actuator. 	Perform the adjustment (see Section "Construction and Operation of Tractor Components", item "Checking and Adjusting the Brake Valve of the Pneumatic System and Its Actuator").
<ul style="list-style-type: none"> • The operation of the pressure regulator and brake valve is disturbed. 	Remove the pressure regulator and brake valve and send them to the workshop for repair.
The pressure in the air bottle rises slowly:	

Trouble, symptoms	Remedy
Air leakage through the compressor valves.	Remove the compressor head and clean the valves and their seats from coke deposits. Replace the damaged parts.
Sticking or run-out of compressor piston rings	Remove the head and cylinder of the compressor, clean the rings from coke deposits and replace them as necessary.
Pressure in the air bottle drops quickly when the engine is stopped:	
Air leakage through coupling elements of the pneumatic system.	Eliminate the leakage.
On stepping on the brake pedals, the air pressure in the bottle drops quickly:	
The inlet valve is warped, clogged or damaged.	Eliminate the warpage, clean or replace the valve.
The brake valve diaphragm is damaged.	Change the diaphragm.
Insufficient air pressure in the bottle:	
Air leakage.	Eliminate the air leakage.
The pressure regulator operation is disturbed.	Remove the pressure regulator and send it to the workshop for repair.
The suction or pressure valve of the compressor is faulty.	Clean the compressor valves from coke deposits or replace them, if they are excessively worn-out.
Excessive wear of the piston rings, jamming of the compressor rings.	Clean the compressor rings from coke deposits or replace them.
Excessive ejection of oil to the pneumatic system by the compressor:	
Jamming or wear-out of the compressor piston rings.	Clean the compressor rings from coke deposits or replace them.
The pressure regulator switches the compressor on to idling at the pressure of less than 0.77...0.80 MPa (7.7...8.0 kgf/cm²) and into action – at less than 0.65 MPa (6.5 kgf/cm²) or at more than 0.70 MPa (7.0 kgf/cm²):	
Clogging of the chambers, pockets and channels of the pressure regulator.	Clean and wash the pressure regulator.
The adjusting cap is uncottered.	Adjust the pressure of switching the compressor ON/OFF.
Loss of elasticity, damage or rupture of rubber parts; irreparable slackening of springs.	Change the damaged parts.
Warpage or hanging-up of the pressure regulator operating members.	Check the valves for sliding ability; lubricate, if necessary.
The pressure regulator is frequently operates (turns the compressor ON) without taking air from the air bottle:	
Air leakage from the pneumatic system or pressure regulator, damage of the back-pressure valve of the regulator.	Remove the back-pressure valve and send it to the workshop for repair.
The pressure regulator functions as a relief valve:	
The adjusting cover is screw down too much.	Remove the adjusting cover and send it to the workshop for repair.
Seizure of the discharge piston in the dia-	Remove the diaphragm assembly and send it to the workshop for repair.

Trouble, symptoms	Remedy
phragm assembly.	
Absence of clearance between the discharge piston and the bottom cover; the outlet holes in the cover are clogged.	Screw off the cover, clean the outlet holes and check the clearance.
No air is supplied to the coupling hose through the air-intake valve:	
The stem of the air-intake valve in the pressure regulator is sunk insufficiently.	Screw the nut of the coupling hose fully down onto union.
The pressure regulator has switched the compressor to idling.	Reduce the pressure in the receiver to below 0.65 MPa (6.5 kgf/cm ²).
Displacement of the rubber ring on the air-intake valve.	Screw out the cover and check the position of the O-ring and its condition..
The trailer's brakes are ineffective:	
The brake valve fails to maintain the pressure in the control mainline at the level of 0.77...0.80 MPa (7.7...8.0 kgf/cm ²).	Adjust the brake valve and its actuator (see Section "Construction and Operation of Tractor Components", item "Checking and Adjusting the Brake Valve of the Pneumatic System and Its Actuator").
The brake valve fails to drop the pressure in the coupling mainline to zero.	Adjust the brake valve and its actuator (see Section "Construction and Operation of Tractor Components", item "Checking and Adjusting the Brake Valve of the Pneumatic System and Its Actuator").
The pressure in the coupling mainline drops to zero too slowly.	Check the condition of the mainline, atmospheric opening in the valve and the pedal travel.
The operation of the trailer's brake system is disturbed.	Perform the adjustment.
The trailer's brakes are released too slowly:	
Maladjustment of the brake valve and its actuator.	Perform the adjustment (see Section "Construction and Operation of Tractor Components", item "Checking and Adjusting the Brake Valve of the Pneumatic System and Its Actuator").
The operation of the trailer's brake system is disturbed.	Perform the adjustment (see Section "Construction and Operation of Tractor Components", item "Checking and Adjusting the Brake Valve of the Pneumatic System and Its Actuator").
Air-conditioner	
The electromagnetic clutch of the compressor fails to operate (when turning the temperature regulator, no distinctive metallic click is heard):	
Electric equipment failure.	Check the operability of the block of pressure sensors by means of a tester or multimeter; the leads of the block of sensors (red and pink wires) shall be rung out between one another. Check the intactness of the connections of the electric circuits from the compressor coupling to the air conditioner control panel.

Trouble, symptoms	Remedy
The coolant leakage took place.	Detect the coolant leakage place. The detection of the leakage places and replacement of the hoses and components of the air conditioner shall be performed by trained personnel using the special equipment.
The air conditioner fan motor fails to operate.	Electric equipment fault: Check the intactness of the respective fuse (25 A, see electric diagram) on the fuse block located in the dashboard. Replace the blown out fuses by new ones. Check the presence of supply voltage at the air conditioner motor M7 by means of a test lamp when the switch is set to the ON position and the battery is connected. If the electric circuits are intact, but no supply voltage is present at the motor M7, replace the switch.
When the air conditioner is switched on in the cooling mode, warm air is delivered to the cab.	Destruction of the sealing element of the tap П0-11 (or BC11). Replace the tap П0-11 (or BC11).
Coolant leakage from the ventilation compartment of the cab.	Burst of the heater tubes ("defrosting" of the heater due to incomplete drainage when operating in the cold season with water). Replace the climatic unit of the air conditioner.
Electronic control systems of the DL, FDA, GB reduction gear, front PTO and RHL	
The FDA drive or rear axle differential lockup cannot be not engaged in the forced mode, the reduction gear cannot be switched to a higher stage, the front PTO drive cannot be engaged:	
No supply voltage is applied to the respective electromagnet of the electrohydraulic distributor.	Check the application of the supply voltage to the respective electromagnet against the electric connection diagram (see diagrams in Section "Appendices")
Jamming of the slide of the respective electrohydraulic distributor.	Wash the electrohydraulic distributor
No pressure in the hydraulic system of the transmission.	Eliminate the fault in the hydraulic system.
When the front PTO drive is engaged (the pilot lamp is ON), the tail piece fails to rotate:	
Make sure that the cylinder rod moves when being engaged.	If the cylinder rod moves, the electric control of the front PTO is operable.
Check the adjustment of tightening of the brake band of the front PTO.	If necessary, perform the adjustment
The rear axle differential lockup or FDA drive cannot be engaged in the automatic mode in the straightforward position of the steerable wheels:	
Excessive clearance between the bracket and, respectively, end face of the left- and	Adjust the clearance within 3 ± 0.2 mm by turning the nuts (6) and (7) as shown in Fig-

Trouble, symptoms	Remedy
right-hand ЭВИТ-С3 sensors of turn angle of the steerable wheels.	ure "Adjusting the ЭВИТ-С3 Sensors of the Angle of Turn of the Steerable Wheels" in Section "Construction and Operation of Tractor Components".
Breakage in the "minus" circuit of the power supply or in the "signal" circuit of the left- (34) or right-hand (35), respectively, turn angle sensors (see "Electric Connection Diagram of the Control Systems of the LD, FDA and GB Reduction Gear" in Section "Appendices").	Check the electric circuits against the electric connection diagram.
The right- or left-hand turn angle sensor, respectively, is faulty.	Replace the faulty sensor.
When braking the tractor (stepping on the both pedals at the same time) the FDA drive cannot be engaged or the rear axle DL cannot be disengaged (on stepping on any brake pedal):	
One or both BK 12-21 sensors of application of the brakes (operation of the brake pedals) (see "Electric Connection Diagram of the Tractor" in Section "Appendices").	Simulate in turn the operation of the sensors by closing the contacts in the terminal blocks of the bundle to the sensors.
The bundle is faulty	Check the bundle for intactness against the electric connection diagram (see "Electric Connection Diagram of the Control Systems of the LD, FDA and GB Reduction Gear" in Section "Appendices").
The relays (10, 11, 12 and 13) (see «Electric Connection Diagram of the Control Systems of the LD, FDA and GB Reduction Gear» in Section «Appendices») in the circuit of engagement of the FDA drive and engagement of the rear axle DL during the brake are faulty.	Replace the relays.
The lamp of engagement of the lower reduction gear stage fails to light up on starting the engine, or the lamp of engagement of the higher reduction gear stage fails to light up after switching the reduction gear to a higher reduction gear stage:	
The oil pressure in the hydraulic control system is below 0.8 MPa.	Check the oil pressure against the transmission oil pressure gauge in the dashboard. Eliminate the fault in the hydraulic system or adjust the relief valve.
The ДСДМ-М pressure sensor of the higher or lower stage of the GB reduction gear (37) or (38), respectively, is faulty or the pilot lamp of engagement of the GB reduction gear (6) or (24) is blown out, or the LED of the GB reduction gear (40) or (39) is blown out (see "Electric Connection Diagram of the Control Systems of the LD, FDA and GB Reduction Gear" in Section "Appendices").	Replace the faulty components (pressure sensor or pilot lamp, or LED).
Open circuit from the sensor to the pilot lamp or from the sensor to the LED.	Check the integrity of the "sensor – pilot lamp" or "sensor – LED" circuit and elimi-

Trouble, symptoms	Remedy
	nate the breakage in the faulty circuit (see “Electric Connection Diagram of the Control Systems of the LD, FDA and GB Reduction Gear” in Section “Appendices”).

List of possible defects in the RHL control system 3HY and methods of their diagnostics

Defect code	Description and possible cause of the defect	Method of diagnostics and remedy
Magor defects		
11	Fault in the control circuit of the lifting solenoid valve. Open-circuit in the solenoid winding or the electromagnet or in the electromagnet control bundle.	Disconnect the cable assembly from the electromagnet and check the latter for open-circuit using a tester. The electromagnet resistance shall be not more than 2...4 Ω. If the electromagnet is in good order, check the electromagnet control bundle for mechanical damage and the wire for open-circuit from the terminal of the electromagnet plug-in socket to terminal (2) of the 25-pin connector on the electronic unit using a tester (see the electric connecting diagrams of the RHL control systems in Section "Appendices").
12	Fault in the control circuit of the dropping solenoid valve. Open-circuit in the solenoid winding or the electromagnet or in the electromagnet control bundle.	Disconnect the cable assembly from the electromagnet and check the latter for open-circuit using a tester. The electromagnet resistance shall be not more than 2...4 Ohms. If the electromagnet is in good order, check the electromagnet control bundle for mechanical damage and the wire for open-circuit from the terminal of the electromagnet plug-in socket to terminal (14) of the 25-pin connector on the electronic unit using a tester (see the electric connecting diagrams of the RHL control systems in Section "Appendices").
13	Fault in the control circuit of the dropping or lifting solenoid valve. Short-circuit in one of the electromagnets or of the electromagnet control wires in the bundle	Disconnect the bundles from the electromagnet and check the electromagnets for short-circuiting using a tester. The electromagnet resistance shall not exceed 1.6 Ohms. Or, alternatively, measure the electromagnet current consumption with the voltage of 6 V applied thereto. The current shall not exceed 3.2 A. With the connector assembly disconnected, check terminals (2) and (14) for short-circuit (when doing so, the electromagnets shall be disconnected), (see the electric connecting diagrams of the RHL control systems in Section "Appendices").
14	Fault in the control circuit of the dropping and lifting solenoid valves. Open-circuit in one of wires in the electromagnet control bundles.	Check the common bundle of the system for mechanical damage. Disconnect the connector assembly from the electronic unit, disconnect the connector assemblies from the electromagnets, and check the wire for open-circuiting from terminal (6) of the electronic unit connector assembly to the terminal on the electromagnet connector assembly. Check the presence of the supply voltage at terminal (5) of the electronic unit connector assembly (see the electric connecting diagrams of the RHL control systems in Section "Appendices") (to do

Defect code	Description and possible cause of the defect	Method of diagnostics and remedy
		this, it is necessary to start the engine). If no voltage is present at the terminal, check the reliability of connection of the wire to the safety fuse and intactness of the safety fuse. The safety fuse is located in the safety fuse box. The safety fuse is energized after the engine is started.
15	Fault of external control buttons. Short-circuit of wires or locking of one of the external control buttons; at the same time, the hitch leverage starts to lift or drops immediately after the engine is started.	Check the bundles from the external control buttons for mechanical damage. Switch off the buttons one by one until the defect disappears. When switching off the buttons, the engine shall be stopped. Should the defect not disappear when the buttons are OFF, it would be necessary to disconnect the connector assembly from the electronic unit and test terminals (10) and (12), (20) and (12) for short-circuiting using a tester (see the electric connecting diagrams of the RHL control systems in Section "Appendices").
16	Fault in the electronic unit. The stabilized supply voltage used to energize the control panel is below the level required. Short-circuit in the RHL draft and position sensor connector assembly due to ingress of water onto the terminal contacts.	Disconnect the common bundle from the main control panel. Measure the stabilized supply voltage at pins (6) (minus) and (4) (plus) of the main control panel (see the electric connecting diagrams of the RHL control systems in Section "Appendices"), which shall be 9.5-10 V (the engine shall be running). If the supply voltage is too low or absent, it is necessary to check the reliability of connection of the electronic unit connector assembly. Disconnect the RHL draft/position sensors one by one.
22	Fault in the position sensor. The sensor wire is broken or the sensor is not connected.	Check to see that: <ul style="list-style-type: none"> • the electric connector assembly is reliably plugged in to the position sensor; • the bundle connected to the sensor is free of mechanical damages; • the RHL eccentric is properly located, i.e. at the maximum drop of the RHL the sensor shall be squeezed to its "min" position, and vice versa; • the position sensor is properly adjusted (if the fault becomes apparent with the RHL in its bottom position, the sensor should be screwed in, and if in its top position, the sensor should be screwed out).

Defect code	Description and possible cause of the defect	Method of diagnostics and remedy
Medium defects		
23	The main control panel is faulty. The ploughing depth potentiometer is faulty.	Check the connector assemblies of the control panel and electronic unit for reliable connection as well as check the bundle for mechanical damage. Check output voltage against the electric diagram (see the electric connecting diagrams of the RHL control systems in Section "Appendices").
24	The main control panel is faulty. The RHL top position potentiometer is faulty.	Check the connector assemblies of the control panel and electronic unit for reliable connection as well as check the bundle for mechanical damage. Check output voltage against the electric diagram (see the electric connecting diagrams of the RHL control systems in Section "Appendices").
28	The main control panel is faulty. The RHL control lever is faulty.	Check the connector assemblies of the control panel and electronic unit for reliable connection as well as check the bundle for mechanical damage. Check output voltage against the electric diagram (see the electric connecting diagrams of the RHL control systems in Section "Appendices").
31	The right-hand draft control transducer is faulty. Open-circuit in the cable or short-circuiting in the sensor.	Check the connection of the cable to the draft control transducer and the cable itself for mechanical damage. Also, the overload of the draft control transducer is possible.
32	The left-hand draft control transducer is faulty. Open-circuit in the cable or short-circuiting in the sensor.	Check the connection of the cable to the draft control transducer and the cable itself for mechanical damage. Also, the overload of the draft control transducer is possible.
Minor defects		
34	The main control panel is faulty. The RHL rate control potentiometer is faulty.	Check the reliability of connection of the connector assemblies of the control panel and electronic unit as well as the bundle for mechanical damage. Check output voltage against the electric diagram (see the electric connecting diagrams of the RHL control systems in Section "Appendices").
36	The main control panel is faulty. The combined ploughing control (draft/position) potenti-	Check the reliability of connection of the connector assemblies of the control panel and electronic unit as well as the bundle for mechanical damage. Check output voltage against the electric diagram (see the electric connecting diagrams of the RHL control sys-

Defect code	Description and possible cause of the defect	Method of diagnostics and remedy
	ometer is faulty.	tems in Section “Appendices”).

TRACTOR TRANSPORTATION AND TOWING

The tractors can be transported by railway, on motor vehicles and/or trailers. Also, the tractors may be delivered to the place of destination by towing and under its own power.

Prior to transporting the tractors:

- Set the GB levers to the first gear;
- Apply the parking brake;
- Fasten the tractor to the platform using the wire bracing with the diameter of 3-5 mm, chains or guy ropes.

When handling the tractor for loading/unloading, use the facilities with lifting

capacity of at least 10 tf. Hoist the ropes at the front axle beam and the rear wheel half-axes as shown in the diagram below.

A tractor with a non-operating HPS pump may be towed over the distance of up to 5 km, at a speed of up to 10 km/h.

To connect a towing rope, an eye fastened to front-end counterweights and to their bracket is provided.

When towing the tractor, observe strictly the traffic regulations.

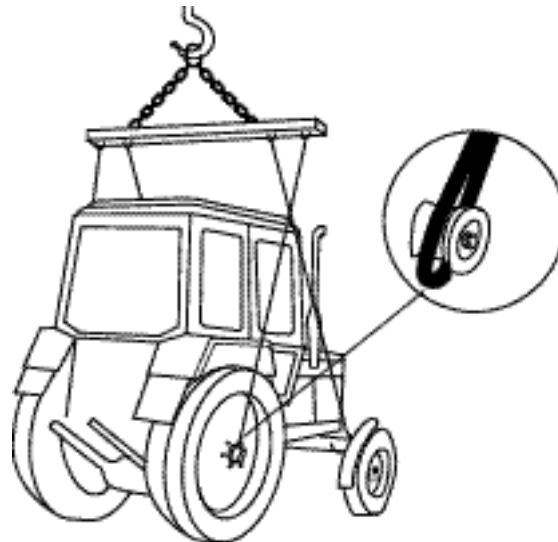

Tractor slinging diagram

SCHEDULED MAINTENANCE

The operator shall perform the daily inspection of the tractor for preventing the loosening of the joints, holders and fasteners, leaks of the coolant and oil, for removing the dirtying of the tractor’s mechanisms as well as carry out the scheduled maintenance for ensuring the tractor operability, fire safety and **safety in fulfilling various missions as a part of the machine-tractor aggregate.**

Directions for Operation and Servicing of the Hydraulic Systems of RHL and HPS:

- When servicing the hydraulic systems of the rear hitch linkage and the steering controls of the tractor, it is a must to strictly observe the change intervals of filter elements and oil. DO NOT use oils (for filling refilling) which are not recommended in the tractor Operation and Service Manual.
- Prior to filling or changing of filter elements, be sure to clean the filler plugs, necks, filter caps and the surfaces adjoining thereto from dust and dirt. When changing the filter elements, wash the inner surfaces of filter housings and caps in diesel-fuel.
- When coupling the tractor with hydraulically-operated agricultural machines, thoroughly clean couplings, unions, adaptors and other connecting hardware on the agricultural machine and on the tractor.

•When the rear hitch linkage is operated under high loads (as well as when running with hydraulically-operated agricultural machines) and is filled with oil of unknown origin, it is a good practice to change the filter elements more frequently.

Keep it always in mind that clean oil in the hydraulic system guarantees its trouble-free operation.

Capacities of Filling Tanks, Bottles and Reservoirs, l

Engine crankcase/ Lubrication system		18/22
Engine cooling system		31
Transmission		47
Fuel pump*		0.25
FDA wheel reduction gear box (each)		2.0
FDA main drive		5.0 (5.5)*
Hydraulic system oil reser- voir		35
HPS oil reservoir		12
Fuel tanks (2 off)		270
Hydraulic actua- tor of the clutch and service brakes	1523/ 1523.3	0.4
	1523B/ 1523B.3	0.8

* For the FDA with a cast-in-block beam.

** In case of installation of a new or over-hauled fuel pump.

SCHEDULED MAINTENANCE CHART*

Oper. No.	Operation description	Intervals, hours					
		10	125	250	500	1000	2000
1	Checking the oil level in the engine	X					
2	Checking the coolant level in the engine	X					
3	Checking the oil level in the transmission	X					
4	Checking the oil level in the HPS oil tank	X					
5	Checking the oil level in the RHL oil tank	X					
6	Checking the brake liquid level in the master cylinder tanks of the hydraulic actuator of the clutch and the brakes	X					
6a	Checking the brake liquid level in the compensation chamber of the master cylinder for controlling the clutch and brakes in the reverse	X					
7	Drain condensate from the pneumatic system bottle	X					
8	Checking brake for proper operation, operability of the engine, steering controls, lighting and signalling devices in the motion	X					
8a*	Checking the fastening of the air-conditioner hoses	X					
8b*	Checking/cleaning the air-conditioner condenser	X					
8c*	Checking the draining tubes of the air conditioner/cleaning them from condensate	X					
8d	Removing condensate from the reservoirs of the radiator of the charge air cooler (CAC) of the engine (BELARUS-1523.3/1523B.3)	X in winter	X in winter				
8e	Cleaning the radiator of the charge air cooler (CAC) of the engine (BELARUS-1523.3/1523B.3)	X					
9*	Checking/adjusting the tension of the air-conditioner compressor driving belt		X				
9a	Greasing the pivot points of the HPS cylinders		X				
10	Greasing the bearings of the axle of the FDA pivots		X				
11	Draining the sediment and sludge from the fuel tanks and the fuel course filter		X				
12	Checking the tension of the alternator driving belt		X				
13	Checking the tyre inflation pressure		X				
13a	Checking the tightening of fasteners of the hubs and wheels		X				
14	Checking and adjusting the clutch control mechanism		X				
15	Checking the engine air cleaner		X				
15a	Clean the filter of the cab ventilation and heating system		X				
15b	Checking the tightening of the bolts of the CAC Air Ducts		X				
16	Greasing the clutch release yoke bearing			X			
17	Cleaning the rotors of the centrifugal oil filters of the engine and the gear-box			X			
18				X			
19	Washing the screen filter in the gear-box hydraulic			X			

* If the air conditioner is installed.

Oper. No.	Operation description	Intervals, hours					
		10	125	250	500	1000	2000
	system						
20	Changing oil in the engine crankcase			X			
21	Changing the replaceable filter element on the engine oil filter			X			
23	Checking the oil level in the front PTO reduction gear box (if installed)			X			
24	Checking the front wheels for toe-in			X			
25	Checking the oil level in the final drive and hub reduction gear housings			X			
26	Checking the turbocharger for tightening of fasteners			X			
27	Checking and adjusting the clearances in the engine valves				X		
28	Draining sediment and sludge from the fuel fine filter				X		
29	Checking the steering wheel for play				X		
30	Checking the FDA flange bearings for clearances				X		
31	Adjusting the travel of the brake pedals and parking-reserve brake lever				X		
32	Servicing the storage batteries				X		
33	Changing the replaceable filter element in the oil tank of the RHL hydraulic system				X		
34	Changing the replaceable filter element in the oil tank of the HPS hydraulic system				X		
35	Checking the alternator fastening bolts for proper tightening				X		
36	Check the plays in the steering link joints				X		
37	Checking the joints of the air cleaner and the engine intake duct for leak-tightness				X		
38	Checking the pneumatic system for leak-tightness				X		
39	Checking the bolts of clamps of the CAC air ducts for tightening (BELARUS-1523.3/1523B.3)				X		
40	Changing the oil in the RHL hydraulic system oil tank				X		
41	Checking the clearances in bearings of the hub reduction gear driving pinion and the FDA pivot axles				X		
41a	Replacement of the drying filter	After every 800 hours of operation or once a year					
42	Checking the cylinder head fastening bolts for proper tightening					X	
42a	Changing the brake fluid in the clutch and brake actuator					X	
43	Checking the external bolted joints for proper tightening					X	
44	Cleaning the fuel coarse filter					X	
45	Washing the engine turbocharger					X	
46	Changing oil in the transmission housing					X	
47	Changing oil in the HPS oil reservoir					X	
48	Replacement of the filter element in the fuel fine filter					X	

Oper. No.	Operation description	Intervals, hours					
		10	125	250	500	1000	2000
49	Checking the alternator					X	
50	Changing oil in the FDA hub reduction gear and the final drive					X	
51	Changing oil in the front PTO reduction gear-box (if installed)					X	
52	Checking the condition of the brakes					X	
53	Greasing the bushings of the rear (front) hitch linkage turn shaft and of the hauling mechanism					X	
54	Servicing the air-cleaner					X	
56	Checking the fuel injection equipment						X
57	Checking the technical condition of the starter						X
58	Washing the engine breathers						X
59	Flushing the engine cooling system						X
Maintenance to be performed as required:							
60	Adjusting the oil pressure in the engine						
61	Adjusting the relief valve centrifugal oil filter of the gear-box						
62	Checking/Adjusting the front wheels toe-in						
63	Adjusting external headlights						

Sequence of the Maintenance Operations

The operator shall perform the daily inspection of the tractor for preventing the loosening of the joints, holders and fasteners, leaks of the coolant and oil, for removing the dirtying of the tractor's mechanisms as well as other preventive works for ensuring the tractor operability, fire safety and safety in fulfilling various missions as a part of the machine-tractor aggregate.

ATTENTION! Prior to performing the works for repairing or servicing the tractor, stop the engine and apply the parking-reserve brake.

If the protective shields were removed for performing the works, make sure that they are refitted in place on finishing the works.

NEVER discharge used oils onto the ground. Use special vessels for collecting and storing them. When changing oil, drain it immediately after running the tractor, while the oil is warm.

For checking oil level, place the tractor on a flat level ground.

Prior to performing the maintenance works, remove the engine side panels and raise the bonnet. To do this:

- remove the monocyclon (1) of the air cleaner;
- push down the catch handle (3) and remove the right- and left-hand side panels of the liner;
- pull the bonnet latch handle (2) (found on the left-hand side of the tractor), raise the bonnet (5) and lock it in this position by inserting the supporting stay (4) into the opening of the bracket (6).

ATTENTION! Make sure that the stay (4) is locked securely in the opening of the bracket (6).

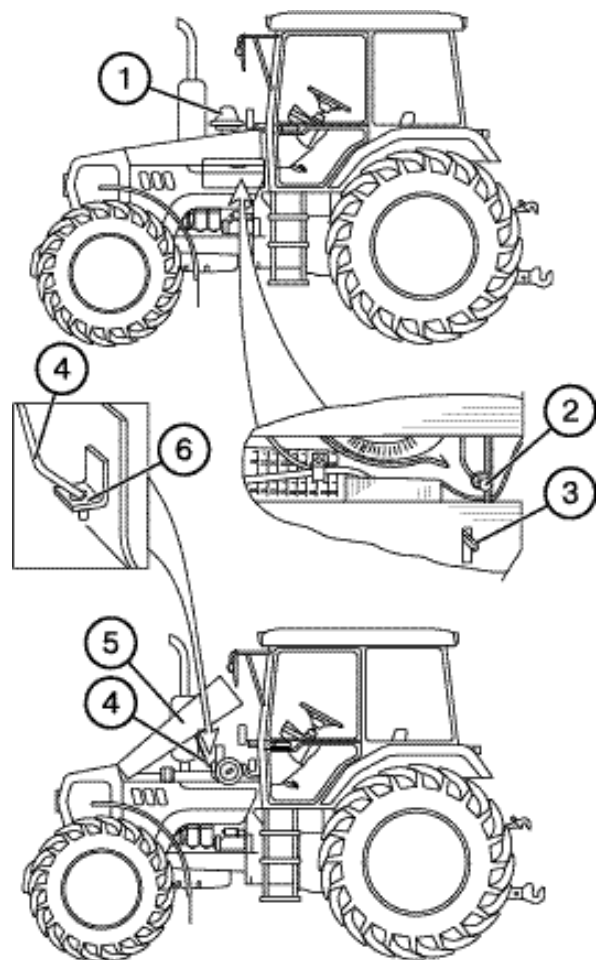

1 – monocyclon of the air-cleaner; 2 – lock handle; 3 – latch handle; 4 – supporting stay; 5 – bonnet; 6 – bracket.

SCHEDULED MAINTENANCE PROCEDURES

After every 10 hours of operation or daily

Procedure 1. Checking the Oil Level in the Engine

Stop the engine, wait for 3...5 minutes and check the oil level. It should be between the top and bottom marks on the dipstick (3). If necessary, remove the cap (2) of the filler neck (1) and add oil to the top mark of the dipstick (3).

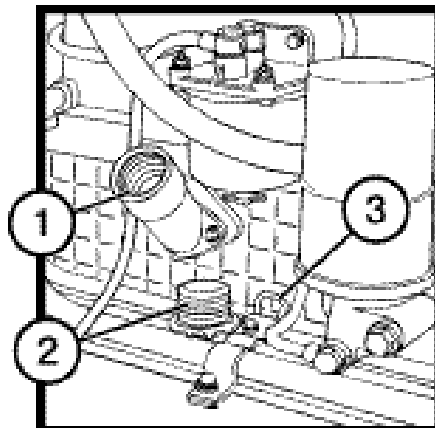

Procedure 2. Checking the Coolant Level in the Engine

Remove the radiator cap and check the coolant level. It should be level with the upper end-face of the filler neck (1). Add coolant to the level, if required.

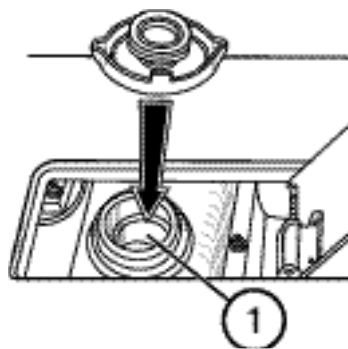

ATTENTION! DO NOT let the coolant level drop below 40 mm from the upper end-face of the filler neck.

IMPORTANT! NEVER fill in the cooling system of the engine with water!

Procedure 3. Checking the Oil Level in the Transmission Housing

Visually check the oil level on the oil-level indicator (3) which is located on the left side of the transmission. The oil level shall be within 10 mm from the mark “П” (“F” – full). If necessary, remove the plug of the oil filler neck and add oil within ± 5 mm from the mark “П”.

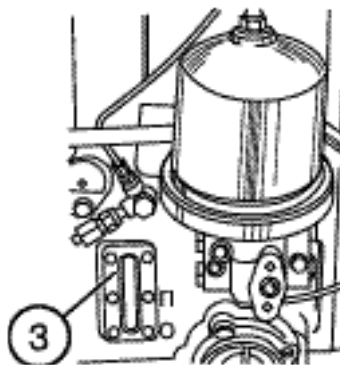

Procedure 4. Checking the Oil Level in the HPS Oil Reservoir

Visually check the oil level against the oil-level indicator (1) located on the HPS tank (to the right-hand side on the clutch casing).

The oil level should be between marks “C” and “П” of the indicator.

If necessary, add oil. To do this, remove the plug (3), together with the valve (2), and add oil up to the mark “C”.

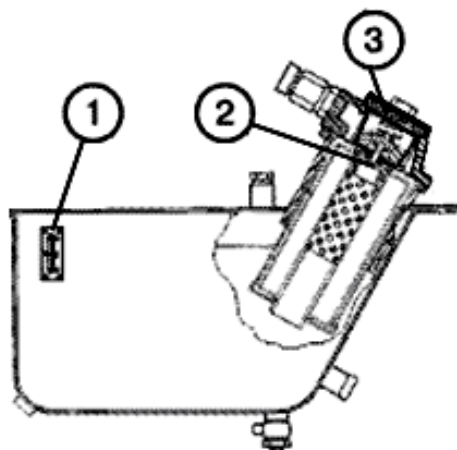

Procedure 5. Checking the Oil Level in the RHL Oil Tank

Check oil level in the oil tank against indicator (1).

The oil level should be between the marks “O” and “П” (“F” – full) of the oil indicator. If necessary, remove the plug (2) of the oil filler neck and add oil up to the mark “П” of the oil-level indicator.

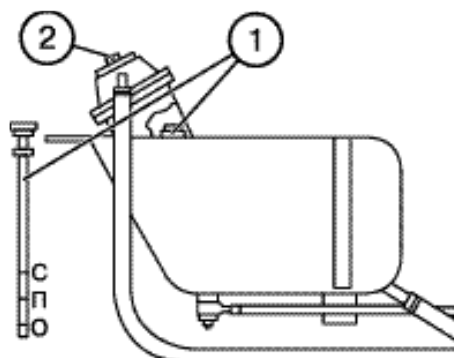

NOTE. With the tractor running in combination with agricultural machines which require elevated consumption of oil, replenish the oil up to the mark “C” of the oil-level indicator.

Procedure 6. Checking the Brake Liquid Level in the Master Cylinder Tanks of the Hydraulic Actuator of the Clutch and Service Brakes

Check visually the liquid levels in the reservoir (4) of the master cylinder of the clutch (located on the left side if viewed in the direction of the tractor forward motion, above the hydraulic system oil tank) and in the reservoirs (1, 2) of the master brakes (on the right side in the direction of the tractor motion, over the HPS oil tank). The level should be within marks “min” and “max” on the boxes. If necessary, add the brake fluid to the “max” marks having unscrewed preliminarily the caps (3).

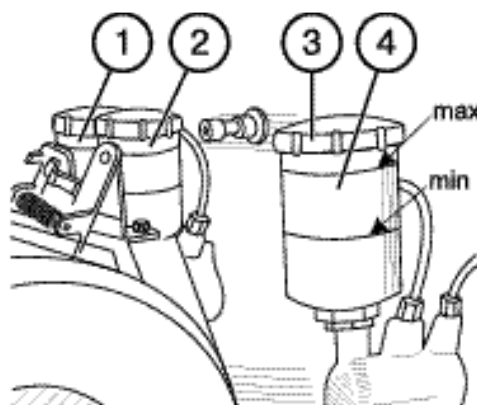

Procedure 6a. Checking the Brake Liquid Level in the Compensation Chamber of the Master Cylinder for Controlling the Clutch and Brakes in the Reverse

The fluid level shall be within the “AND” distance from the upper edge of the compensation chamber. If necessary, remove the boot and add fluid to the required level.

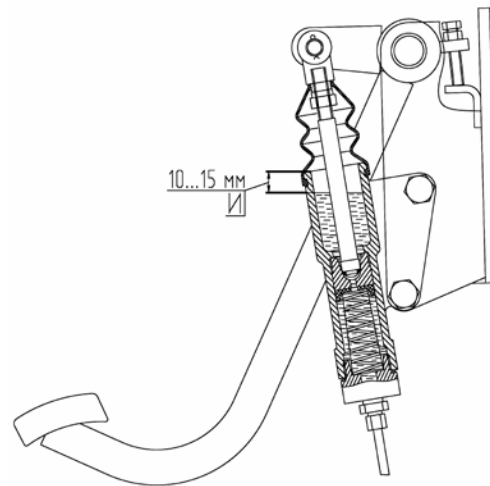

Procedure 7. Draining Condensate From the Hydraulic System Bottle

To drain condensate from the bottle, pull the ring (1) to any side if the bottle contains compressed air. Hold the ring in this position till condensate is completely drained.

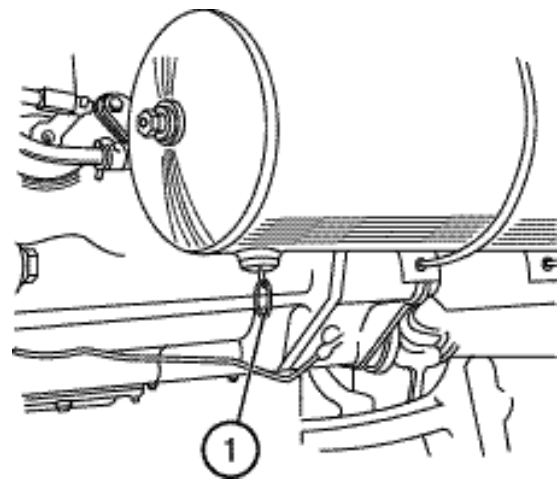

Procedure 8. Checking the Operability of the Engine, Steering Control, Brakes, Lighting and Signalling Devices

The engine shall demonstrate the stable run in all duties.

The controls, light and sound signalling systems should be in good order.

The simultaneous operation of the right- and left-hand service brakes shall be ensured.

Procedure 8a*. Checking the Fastening of the Air-Conditioner Hoses

The air-conditioner hoses shall be reliably fixed by binding screw clamps. No contact of the hoses with the moving parts of the tractor is allowed.

Procedure 8b*. Checking/Cleaning the Air-Conditioner Condenser

Check the cleanness of the condenser core. If it is clogged, clean the condenser using compressed air. The air flow should be directed in perpendicular to the condenser plane top down with the bonnet opened. The crumpled ribbing shall be straightened by means of a special comb or plastic (wooden) plate. In case of heavy contamination of the condenser, flush the latter with hot water under the pressure of 0.15-0.2 MPa and blow it off with compressed air.

Procedure 8c*. Checking the Draining Tubes of the Air Conditioner/Cleaning Them from Condensate

The draining tubes coloured blue are located to the right and to the left from the tube of radiators under the ceiling panel. Check the draining tubes and clean them as necessary to prevent their clogging. The sign of a clean draining tube is water dripping when operating the conditioner in hot weather.

Procedure 8d**. Removing Condensate from the Reservoirs of the Radiator of the Charge Air Cooler (CAC) of the Engine (BELARUS-1523.3/1523B.3)

To remove condensate from the reservoirs of the radiator of the engine CAC, proceed as follows:

- screw out the two plugs (1) in the bottom part of the charge air cooler (2) and let condensate trickle down;

- screw in the plugs (1).

Procedure 8e. Cleaning the Radiator of the Charge Air Cooler (CAC) of the Engine (BELARUS-1523.3/1523B.3)

Check the cleanness of the CAC radiator core. If the radiator core is clogged, clean the same by blowing it off with a compressed air flow directed perpendicularly to the radiator plane top down with the bonnet opened.

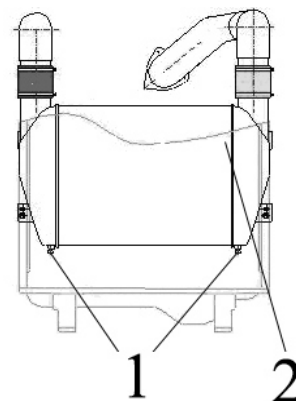

* If the air conditioner is installed.

** In winter, the procedure shall be performed after every 10 hours of operation, in summer – after every 125 hours of operation.

EVERY 125 HOURS OF OPERATION
perform the following procedures:

Procedure 9. Checking/Adjusting the Tension of the Air-Conditioner Compressor Driving Belt

The tension of the belt (3) is considered normal, if sagging of its section between the tensioning lever pulley and the compressor pulley” as measured at the middle point would be within 4 to 6 mm when pushing with the force of (39.2 ± 2.0) N.

The tensioning of the belt (3) for driving the air-conditioner compressor (2) should be adjusted by turning the tensioning lever (1) on the rotating axle (A) and threaded connection clamp (B) in the slot (B) of the plate (Г); the belt sagging when pushing with the force of (39.2 ± 2.0) N applied in perpendicular to the belt section at its middle point shall be within 4 to 6 mm.

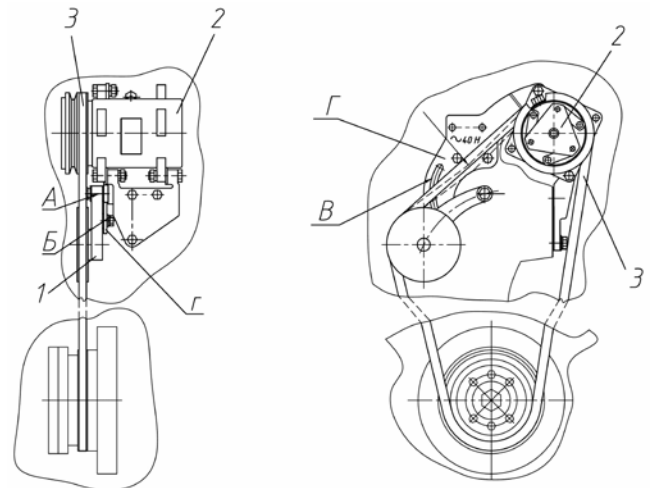

Procedure 9a. Greasing the Pivot Points of the HPS Cylinders

Using a lubricating gun, grease the pivots through the lubricating plugs (2) (4 lubricating points).

Procedure 10. Greasing the Bearings of the FDA Pivot Supports of the Hub Reduction Gear and the Pivot Centre Bushings

- Gun-grease the lubricators (3) by making 4 to 6 strokes (4 lubricating points).
- Gun-grease the lubricator (4) with the above-said lubricant until fresh grease is squeezed through gaps.

5 – pivot centre bushing.

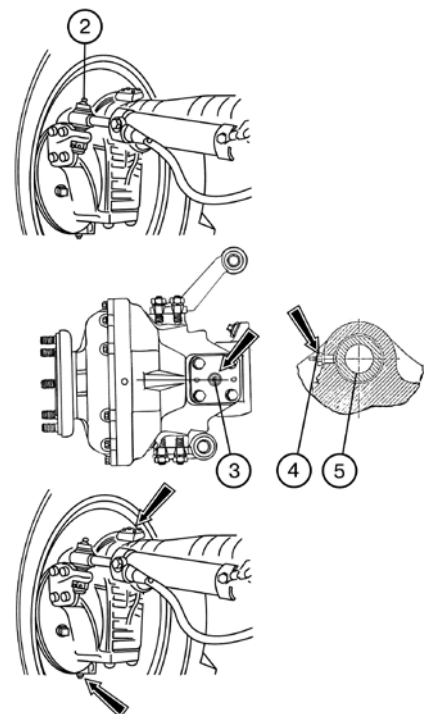

Procedure 11. Draining Sediment and Sludge from the Fuel Tanks and the Fuel Coarse Filter

Screw out the plugs (1, 4) and drain sediment and sludge from the fuel tanks (2) and filter (3), respectively until clear fuel appears. Screw in the plugs.

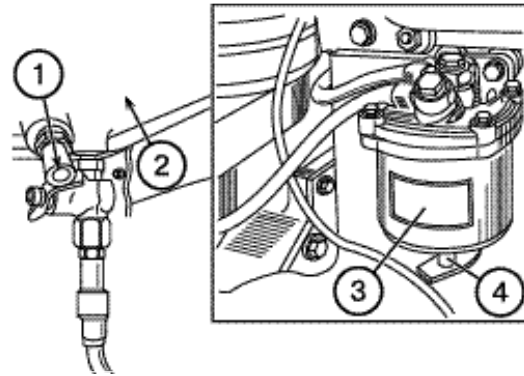

Procedure 12. Checking the Tension of the Alternator Driving Belt

The alternator belt tension is considered to be correct if its sagging at the section between the pulleys of the crankshaft and the alternator is within 29 to 33 mm when pushed with a force of 40 N (4 kgf). To adjust the belt tension, turn the alternator body such as to ensure the required tension. Tighten the plate attachment bolt and nuts of the alternator attachment bolts.

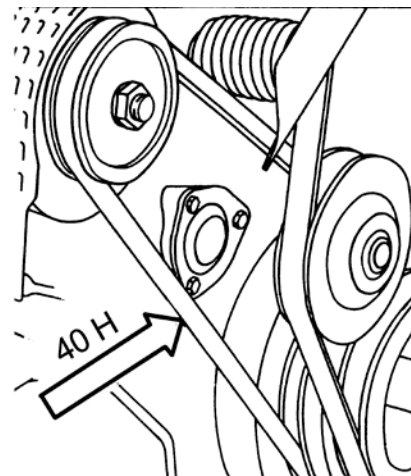

Procedure 13. Checking the Tyre Inflation Pressure

Check the condition of the treads and air pressure in the tyres. If necessary, bring the pressure to the norm in accordance with a number of loads and pressures (see Section "Aggregating the Tractor with Agricultural Machines and Implements").

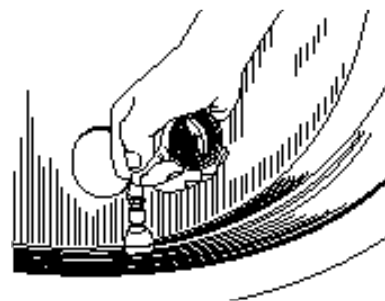

Procedure 13a. Checking the Tightening of Fasteners of the Hubs and Wheels

Check the tightening torques and, if necessary, tighten up:

- the bolts (1) of hubs of the rear wheels with the torque of 360...500 N•m;
- the nuts fastening the rear wheels to the hubs – 300...350 N•m;
- the nuts fastening the front wheels to the flanges – 200...250 N•m;
- the nuts fastening front wheel webs to the rim carriers – 180...250 N•m.

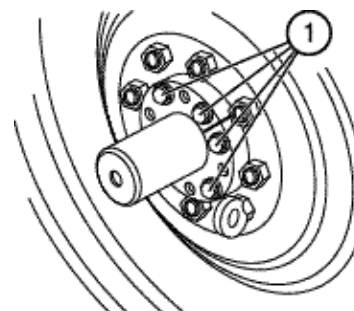

Procedure 14. Adjusting the Clutch Control Mechanism

The adjustment of the clutch control mechanism is described in Section “Construction and Operation”, пункт “Clutch Control Adjustment”.

Procedure 15. Checking the Engine Air Cleaner

Check the condition of the paper filter elements (PFE) for paper rupture and correct insertion.

To check the basic filtering element (BFE), proceed as follows:

- screw out the butterfly nut (2) and remove the sump (1);
- screw out the butterfly nut (3) and remove the BFE (5);
- check the monitor filtering element (MFE) (4) for contamination without withdrawing it from the housing (6).

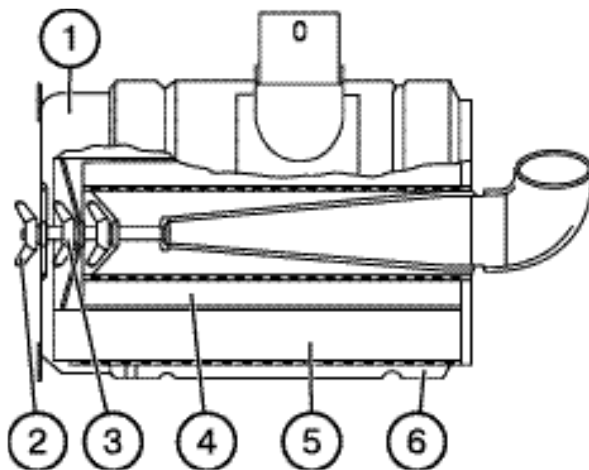

ATTENTION! It is not recommended to take the filter element (4) from out of the housing (6).

NOTE: Under heavy dust-laden conditions, this procedure should be performed every 20 hours of the engine operation.

Contamination of the monitor filter element is indicative of a damaged basic filter element (BFE) – rupture of the paper shutter, unstuck bottom. In this case, flush the MFE and replace the BFE.

Procedure 15a. Clean the Filter of the Cab Ventilation and Heating System

ATTENTION: Under the conditions of high moisture of the environment, do not switch off the fan before cleaning the filters, because it is difficult to remove dust from the moist paper filtering element.

The filters of the ventilation system are fitted on the both sides of the tractor cab.

To clean the filter of the cab ventilation and heating system, proceed as follows:

- to gain access to the filter, use a stand or small ladder;
- turn out two screws with plastic heads (1) under the projecting edge of the cab;
- remove the panel (2) and remove the filter (3);
- shake dust out of the filter by slight tapping so that not to damage the paper filtering element;
- clean the filter using compressed air under the pressure of not more than 0.1 MPa. The hose nozzle shall be held at the distance of not less than 300 mm from the filter to prevent the damage of the paper filtering element. It is necessary to direct the air flow through the filter in the direction opposite to the normal air flowing shown by the arrows marked on the filter.

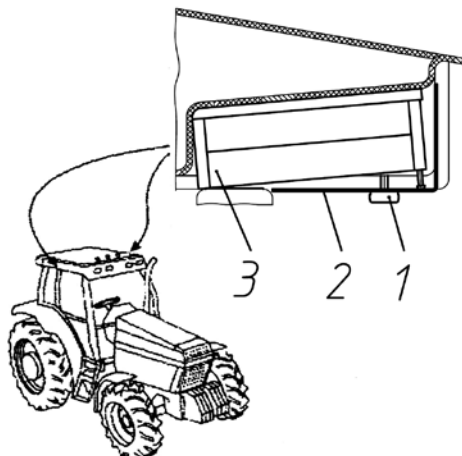

ATTENTION: If the tractor is operated under the heavy dustiness conditions, clean the filter after every 8-10 hours of operation, i.e. after every shift.

Procedure 15b. Checking the Tightening of the Bolts of the CAC Air Ducts (BELARUS-1523.3/1523B.3)

Check and tighten the bolts of the clamps of the air CAC ducts as necessary. The torque of tightening the said bolts shall be 10 to 15 N·m

ATTENTION: After checking the tightening of the bolts of the clamps, it is necessary to check all the intake duct connections for leak-tightness. To do this, it is necessary to perform the inspection for damages and loss of tightness of the connections of all the air ducts and silicon branch pipes of the air cooling system. Should any faults or damages be revealed when performing the check, it would be necessary to ascertain their causes and take measures for eliminating them!

NEVER operate the tractor with faulty charge air cooling system!

AFTER EVERY 250 HOURS OF OPERATION, perform the previous maintenance procedures plus the followings:

Procedure 16. Greasing the Clutch Release Bearing

Screw out the plug (1) on the left side of the clutch housing, insert the point of a plunger-and-lever gun into the hole and make four to six strokes through the pressure lubricator. Refit the plug (1).

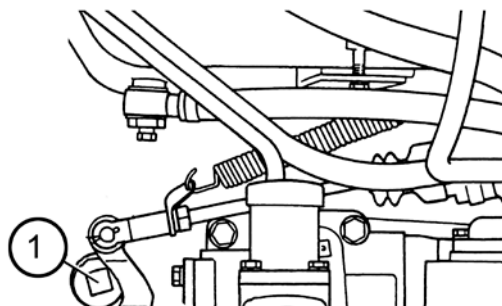

Procedures 17, 18. Cleaning the Rotors of the Centrifugal Oil Filters of the Engine and Gear-Box, Respectively

Screw out the nut (1) and remove the shell (2). Remove the inner cup (3) by means of a wrench (4) and a screwdriver (5). Remove the cover (6), impeller (7) and filter (8). Wash the screen (8) in diesel fuel. Remove a layer of sediment from the inner walls of the inner cup of the rotor (3).

Apply a film of motor oil on the rubber sealing ring. When reassembling, align the marks on the inner cup with those on the rotor body. Tighten the nut (1) with applying the torque of 35 to 50 N·m.

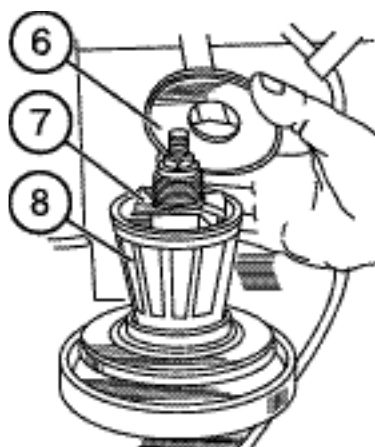
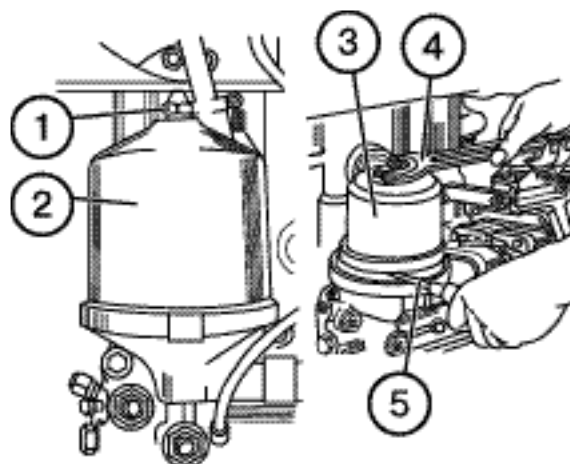

ATTENTION! The engine and gear-box filters are considered to be operating properly, if a light noise of rotating rotors can be heard for 30...60 seconds after the warmed up engine has been stopped.

Procedure 19. Washing the Screen Filter in the Gear-Box Hydraulic System

Screw out the cover (1) of the screen filter and take the filter assembly by the cramp (4).

Disassemble the filter by screwing off in turn the locknut (2) and the cramp (4) together with the stud (9). Remove the plate (1), spring (6), piston (5), sealing ring (7) and filter elements (8). Wash all the components in diesel fuel to remove dirt completely. Reassemble the filter in the reverse order of operations; pay special attention to fitting rings (7) on both sides of the set of filter elements.

ATTENTION! The cramp (4) should be screwed on the stud (9) before setting the plate (1) flush with the piston (5) end-face.

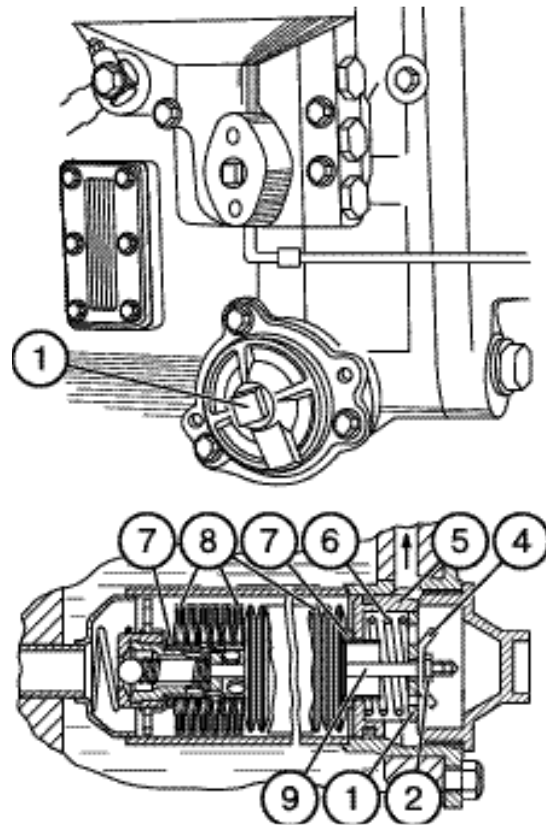

Procedure 20. Changing Oil in the Engine Crankcase

- Warm up the engine to normal operating temperature (at least 70°C).
- Place the tractor on a flat level ground, stop the engine and apply the brake.
- Remove the oil filler neck cap (2) and screw out the drain plug (4). Drain oil in a container suitable for oil storage.
- Refit the drain plug (4) and pour fresh clean engine oil through the oil filler neck (1) up to the mark of the oil dipstick (3).
- Refit the filler neck cap (2).
- Start the engine and let it run for 1-2 minutes.

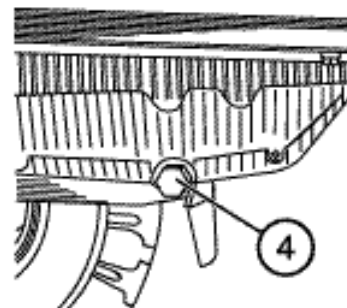
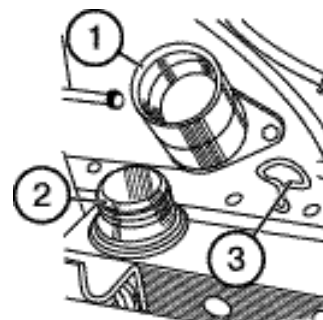

- Check oil level with the dipstick (3), as described under Procedure 1.
- If necessary, add oil to the level.

Procedure 21. Changing the PFE of the Engine Oil Filter (to be performed simultaneously with changing oil in the crankcase):

- Screw out the cap shell (5) in unit with the paper filter element (6) as assembly.
- Screw out the nut (1) and remove the bottom (2) together with gaskets (3) and (9).
- Press the clamp (4) inside the cap (5) to the distance of 3 to 4 mm and then turn it in such a way as to align the bosses of the clamp (4) with the slots of the cap (5).
- Remove the clamp, PFE (6), bypass valve (7) and spring (8).
- Wash all the parts in diesel fuel.
- Install a new filter element following the above operations in the reverse order. If required, replace the gaskets (3) and (9). Tighten the nut (1) with applying a torque of 30...40 N·m. Apply a film of engine oil onto the gasket (9).
- Screw in the assembled filter additionally by 3/4 revolutions after the gasket (9) comes in contact with body (10).

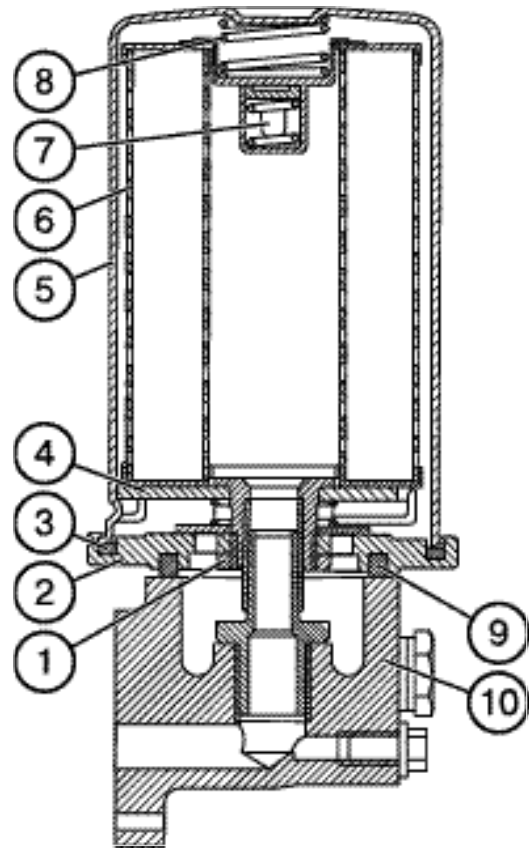

ATTENTION! Screw in the filter exclusively by hand effort, holding it by the filter cap (5).

Procedure 23. Checking Oil Level in the Front PTO Reduction Gear-Box (if installed)

Screw out the plug (1) of the check-and-filler hole (on the right side of the reduction gear-box). The oil level shall be up to the threaded hole for the plug.

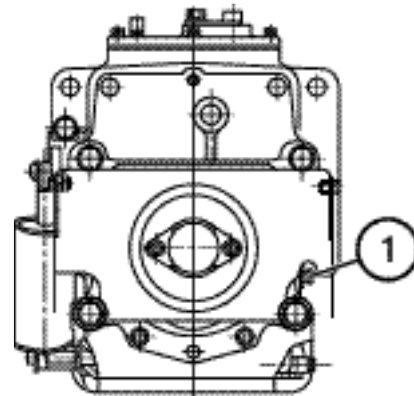

Procedure 24. Checking the Front Wheels for Toe-In

The front-wheel toe-in shall be within 0 to 8 mm.

If necessary, perform the adjustment (refer to Procedure 62).

Procedure 25. Checking the Oil Level in the Final Drive and Hub Reduction Gear Housings

Check the oil level:

- **In the hub reduction gear-box casings (left- and right-hand).** Add oil, if required, to the level of the check-and-filler hole stopped with the plug (2).
- **In the final drive of the FDA with removable housings.** Add oil, if required, up to the level of the check-and-filler hole stopped with the plug (1).

Grades of oils to be used:

Transmission oils Тал-15В, ТСп-15К, ТСп-10 or ТАД-17и.

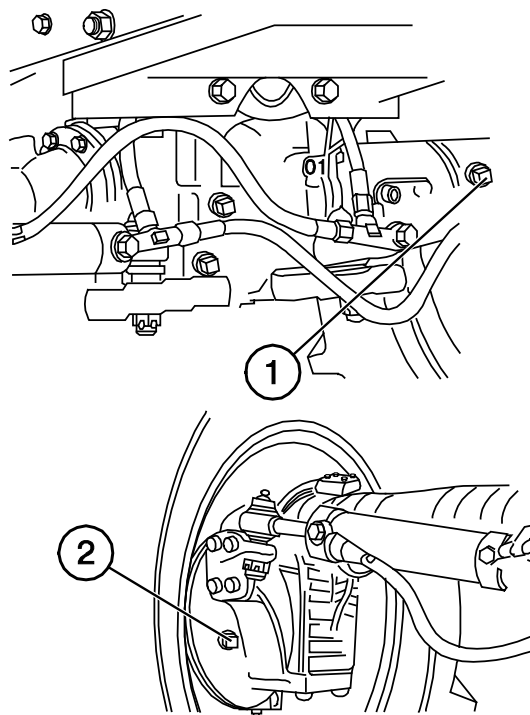

Procedure 26. Turbocharger

Check the fasteners of the turbocharger (1), outlet ducts (3) and the exhaust pipe (2) bracket for tightness. Tighten up with applying a torque of 35...40 N·m, if required.

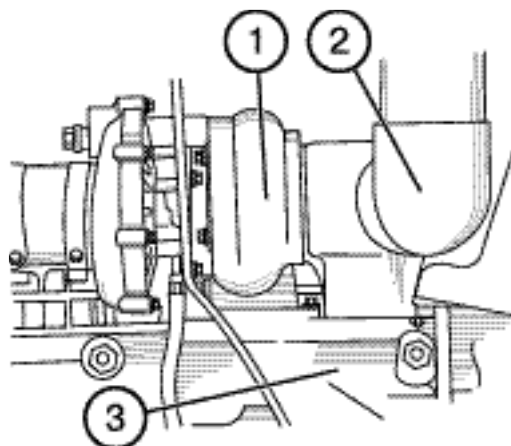

AFTER EVERY 250 HOURS OF OPERATION, perform the previous maintenance procedures plus the followings:

Procedure 27. Checking the clearances between the valves and the rocker arms

Note: The clearances should be checked on a cold engine, having checked preliminarily the cylinder head bolts tightening (Procedure 42).

- Remove the covers of the cylinder heads.
- Check the tightening of the bolts and nuts which fasten the rocker-arm shaft brackets (60...90 N·m).
- Turn the crankshaft until the piston of the first cylinder comes to a valve lap position (where the inlet valve starts to open, while the outlet valve completes the closure).
- Adjust clearances in 3, 5, 7, 10, 11 and 12 valves (to be counted from the fan).

ATTENTION! The clearances between the end-faces of the valve stems (2) and the rocking arm heads (3) shall be 0.25...0.30 mm for the inlet valves and 0.40...0.45 mm for the outlet valves.

- Turn the crankshaft through 360°, first having set the valve lap in the sixth cylinder; then, adjust the clearances in valve Nos. 1, 2, 4, 6, 8 and 9.

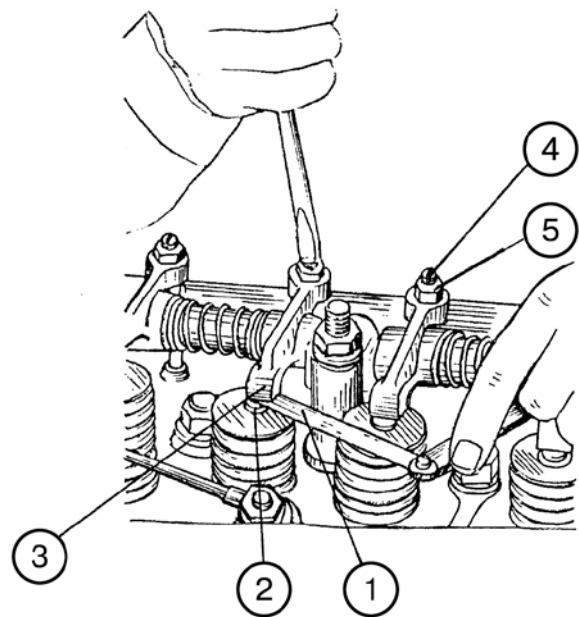

- To adjust the clearance, slacken the locknut (5) of the adjusting screw (4) and set the required clearance against a clearance gauge (1) by means of a wrench and driver. After setting the clearance, tighten the locknut and re-check the clearance using the gauge.
- On completion of the adjustment job, refit all the parts removed.

Procedure 28. Draining Sediment and Sludge from the Fuel Fine Filter

- Turn out the air-bleeding plug (1) which is located on the filter housing by 2...3 revolutions. First, screw out the sediment and sludge draining plug (2) on one shell which is located at the bottom, and drain the sediment until a clear jet of fuel appears. Then, screw out the plug on the second shell and drain the sludge. Screw in the plugs.
- Bleed air from the fuel system (refer to Procedure 48).
- **When a fuel fine filter (FFF) with one filter element is installed:**
 - Loosen the air bleeding plug (1) by 2...3 revolutions.
 - Screw out the sediment/sludge drain plug (2) and drain the same from the filter housing until a clear jet of fuel appears. Tighten the plugs (1) and (2).
 - Bleed air from the fuel system.

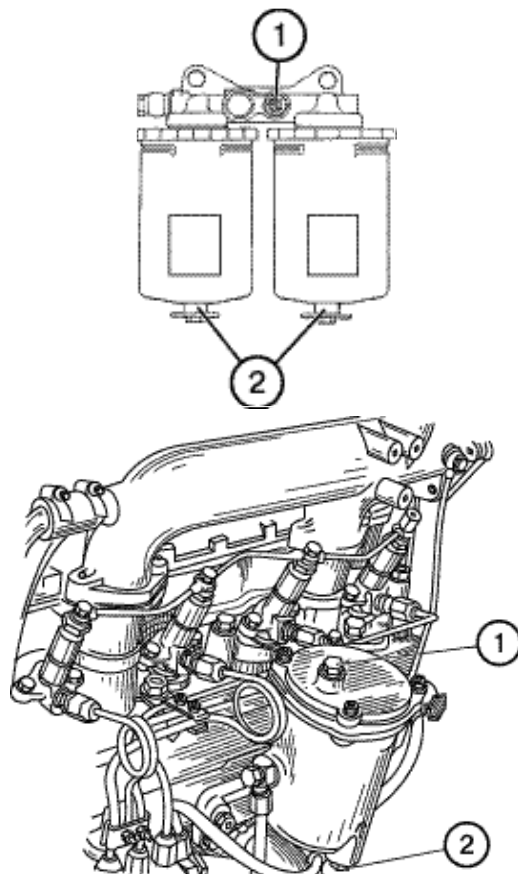

Procedure 29. Checking the Steering Controls for Play

If the steering wheel play exceeds 25°, take up looseness in the steering trapezoid pivots, tighten the nuts of the steering knuckle arms, and eliminate plays in the steering column and steering gear.

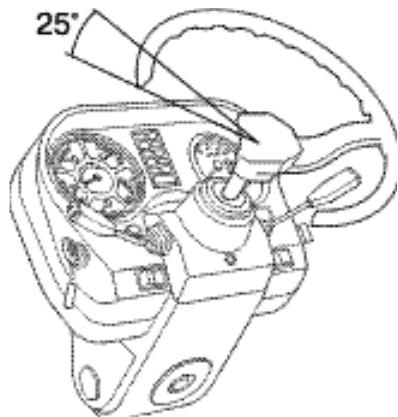

Procedure 30. Checking the Clearances in the Bearings (Flanges) of the Front Wheels

Check the taper roller bearings (2) of the flange (3) and adjust them as required by means of the nut (1) to a no-gap condition. Tighten up the nut so that the gap is taken up completely, then prick-punch the nut in two slots in the flange (3).

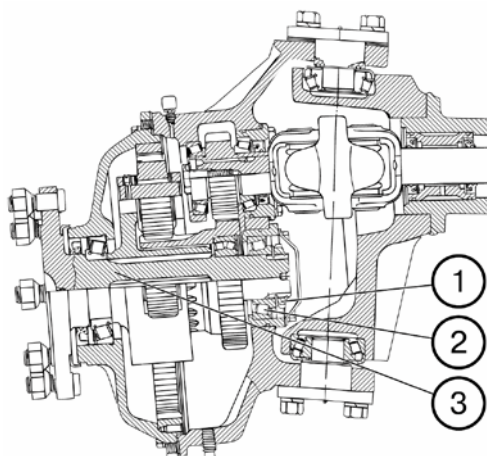

Procedure 31. Adjusting the Travel of the Brake Pedals and Parking Brake Lever

The adjustment of the travel of the brake pedals and parking brake lever is described in Section “Construction and Operation”.

Procedure 32. Servicing the Storage Batteries

Clean the storage batteries from dust and dirt. Remove the plugs (1) of the storage battery filler openings, check the electrolyte level and, if necessary, top up with distilled water so that the electrolyte level would exceed that of the protective separators by 12...15 mm or be between the check marks on a transparent battery compartment. Check the condition of the terminals (2) and vent holes in the plugs. Smear the terminal, if necessary, with technical petroleum jelly and clean the vent holes.

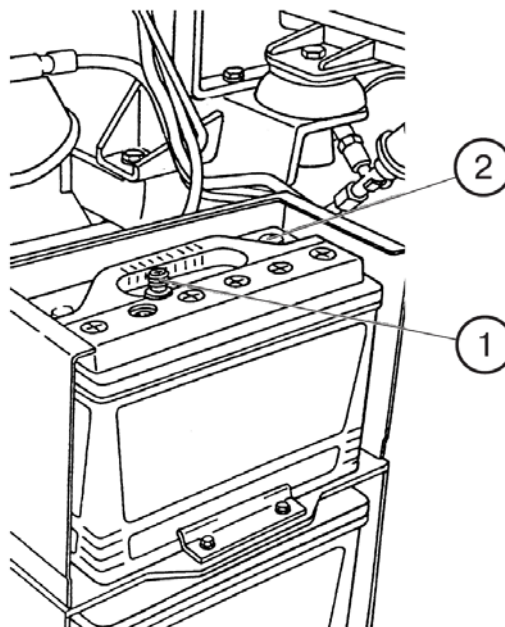

Procedure 33. Changing the Replaceable Filter Element in the Hydraulic System Oil Tank

- Screw out the bolts (1) fixing the cap (2) and remove the cap assembled with the valve (3);
- Remove the filter element (4);
- Clean the inner chamber of the barrel (5);
- Install a new filter element, refit the cap assembly (2) and tighten the bolts (1).

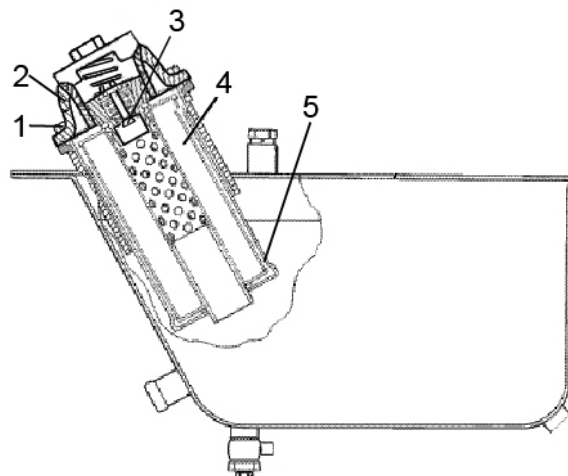

Procedure 33. Replacement of the Filter Element of the HPS Oil Tank

- Screw out bolts (3) fixing the cap (4) and remove the cap assembled with the plug (5) and valve (6);
- Take the filter element (2) out;
- Очистите внутреннюю полость стакана (1);
- Clean the inner chamber of the barrel, refit the cap assembly (4) and tighten the bolts (3).

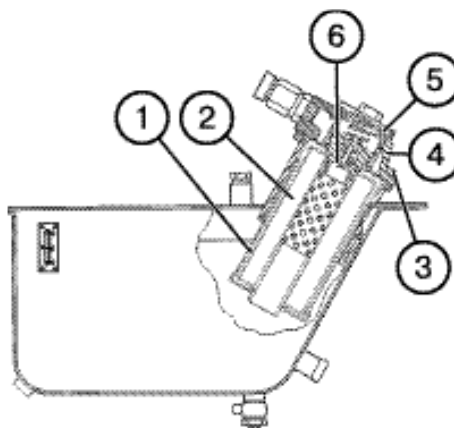

NOTE: All further replacements of the filter elements should be carried out every 1000 hours of operation, simultaneously with the change of oil in the HPS oil tank.

Procedure 35. Checking the Alternator Fastening Bolts for Proper Tightening

Clean the alternator from dust and dirt. Check the fastening bolts for tightness and reliable fixation of the electric wiring terminals.

Procedure 36. Check the Plays in the Steering Link Joints (in case of installation of the FDA with two hydraulic cylinders of the HPS)

With the engine running, turn the steering wheel in both directions for checking the free travel and play in the joints (1) of the steering link (4).

Should there be any plays in the joints, proceed as follows:

- Remove the locking wire (3);
- Screw in the threaded plug (2) to eliminate the clearance in the articulated joint;
- Lock the plug with wire (3).

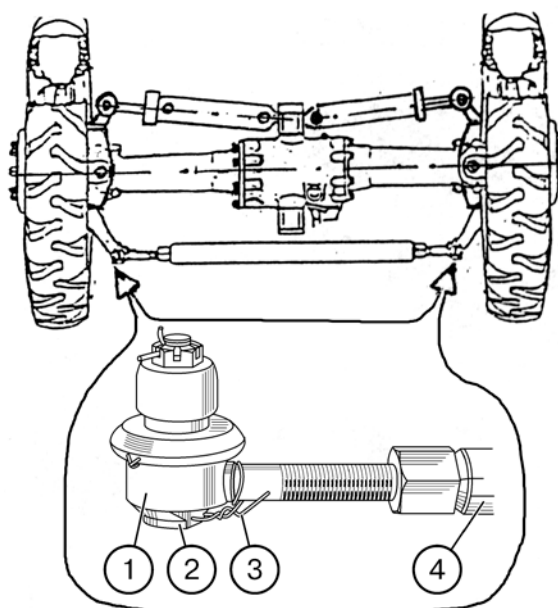

Procedure 37. Checking the Joints of the Air Cleaner and the Engine Intake Duct for Tightness

- Remove the monocyclon, start the engine;
- Set a medium rotational speed of idling;
- Block the intake pipe (1) of the air cleaner. The engine shall stall in this case;
- If the engine is still running, locate and remove leaks in the air cleaner and intake duct joints.

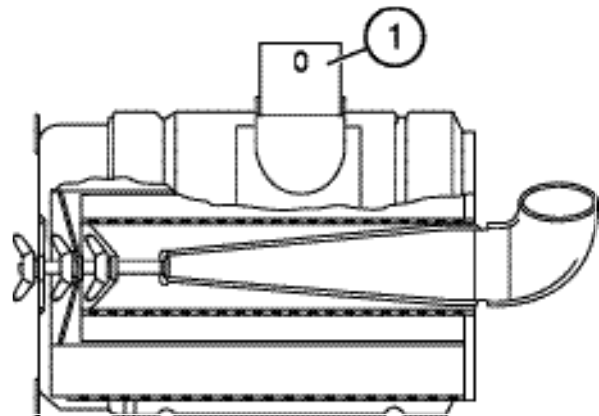

Procedure 38. Checking the Pneumatic System for Leak-Tightness

The air pressure drop in the pneumatic system shall not exceed 200 kPa for the period of 30 minutes with the brake controls in a released state and compressor switched OFF.

The air pressure in the bottle, which is maintained by a regulator, shall be within 600...850 kPa.

Procedure 39. Checking the Bolts of Clamps of the CAC Air Ducts for Tightening

Check, and tighten as necessary the bolts of clamps of the CAC air ducts. The torque of tightening of the bolts of clamps of the CAC air ducts shall be 10 to 15 H·m.

Procedure 40. Changing Oil in Oil Tank of the RHL Hydraulic System

At a working temperature of oil in the oil tank of the hydraulic system:

- screw out the filler neck plug (1);
- screw out the drain plug (3) and drain oil from the oil tank into a vessel prepared in advance;
- screw in the plug (3), pour fresh oil up to the mark "П" ("F" – full) on the dipstick (2); refit the plug (1) back to its place.

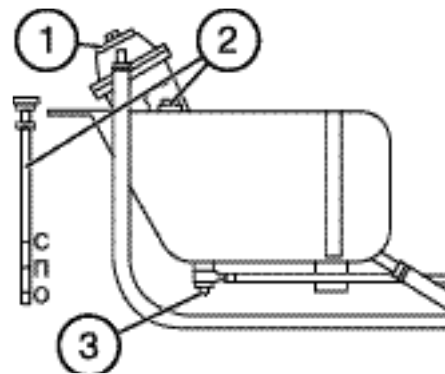

Procedure 41. Checking the Play and Preload in:

1. Bearings of the Hub Reduction gear Driving Pinion (3):

- Check and adjust as necessary the bearings (1) of the driving pinion (2) to a gap or Preload of not more than 0.05 mm. The adjustment shall be carried out with the help of slit shims (3) to be inserted between the bearing cage (5) and the housing (4).

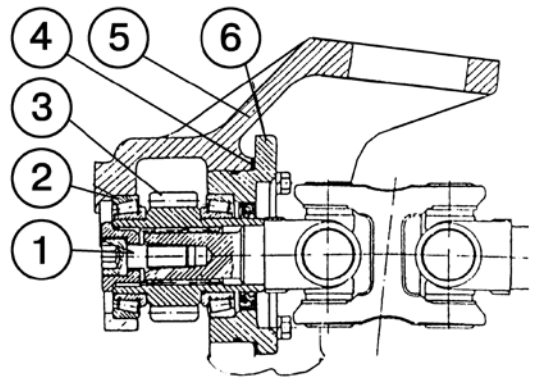

2. Bearings of Pivot Axles (3):

- The preload in the bearings shall be such as to allow a knuckle turn effort of within 60...80 N to be applied to the flange (5). If necessary, perform adjustment as follows:
 - screw out the four bolts (2) and screw in instead two dismantling bolts into the specially drilled auxiliary holes of the axle (3);
 - remove the required number of shims (4) on both sides;
 - screw out the dismantling bolts and tighten the bolts (2) with applying a torque of 120...140 N·m.

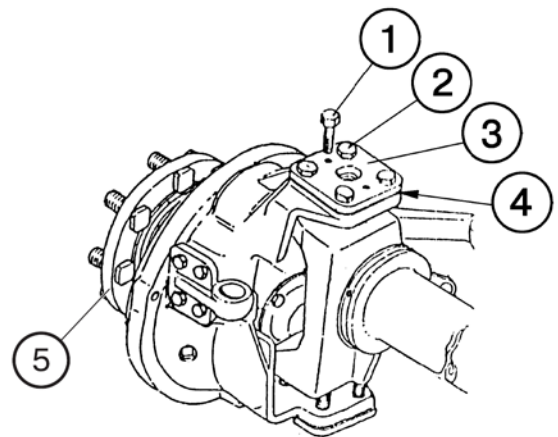

Procedure 41a*. Replacement of the Drying Filter

ATTENTION: For replacing the drying filter, it is necessary to contact the specialized service station. The replacement can be only performed with the use of special equipment.

* The procedure shall be performed after every 800 hours or once a year

AFTER EVERY 1000 HOURS OF OPERATION perform the previous maintenance procedures plus the followings:

Procedure 42. Checking the Bolts Fastening Two Engine Cylinder Head for Proper Tightening

The bolts should be tightened on a warmed-up engine in the following sequence:

- Remove the hoods and covers of the cylinder heads;
- Remove the rocking arm shafts with the rocking arms and brackets;
- Check the tightening torque of all the bolts by means of a dynamometric wrench in the sequence shown in Fig. on the right (for the sake of simplicity, only one cylinder head is shown). The torque should be within 190...210 N·m (19...21 kgf·m) limits.

On finishing the tightening operation, refit the rocking arm shaft; check and re-adjust as necessary the valve-to-arm clearances (refer to Procedure 27).

Procedure 42a. Changing the Brake Fluid in the Clutch and Brake Actuators

Clutch Actuator:

- Remove the protective cap (28) (see Section "Construction and Operation", figure in item "Clutch Actuator") and draw a rubber hose onto the head of the bypass valve (29) having put another end of the hose into a vessel;
- Turn the valve (29) by one revolution;
- Step on the clutch pedal for forward motion several times, until the brake fluid is removed completely from the system;
- Step on the clutch pedal for reverse motion several times, until the brake fluid is removed completely from the system;
- Pour fresh brake fluid and bleed air from the hydraulic clutch control system for the forward and reverse motion (see Section "Construction and Operation",

item "Bleeding the air from the hydraulic clutch control system").

Brake actuator:

- Remove the protective cap and draw a rubber hose onto the head of the bypass valve of one of the service brake cylinders 16, 19 (see Section "Construction and Operation", item "Hydraulic Brake Actuator of the BELARUS-1523B/1523B.3 Tractor) having put another end of the hose into a vessel;
- Turn out the bypass valve by one revolution;
- Step on the interlocked brake pedals (5, 6) for forward motion several times, until the brake fluid is removed completely from the system;
- Step on the reverse pedal (2) of the master brake cylinder of reverse (3) for reverse motion several times, until the brake fluid is removed completely from the system;
- Repeat the above procedure for the second service brake cylinder.
- Pour fresh brake fluid and bleed air from the hydraulic brake actuator system for the forward and reverse motion.

Procedure 43. Checking the External Bolted Joints for Proper Tightening

Check the tightening of and tighten as required the external bolted joints of the tractor, front and rear wheels; front mud-guards brackets; front beam of the semi-frame; the joints between the engine and the clutch housing; between the clutch housing and the speed gear-box; between the speed gear-box and the rear axle housing; between the rear axle housing and the top cover; between the front and rear supports of the cab; the nuts of the front driving axle; the bolts of the universal-joint flanges; the bolts of the axle-shaft housings and the bolts of the haul-and-draw coupler.

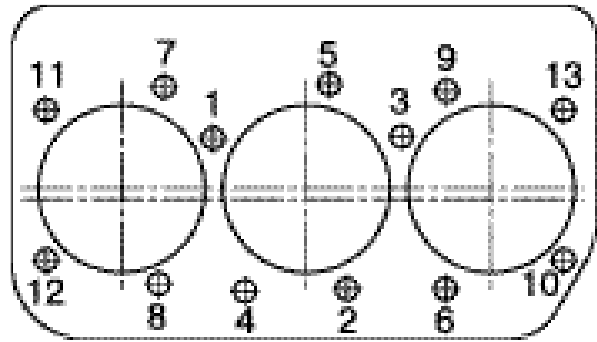

Procedure 44. Cleaning the Fuel Coarse Filter

- Clean the external surface of the filter, screw out the nuts (1) fastening the cup; remove the cup (3) and screw off the deflector (2) with the screen. Remove the deflector.
- Wash the deflector together with the screen (2), the scatterer and the inner chamber of the cup (3) in diesel fuel.
- Reassemble the filter in the reverse order and prime the fuel system (refer to Procedure 48 below).

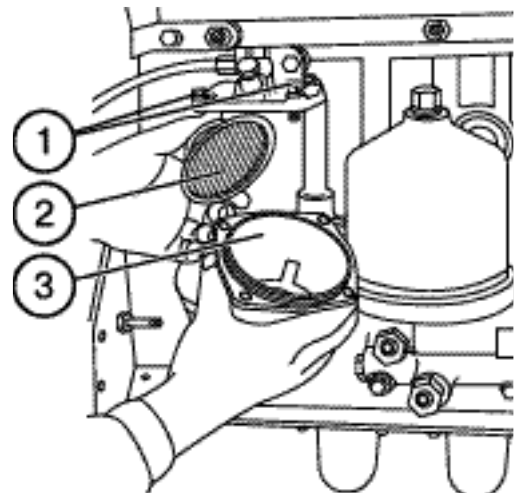

Procedure 45. Washing the Turbocharger

Dismount the turbocharger from the engine and, without disassembling it, immerse it into kerosene or diesel fuel; then blow through it with compressed air, dry and reinstall it on the engine.

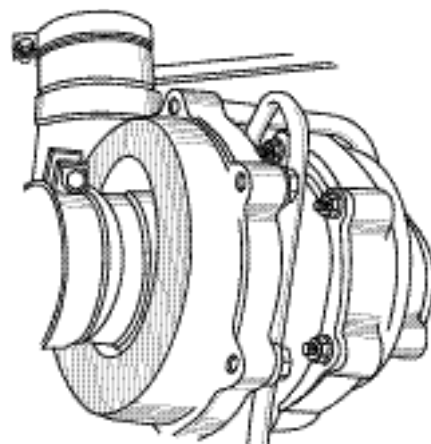

Procedure 46. Changing Oil in the Transmission Housing

1. Run the tractor and warm up oil in the transmission.
2. Remove the filler neck plug (2) located on the on the right side of the clutch housing.
3. Screw out the drain plugs (1) of the transmission and the plugs (3) of the axle-shaft housings.
4. Discharge oil from the transmission into a special vessel for collection and storage of waste oils.
5. Refit the drain plugs back in place and fill in fresh oil up to the mark “П” (“Full”) against the oil-level indicator (refer to Procedure. 3). Refit the plug (2).
6. Run the tractor for 5...10 minutes and check the oil level. Add oil to the level, if necessary.

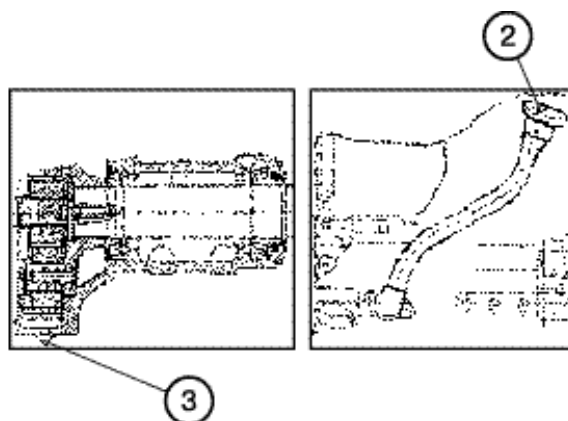
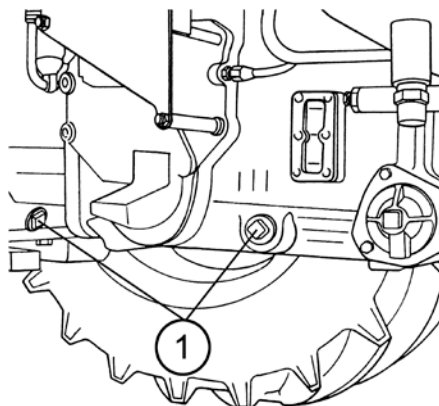

Procedure 47. Changing Oil in the HPS Oil Tank

At the working temperature of oil in the oil tank, proceed as follows:

- screw out the filler neck plug (2);
- screw out the plug (3) and discharge the oil into a special vessel prepared beforehand;
- screw in the plug (3), fill in fresh oil up to the mark “C” against the oil-level indicator (1); place the plug (2) back in place.

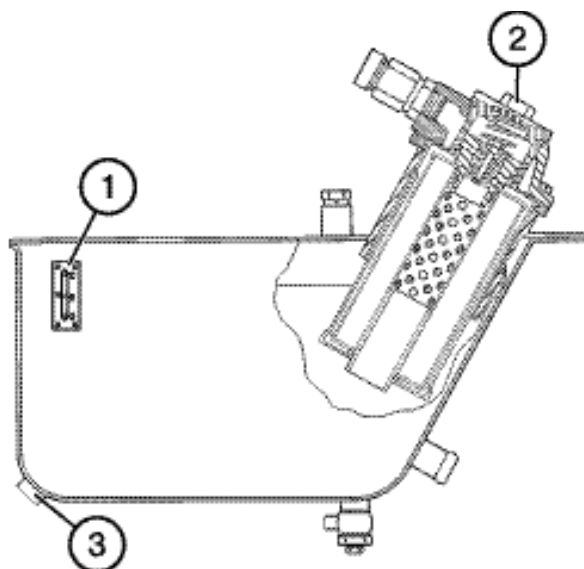

Procedure 48. Changing the Filter Element in the Fuel Fine Filter

- Screw out the filters (1) as assembly.
- Disassemble each filter (1) having performed the following procedures:
 - turn out the nut (5) and remove the bottom (3) together with the rings (2) and (4);
 - press the clamp (6) inside the cap (8) by 3 to 4 mm and then until the bosses of the clamp are aligned with the slots of the cap;
 - remove the clamp (6), PFE (7) and spring (9) from the cap (8);
 - Wash the internal chambers of the caps and all the parts of the filters in diesel fuel.
- Replace the filter elements by new ones and reassemble the filters in the reverse order.
- Check the condition of the rings (2) and (4) and replace them, if necessary.
- Tighten the nut (5) with applying the torque of 30... 40 N•m.

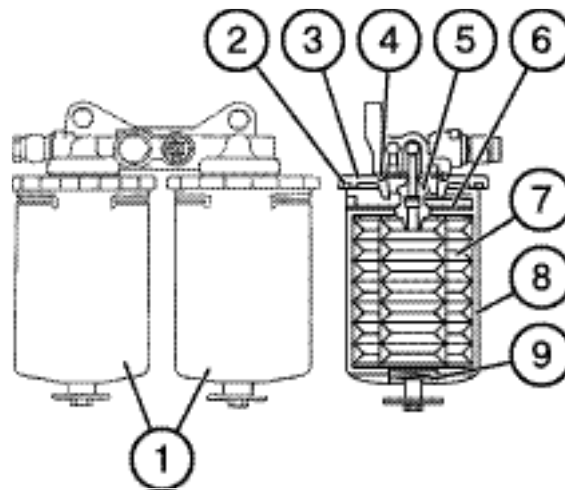

- Lubricate the ring (4) with engine oil and screw in each filter by 3/4 revolutions after the ring (4) comes in contact with the filter body.

IMPORTANT! Screw the filters as assembly (1) into the housing with the hand torque.

In case of installation of a single FFF unified with the Д-243 engines:

- Screw out the plug (3) and drain the sediment.
- Turn out four nuts and remove the cap (1).
- Pull the filter element (2) from the housing and discard it.
- Wash the housing and cap in clean diesel fuel.
- Check the seal of the cover and replace it, if required.
- Install a new filter element.
- Screw in the plug (3).
- Refit the cover and fastening nuts.
- Open the fuel tank tap and prime the fuel system.

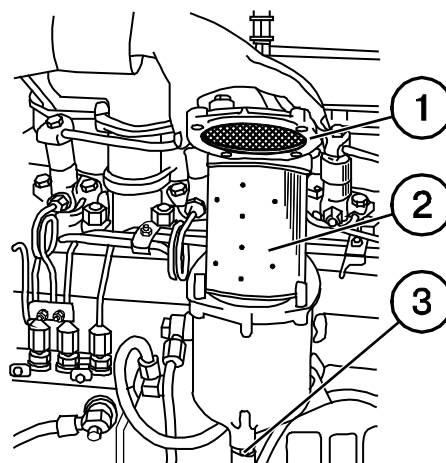

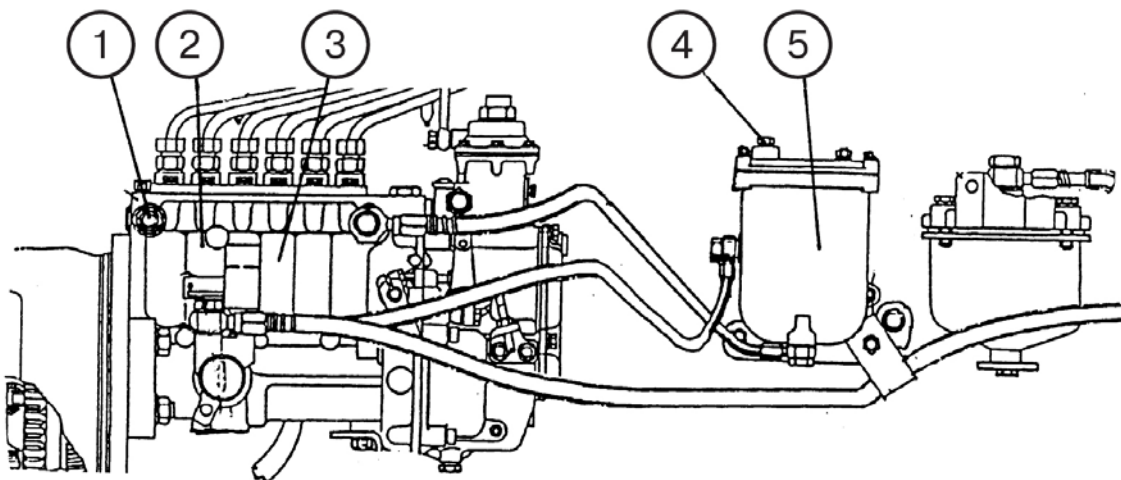

- Bleed air from the fuel system. To do this, proceed as follows:
 - screw out the plug (1) by 2...3 revolutions for bleeding air from the fuel pump (3);
 - screw out the plug (4) on the housing of the fuel fine filter (5) by 2...3 revolutions;
 - bleed air from the fuel system by means of the hand booster pump (2) with screwing in consequently the plug (4) on the fuel fine plug and then the plug (1) on the fuel pump when fuel without air bubbles

will appear. Screw on the handle of the hand booster pump.

Procedure 49. Checking the alternator

Remove the driving belt (1) from the alternator pulley (2) and check the easiness of rotation and the presence of plays in the rotor bearings. Should there be any plays and jamming of the rotor, dismantle the alternator and send it to the workshop for repair.

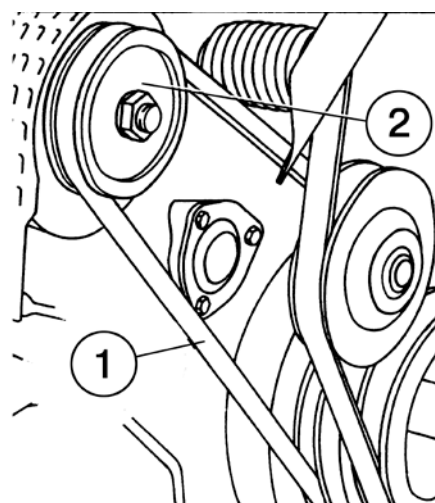

Procedure 50. Changing Oil in the FDA Hub Reduction Gear-Box and Final Drive

- Run the tractor for some time and warm up oil in the FDA housings.
- Place the tractor on a flat level ground. Stop the engine. Set the parking brake and wedge the wheels on both sides.
- Remove the check-and-filler plugs (2, 6) and the drain plugs (1, 5). Discharge the oil in a special vessel for collection and storage of waste oils. Be sure to dispose of the oil in the established manner.
- Refit the drain plugs (1, 5) and **затяните их.**
- Fill in the housings with fresh transmission oil to the lower edge of the check-and-filler necks.
- Refit and tighten the plugs (2, 6).

NOTE: The oil should be also changed when performing the seasonal maintenance.

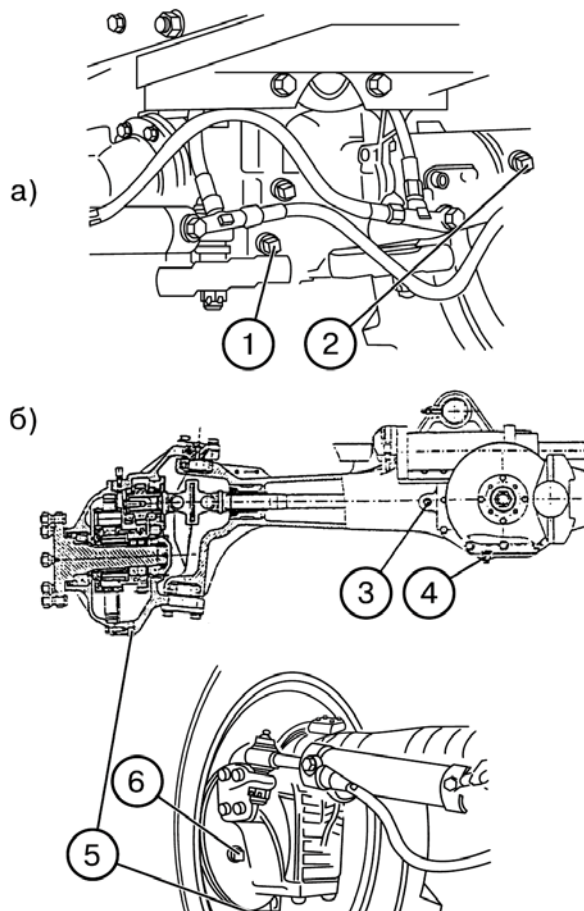

Procedure 51. Changing Oil in the Front PTO Reduction Gear-Box (if installed)

Screw out the plug (2) and discharge waste oil. Fill the reduction gear-box with fresh oil up to the level of the check-and-filler hole (1) (the capacity of the reduction gear-box is 3.3 l).

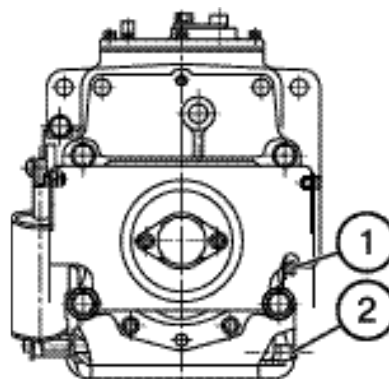

Procedure 52. Checking the Condition of the Brakes

Check the condition of brakes parts by way of their dismantling. Clean the casings from the wear and tear products, replace worn-out parts, if required, and adjust the service and parking brake control mechanism.

No scoring of the working surfaces of the pressure disks is allowed.

Procedure 53. Greasing the Bushings of the Turn Shaft of the Rear (Front) Hitch Linkage and of the Hauling Mechanism

Clean two lubricators (1) located on the bosses of the rear axle cover as well as the lubricator (2) of the towbar from dirt. Gun-grease the same till fresh grease appears from gaps.

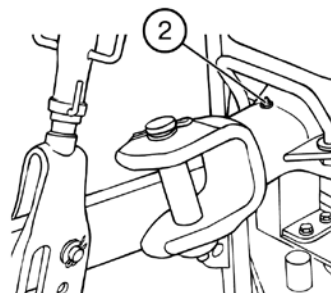
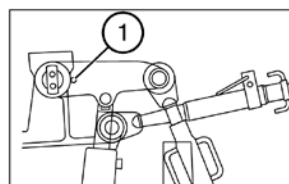

Procedure 54. Servicing the Engine Air-Cleaner

The procedure shall be performed after every 1000 hours of the engine operation as well as in case of lighting up of the pilot lamp of excessive clogging of the air filter.

To perform the servicing, proceed as follows:

- Remove the monocydon (7); clean the screen, swirler, and ejection slits from dust and dirt.
- Screw out the butterfly nut (2) and remove the pan (1).
- Remove the basic filter element (5). Pay special attention on the state of the monitor filter element (4).

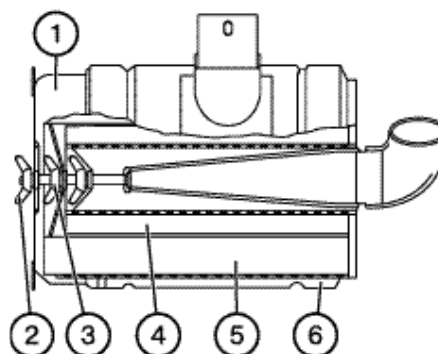

ATTENTION! Dirt and soiling of the MFE is indicative of damaged BFE (rupture of the paper shutter, unglued bottoms).

NOTE: Removing the MFE (4) from the housing (6) is not recommended.

If BFE is intact, blow it with compressed air, first from the inside and then on the outside to remove dust completely.

ATTENTION! To avoid rupture of the paper shutter, the compressed air pressure shall not exceed 0.2...0.3 MPa.

Direct the air jet at an angle to the BFE surface. Keep BFE from oiling or mechanical damage.

- If blowing is ineffective, wash the BFE in the 0.02% detergent solution. To wash the basic filter element, immerse it into the solution for ½ hours and then rinse it intensively in the same solution for 15 minutes. Wash the BFE

in clean water at 35...45°C and let it dry for 24 hours.

ATTENTION! NEVER blow BFE through with exhaust gases, **NOR** wash it in diesel fuel.

- Clean the delivery pipe, the inner surface of the housing and the pan from dust and dirt.
- Check the condition of the O-rings.
- Make sure that the BFE is installed properly in the housing; tighten the butterfly nut by hand.
- Perform Procedure 37 on the check of the air-cleaner and the intake duct leak-tightness.

Procedure 55. Checking the Steering Link Joints for Play

With the engine running, turn the steering wheel in both directions for checking the free travel and play in the joints (1) of the steering link (4).

Should there be any plays in the joints, proceed as follows:

- Remove the locking wire (3);
- Screw in the threaded plug (2) to eliminate the clearance in the articulated joint;
- Lock the plug with wire (3).

NOTE: If it is impossible to eliminate the play in the joints, disassemble the joint and replace the worn-out parts.

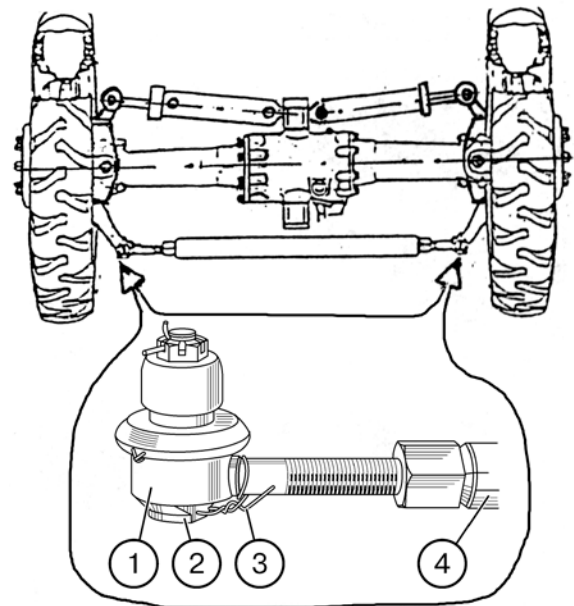

AFTER EVERY 2000 HOURS OF OPERATION perform the previous maintenance procedures plus the followings:

Procedure 56. Checking the Fuel Injection Equipment

To check the injectors for injection pressure, dismantle them from the engine by carrying out the following operations:

- screw out the coupling nuts (6) of the unions of the fuel pump and the injectors;
- remove the high-pressure pipes (4);
- remove the bolts (1) of the unions from each injector together with their sealing washers and remove the draining pipeline (3);
- screw out bolts (2) which fix the injectors and remove the injectors (5);
- send the injectors to a specialized workshop or your dealer for checking.

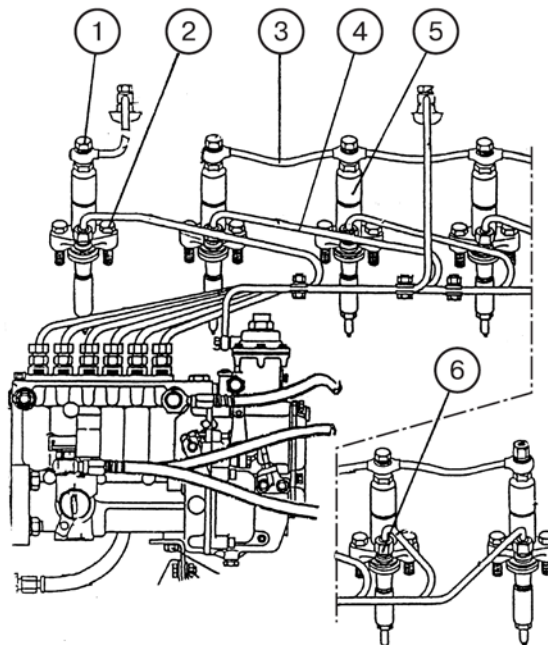

NOTE: The injection pressure should be within 22...23 MPa.* The atomization should be in the form of a mist, without continuous jets and/or drips.

Timing angles for engines Д-260.1 and Д-260.1S fitted with fuel pumps “YAZDA” or “Motorpal”, should correspond to those given in Table on the right:

To check and adjust the injectors, dismantle them from the engine and send them to a specialized workshop.

Timing angles for fuel injection (degrees to TDC)

Engine			
Д-260.1		260.1S2	
Fuel pump			
363-40.01	Motorpal	363-40.01	Motorpal
19...21	21...23	14...16**	15...17

Procedure 57. Checking the Technical Condition of the Starter

Turn out the screws (1) and remove the cap (2). Check the condition of the commutator (3), brush fittings, and easiness of movement of the brushes (5) in the brush-holders, and the pressure of the springs (4) on the brushes.

The commutator working surface shall be clean. The brush pressure shall be within 750...1000 gf.

If excessive wear and/or commutator scorching are detected, send it to a workshop for repair.

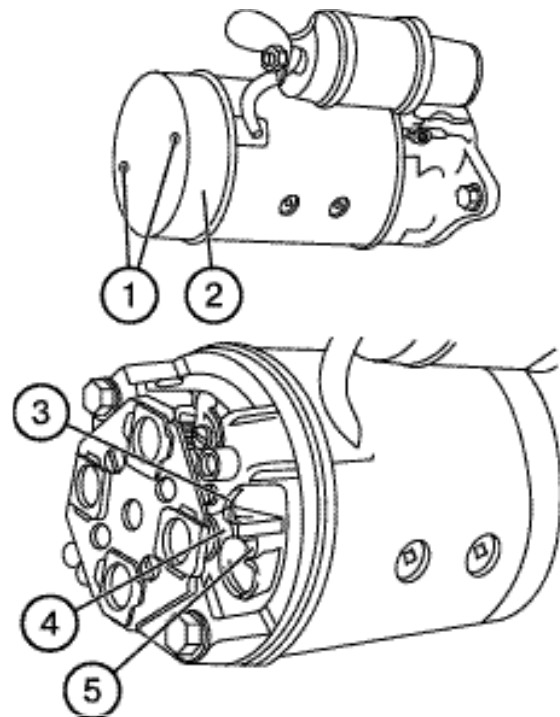

Procedure 58. Washing the Engine Breathers

- Remove the cases of the breathers (1).
- Remove the breathers from their cases.
- Wash the breathers in diesel fuel and blow them through with compressed air.
- Reassemble the breathers and refit them.

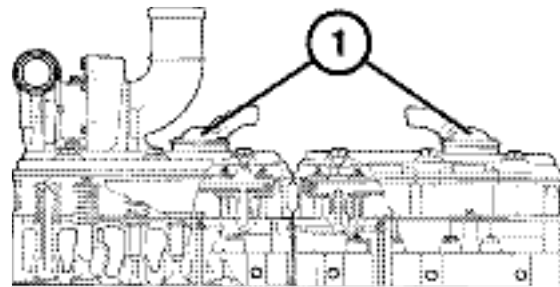

Procedure 59. Flushing the Engine Cooling System

- Prepare a solution of sodium hydroxide (50...60 g of sodium hydroxide per one litre of water);
- Add 2 litres of kerosene into the aqueous solution and fill the cooling system with this solution;
- Start the engine and let it run for 8...10 hours;
- Discharge the solution into a suitable container, flush the system with clean water and fill with coolant, as described in this Manual.

MAINTENANCE TO BE PERFORMED AS REQUIRED

Procedure 60. Adjusting the Oil Pressure in the Engine Lubrication System

If the oil pressure in the lubrication system is below 0.28 MPa on a warmed-up engine and at the rated speed of the crankshaft, stop the engine, locate and remove the trouble. Check the oil pipelines for leak-tightness and the safety valve of the oil paper filter for operability. One of the ways for increasing the pressure is slight adjustment of the filter at a specialized workshop.

Procedure 61. Adjusting the Gear-Box Centrifugal Oil Filter

The valve (2) maintains oil pressure on the GB hydraulic system to within 0.9...1.0 MPa – for the GB 16Fx8R; 0.9...1.1 MPa – for the 24Fx12R.

If pressure drops below this limit, adjust the valve by inserting additional shims (5) between the spring (3) and the plug (6).

IMPORTANT! If the pressure drops below 0.7 MPa, stop the tractor and seek help of a technician.

The valve (7) maintains oil pressure upstream of the centrifuge rotor. It shall be 0.75 MPa and can be adjusted, if required, by inserting the shims (9).

The lubrication valve (12) is adjusted to within 0.15...0.25 MPa and maintains oil pressure in the GB lubrication system. The valve is adjusted by insertion of shims (11).

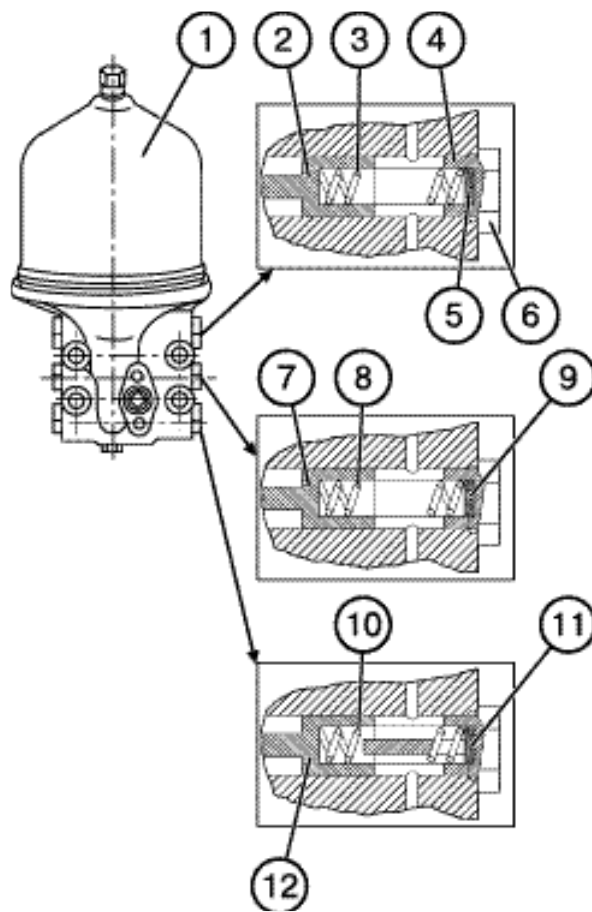

Procedure 62. Adjusting the Front Wheels Toe-In

After setting the wheel track as required, check and adjust as necessary the toe-in by changing the length of the steering link (2).

1. Set the required pressure in the tyres (refer to Table in Section "Aggregating the Tractor with Agricultural Machines and Implements", item "Allowable Loads on the Tractor Tyres Depending on the Pressure in the Tyres").
2. With the tractor placed on a flat ground, run it straight ahead several meters; then, stop the tractor and set the parking brake.
3. Measure the distance "B" behind the tractor, between two opposite points on the rim shoulder, at the height of the wheel horizontal axes.
4. Release the parking brake, and push the tractor forward, so that its wheels would turn through approximately 180°; then measure the distance "A" in front of the FDA between the same measurement points as when measuring the distance "B". The toe-in is correct, if the distance "A" is less (by 0...8 mm) than the dimension "B". If the toe-in figure exceeds the specified limits, proceed with adjustment operations, as follows:
 - Loosen the locknuts (1) and (3) of the steering link tube (2).
 - Set the required amount of toe-in by rotating the tube in either direction.
 - Tighten the locknuts (1) and (3) with applying a torque of 100...140 N·m.

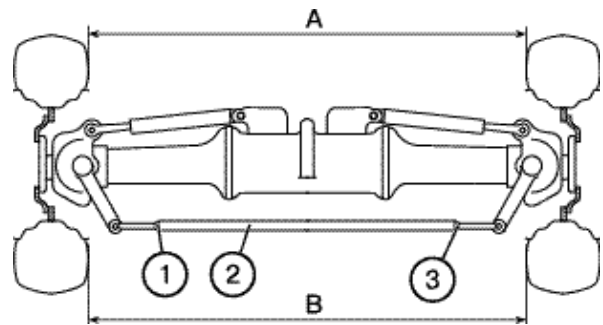

Procedure 63. Aiming External Side Headlights

- Mark out a screen, as shown in the Figure.
- Measure the distance between the headlight centres and the height of their location above the floor immediately on the tractor, the tyre pressure shall correspond to the recommended norms. Mark the headlight centre lines A-A, B-B₁, E-E₁.
- Place the tractor on a flat level ground at exactly right angle to the screen, with the front headlight lenses 15 m away therefrom. At the same time, be sure that the tractor's line of longitudinal symmetry would intersect with the screen at the line O-O₁.
- Turn on the headlights in low beam and, first, adjust the position of one headlight (block the other headlight with a dark tissue), then, the other, having loosened them on the bracket.
- The headlight is considered as correctly adjusted, if the light spot centre line D-D is at half distance from the reference surface to headlights centre-line A-A ($h/2$).

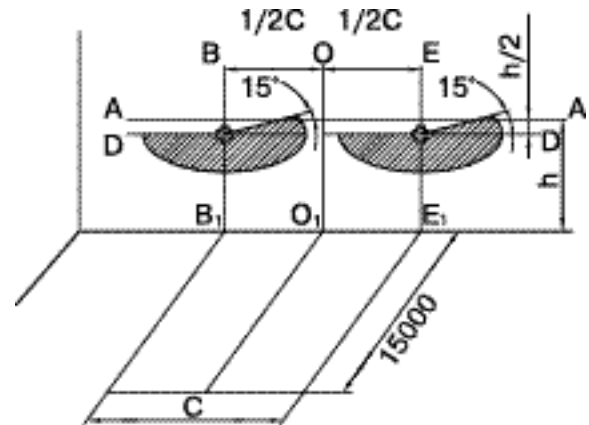

Screen marking-out and adjustment of headlights:

- A-A – headlight centre line;
- D-D – centre line of light spots;
- O-O₁ – line of symmetry of the screen;
- B-B₁ – vertical axis of a light spot from the left-hand headlight;
- E-E₁ – vertical axis of a light spot from the right-hand headlight;
- C – distance between headlight centres;
- h – distance from the floor to side headlight centre line.

Peculiarities of adjustment of the built-in headlights

- Place the tractor at the distance of 10 m from the screen to the headlight lenses.
- Perform all the operations for marking-out the screen as described above.
- The headlight beam is aimed correctly, if the location of the light spots of both headlights corresponds to the position shown in the above Figure, and the light spot centreline D-D is below the headlight centreline A-A by 150 mm.

TRACTOR STORAGE

Prior to putting the tractor for long-term storage, perform the following operations:

- Clean the tractor.
- Place the tractor under a shed or indoors.
- Gun-grease all the lubrication points:
 - FDA;
 - HPS;
 - Clutch;
 - RHL.
- Drain coolant from the engine cooling system.
- Drain oil from the engine crankcase and fuel pump body; clean the rotor of the centrifugal oil filter.
- Drain oil from the power transmission housings, HLL and HPS oil tanks the FDA hub reduction gear boxes and final drive casings. Then, refill with fresh clean oil with AKOP-1 additive.
- Fill in the engine crankcase, fuel pump body with preservation oil K-17, State Standard (ГОСТ) 10877-76 or fresh dehydrated oil with 5% AKOP-1, State Standard (ГОСТ) 15171-78 additive. Prior to using the AKOP-1 additive, mix thoroughly the engine oil and the additive.
- Start the engine and let it run for 15...30 s at low rotational speed.
- Stop the engine and drain the preservation oil from the engine crankcase and the fuel pump body.
- Discharge sediments and sludge from the fuel coarse and fine filters.
- Remove and charge storage batteries, then, put them in store in dry well-ventilated premises, with temperature of 15..20°C. Check the storage batteries once a month and recharge them, if required.
- Lower the RHL linkage to its bottom position.

- Slacken tension of the alternator and fan driving belts.
- Cover the exhaust pipe and monocyclon openings with a jacket.
- Place the tractor onto stands to relieve the front and rear tyres. Reduce the pressure in the tyres down to 70% of the normal operating value.
- During the period of storage, turn the engine crankshaft by several revolutions at least once a month.

To remove the tractor from a long-term storage, perform the following operations:

- Remove the tractor from stands and bring the pressure in the tyres to its normal value.
- Fill up fuel tanks.
- Fill in the engine with coolant and oil. Check the oil level in all the tanks/bottles to be filled up.
- Re-install fully charged storage batteries back on the tractor.
- Remove the jacket from the exhaust pipe and the monocyclon.
- Start the engine and carry out the functional checks on all the tractor instruments, controls and systems.
- Check the lighting and audible signalling devices for proper functioning.
- Run the tractor without loading to determine whether it operates properly.

APPENDICES

ADJUSTING PARAMETERS OF THE Д-260.1/Д-260.1S2 ENGINE

Description	Unit of measurement	Value
Oil pressure in a warmed-up engine lubrication system at the rated speed of the crankshaft	MPa (kgf/cm ²)	0.28-0.45 (2.8-4.5)
Coolant temperature in the cooling system	°C	80-95
Driving belt sagging at the force of 40 N (4 kgf) applied to the alternator-crankshaft side of the belt transmission	mm	29...33
Rocking arm face-to-valve stem end-face clearance on a cold engine, for::		
• admission valves	mm	0.25...0.30
• exhaust valves	mm	0.40...0.45
Injection angle setting to TDC	degrees	22±1 (16±1)* or (15±1)* or (6±1)***
Needle lift commencement pressure in the injection atomizer	MPa (kgf/cm ²)	21.6+0.8 (23.5 ^{+1.2})*** (220+8)
Tightening torques for basic threaded joints:	N•m (kgf•m)	
• cylinder head fastening bolts		190-210 (19-21)
• main bearings bolts		220-240 (22-24)
• nuts to connecting-rod bearing bolts		100-120 (10-12)
• flywheel fastening bolts		160-180 (16-18)
• counterweight fastening bolts		100-120 (10-12)
• injection fastening bolts		30-35 (3,0-3,5)**
• crankshaft pulley bolts		160-200 (16-20)
• oil centrifugal filter shell nuts		35-50 (3,5-5,0)
• torque vibration damper fastening bolts		80-100 (8-10)
• air-cleaner butterfly nuts		8-10 (0,8-1,0)

* For certified engines.

** With preliminary torque of up to 15...20 N•m (1.5...20 kgf•m).

*** For engine Д-260.1S2

Adjusting parameters of the 363.111005-40.01 fuel pump (manufactured by the YAZDA Open Joint Stock Company) to be verified on the bench

Description	Unit of measurement	Value
1. Average fuel delivery per cycle over high-pressure pipelines, at 100 rpm, at least	mm ³ /cycle	140
2. Camshaft rated rotational speed	rpm	1050±10
3. Average fuel delivery per cycle over pump high-pressure pipelines, at rated rotational speed	mm ³ /cycle	78...82
4. Fuel delivery irregularity over high-pressure pipelines, at rated rotational speed, at least	%	6
5. Rotational speed at commencement of governor control	rpm	1075±10
6. Full automatic shut-off of fuel by the governor within the speed range of	rpm	1150, max
7. Average fuel delivery per cycle by pump sections at the rotational speed of: 800 ±10 rpm	mm ³ /cycle	90...96
500 ±10 rpm		82...89
8. Pressure at pneumatic adjuster start/end action commencement/termination of operation, at n = 500 rpm	kgf/cm ²	0.1...0.2/ 0.2...0.3
9. Delivery per cycle, at rotational speed 500 rpm and no supercharged pressure	mm ³ /cycle	72...80

Note: Checking the adjustment parameters as per items 1...7 should be performed with the forced disengagement of the feedback pneumatic adjuster (i.e. the air pressure in the pneumatic adjuster shall be 0.8...1.0 kgf/cm²).

11.2a. Adjusting parameters of the PP6M10P1f-3491 fuel pump to be verified on the bench

Description	Unit of measurement	Value
1. Fuel delivery onset by geometry – by plunger motion	mm	3.5±0.05
2. Rated rotational speed of the pump shaft	min ⁻¹	1050
3. Camshaft rotational rated speed corresponding to the engine idling	min ⁻¹	400
4. Fuel delivery irregularity by pump sections, at rated speed, no more than	%	6
5. Fuel delivery irregularity by pump sections, at minimum idling, no more than	%	35
6. Pump camshaft rotational speed corresponding to fuel shut-off by the governor	min ⁻¹	1080...1090
7. Rotational speed corresponding to full shut-off of fuel delivery through injectors	min ⁻¹	1160...1170
8. Fuel delivery per cycle, at pump camshaft rotational speed of 100 rpm	mm ³ /cycle	160±6
9. Fuel delivery per cycle at rotational speed of:		
1050 rpm		90±2.0
800 rpm		92±2.5
500 rpm		75±3.6

Note: 1. The parameters of the fuel pumps should be performed using the injectors with the Motorpal DOP 119S534 atomizers.
2. The parameters as to item 9 should be checked at the supercharge pressure of 0.5 kgf/cm².

PECULIARITIES OF DISASSEMBLING AND REASSEMBLING THE ENGINE

When dismantling the engine, remove the pistons assembled with the connecting rods upwards only. Prior to removal, descale the upper part of the cylinder sleeve.

When replacing the parts of the sleeve-and-piston assembly and crank mechanism, pay special attention to their dimensional groups.

The cylinder sleeves and pistons are sorted out by their inner and skirt outer diameters, respectively, into three dimensional groups (Б – large, C – medium, M – small).

The group designation is marked on the upper sleeve shoulder and the piston crown.

Group marking	Cylinder sleeve diameter, mm	Piston skirt diameter, mm
Б (large)	110 ^{+0.06} _{+0.04}	110 ^{-0.05} _{-0.07}
C (medium)	110 ^{+0.04} _{+0.02}	110 ^{-0.07} _{-0.09}
M (small)	110 ^{+0.02}	110 ^{-0.09} _{-0.11}

Choose the pistons, connecting-rods and piston pins of the same weight

group in a set for the engine; the difference of connecting-rod weights assembled with pistons shall not exceed 30 g.

The crankshaft and crankpin necks and crankshaft bearing liners are manufactured in two nominal sizes, as follows:

Liner nominal designation	Shaft neck diameter, mm	
	main	connecting rod
1H	85.25 ^{-0.085} _{-0.104}	73.00 ^{-0.100} _{-0.119}
2H	85.00 ^{-0.085} _{-0.104}	72.75 ^{-0.100} _{-0.119}

The crankshafts, the crankshaft and crankpin necks of which are manufactured to the second nominal size, bear the following additional designation of the first web:

“2K” – crankshaft necks of the second nominal size;

“2Ш” – crankpin necks of the second nominal size;

“2KШ” – crankshaft and crankpin necks of the second nominal size.

FITTING THE PISTON RINGS

Each piston of the engine is fitted with three rings: a top compression ring (1) of a trapezoidal cross-section, second compression ring of a tapered-face and one oil-scraper ring (3) of a box-type with a spring expander. The compression tapered-face ring (2) has a marking "top" on its end-face surface near the piston-ring joint; it should face upwards to the piston crown when fitted.

The oil-scraper expander joint should not coincide with the ring joint. Locate the ring joints equidistant around the circumference.

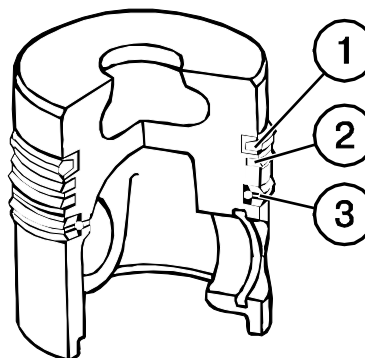

FITTING THE TIMING GEARS

The timing gears should be fitted in accordance with the marks thereon. Make the lettering on the intermediate gear (3) coincident with the corresponding marks on pinion (6) of the crankshaft and pinion (2) of the camshaft as well as with that on the gear (4) of the fuel pump drive, as shown in the figure on the right.

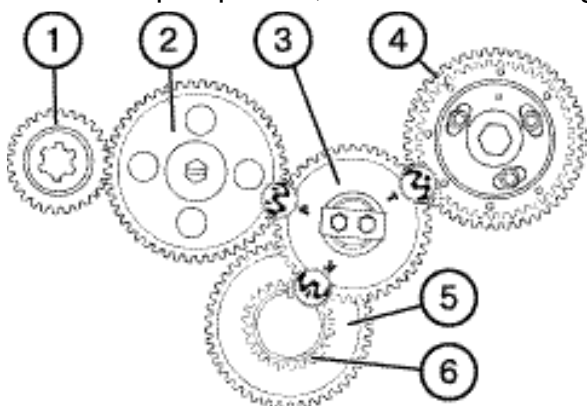

1 – HPS hydraulic pump drive gear; 2 – camshaft pinion; 3 – intermediate gear; 4 – fuel pump drive gear; 5 – oil pump driving pinion; 6 – crankshaft pinion.

PECULIARITIES OF ASSEMBLING AND ADJUSTING THE REAR AXLE FINAL DRIVES

Whenever replacement of parts and assembly units of the rear axle is required, proceed with assembly and adjustment operations in the following sequence:

- Press fit the inner race of the outer bearing (10), preheated in oil, onto the axle-shaft (9) up to the stop against the bushing (7).
- Press fit the outer bearing races (10, 11) into the housing (6) until they rest against the housing fillet.
- Install the axle-shaft assembled with the outer bearing inner race into the housing and put on the inner bearing (11) inner race.
- Slip the pinion carrier assembly (12) on the axle-shaft splines, set a washer (5) without a package of shims and tighten the bolt (4) so that the play in the axle-shaft bearings would be taken out and that the torque of axle-shaft rotation would be 3...5 N·m.
- Measure the distance from the axle-shaft to the washer outer face through the hole in the washer (5) using a slide calipers.
- Subtract the washer thickness (12 mm) from the result obtained by measurement and find the gap between the washer and the axle-shaft end-face.
- Screw out the bolt (4) remove the washer and fill in the gap with a package of shims. Fit the washer and lock-plate (3). Tighten the bolt with applying a torque of 500...550 N·m.
- Check the axle-shaft rotation torque. If it exceeds the limits stated above, increase the number of shims in the package, and vice versa.

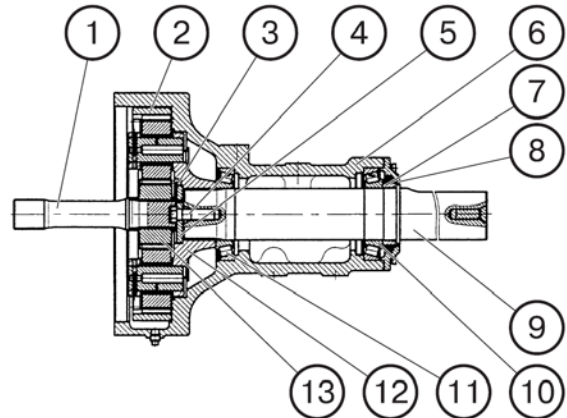

- Lock the bolt with a stopper plate having smeared preliminarily the plate surface adjacent to the washer with Litol-24 or Bechem LCP-GM grease. The plate tabs should enter the recesses in the carrier (12). If necessary, tighten the bolt slightly to align the tab with the recess. **NEVER turn out the bolt!**
- Install the crown gear (2).
- Install the planetary gear (13) assembled with the shaft (1) into the planetary drive carrier and check the gearing assembly for ease rotation.
- Fit the cover (8) and collar assembly; the collar having lubricated preliminarily the rubber ring and bearing with Litol-24 or Bechem LCP-GM grease. Tighten the cover fastening bolts.

IMPORTANT! After this adjustment the axle-shaft shall rotate with a slight drag, without jamming and/or sticking.

RECOMMENDED FUELS, OILS, LUBRICANTS, AND FLUIDS AND THEIR EQUIVALENTS

Assembly unit description	Number of assembly units	Name and designation of the fuel and lubricants				Mass (volume) of the fuel and lubricants to be poured into the tractor when being changed or replenished), kg (dm ³)	Intervals of change (replenishment) of the fuel and lubricants, hours
		Basic	Doubling	Reserve	Foreign		
1. Fuel							
Fuel tank	2	At the ambient temperature of 0°C and above				(250±1.5)	Every shift
		Diesel fuel, Belarusian Standard (СТБ) 1658-2006 with the sulphur content of not more than 350 mg/kg (0.035%) Grade C, type 1 or 2	None	Composite biological diesel fuel of the mark Б.Р.ХХ ДТЛ (ХХ – volumetric content of the biological component (rape oil) in the fuel) to the Specification ТУ BY 500048572.001-2008	Diesel fuel, EH 590:2004 with the sulphur content of not more than 350 mg/kg (0.035%)		
		At the ambient temperature of minus 20°C and above or minus 30°C and above					
		Diesel fuel, Belarusian Standard (СТБ) 1658-2006 with the sulphur content of not more than 350 mg/kg (0.035%) Grade F, type 1 or 2	None	Composite biological diesel fuel of the mark Б.Р.ХХ ДТЗ (ХХ – volumetric content of the biological component (rape oil) in the fuel) to the Specification ТУ BY 500048572.001-2008	Diesel fuel, EH 590:2004 with the sulphur content of not more than 350 mg/kg (0.035%)		
		At the ambient temperature of minus 44 °C and above					

Assembly unit description	Number of assembly units	Name and designation of the fuel and lubricants				Mass (volume) of the fuel and lubricants to be poured into the tractor when being changed or replenished) , kg (dm ³)	Intervals of change (replenishment) of the fuel and lubricants , hours
		Basic	Doubling	Reserve	Foreign		
		Diesel fuel, Belarusian Standard (СТБ) 1658-2006 with the sulphur content of not more than 350 mg/kg (0.035%) Class 4, type 1 or 2	None	None	Diesel fuel, EH 590:2004 with the sulphur content of not more than 350 mg/kg (0.035%)		
2. Oils							
Engine crankshaft	1	In summer				(18.0±0.18)	250
		Engine oil "Lukoil-Avant-garde" SAE 15W-40	Engine oils M-10ДМ, M-10Г _{2К} State Standard (ГОСТ) 8581-78	None	Castrol Turbomax SAE 15W-40 Hessol Turbo Diesel SAE 15W-40 Essolube XD-3 +Multigrate Shell Rimula TX Shell Rimula Plus Teboil Super NPD (power) Royal Triton QLT (U 76) Neste Turbo LE Mobil Delvac 1400 Super Ursa Super TD (Texaco)		
		In winter					
		Engine oil "Lukoil-Super" SAE 5W-40	Engine oils M-8ДМ, M-8Г _{2К} State Standard (ГОСТ) 8581-78	None	Shell Helix Diesel Ultra SAE 5W-40 Hessol Turbo Diesel SAE 5W-40 API CF-4		

Assembly unit description	Number of assembly units	Name and designation of the fuel and lubricants				Mass (volume) of the fuel and lubricants to be poured into the tractor when being changed or replenished), kg (dm ³)	Intervals of change (replenishment) of the fuel and lubricants, hours
		Basic	Doubling	Reserve	Foreign		
Brake housing ("wet brakes")	2	Engine oil M-10Г2 State Standard (ГОСТ) 8581-78 (summer) Engine oil M-8Г2 State Standard (ГОСТ) 8581-78 (winter)	Engine oil M-10B2 State Standard (ГОСТ) 8581-78, Engine oil M-10Г2к (summer) State Standard (ГОСТ) 8581-78 Engine oil M-8Г2к (winter) State Standard (ГОСТ) 8581-78	Engine oil, the same as in the transmission housing	Engine oil, the same as in the transmission housing	(2.5±0.1) to the level of the control plugs	1000 (500)
Transmission housing (clutch, GB and rear axle)	1	Engine oil M-10Г2 State Standard (ГОСТ) 8581-78 (summer) Engine oil M-8Г2 State Standard (ГОСТ) 8581-78 (winter)	Engine oil M-10B2 State Standard (ГОСТ) 8581-78, Engine oil M-10Г2к (summer) State Standard (ГОСТ) 8581-78 Engine oil M-8Г2к (winter) State Standard (ГОСТ) 8581-78	Engine oil, the same as in the engine crankcase	Engine oil SAE 15W-40 (in summer) SAE 5W-40 (in winter)	(43±0.4) the oil level shall be between the "П" and "П+7" marks	1000 (250)

Assembly unit description	Number of assembly units	Name and designation of the fuel and lubricants				Mass (volume) of the fuel and lubricants to be poured into the tractor when being changed or replenished), kg (dm ³)	Intervals of change (replenishment) of the fuel and lubricants, hours
		Basic	Doubling	Reserve	Foreign		
Wheel reduction gear housing of the FDA (portal, planetary spur-gear)	2	Transmission oil ТАп-15В State Standard (ГОСТ) 23652-79	Transmission oil ТАД – 17и, ТСп-15К State Standard (ГОСТ) 23652-79, ТЭП-15М ТУ 38.401-58-305-2002	None	HESSOL BECHEM HYPOID SAE 80W-90 API GL5; GL4	(4.0±0.04)	1000 or seasonal
FDA housing (portal, planetary spur-gear with a long beam)	1	Transmission oil ТАп-15В State Standard (ГОСТ) 23652-79	Transmission oil ТАД – 17и, ТСп-15К State Standard (ГОСТ) 23652-79, ТЭП-15М ТУ 38.401-58-305-2002	None	HESSOL BECHEM HYPOID SAE 80W-90 API GL5; GL4	(3.9±0.04)	1000 or seasonal
HPS reservoir with hydraulic units (hydraulic cylinder, metering pump)	1	Year-round				(9.0±0.35)	1000 or seasonal
		Industrial oil BECHEM Staroil № 32 ТУ 903.201.042-05 ADDINOL Hydraulikol HLP 32 ТУ 903.201.044-05 THK Hydraulic HLP 32 ТУ 236.915.052-08	Industrial oil ИГП-18 ТУ 38.10 1413 -97 (in winter) МГЕ-46В ТУ 38.001 347-2000 (in summer)	None	None		

Assembly unit description	Number of assembly units	Name and designation of the fuel and lubricants				Mass (volume) of the fuel and lubricants to be poured into the tractor when being changed or replenished), kg (dm ³)	Intervals of change (replenishment) of the fuel and lubricants, hours
		Basic	Doubling	Reserve	Foreign		
Front PTO reduction gear	1	Transmission oil ТАп-15В State Standard (ГОСТ) 23652-79	Transmission oil ТАД – 17и, ТСп-15К, ТСп-10 State Standard (ГОСТ) 23652-79, ТЭП-15М ТУ 38.401-58-305-2002	Engine oil M-10Г2 State Standard (ГОСТ) 8581-78	HESSOL BECHEM HYPOID SAE 80W-90 API GL5; GL4	(3.2±0.2)	1000 or seasonal
HHL with hydraulic units	1	Year-round				(30,5±0,5)	Seasonal. The application seasonality regards the operation
		Hydraulic oil BECHEM Staroil №32 ТУ 903.201.042 -05 ADDINOL Hydraulicol HLP 32 ТУ 903.201.044 -05 THK Hydraulic HLP 32 ТУ 236.915.052 -08	Industrial oil ИГП-18 ТУ 38.10 1413 -97 (in winter) МГЕ-46В ТУ 38.001 347-2000 (in summer)	None	None		
Tank	1	Year-round					

Assembly unit description	Number of assembly units	Name and designation of the fuel and lubricants				Mass (volume) of the fuel and lubricants to be poured into the tractor when being changed or replenished) , kg (dm ³)	Intervals of change (replenishment) of the fuel and lubricants , hours
		Basic	Doubling	Reserve	Foreign		
		Industrial oil BECHEM Staroil № 32 TY 903.201. 042-05 ADDINOL Hydraulikol HLP 32 TY 903.201. 044-05 THK Hydraulic HLP 32 TY 236.915. 052-08	Industrial oil ИГП-18 ТУ 38.10 1413 -97 (in winter) МГЕ-46В ТУ 38.001 347-2000 (in summer)	None	None	(13.5±0.35)	1000 or seasonal
3. Greases							
Clutch release bearing	1	Смазка Litol-24 State Standard (ГОСТ) 21150-87	BECHEM LCP-GM	Solid oil C grease State Standard (ГОСТ) 4366-76 or solid oil Ж grease State Standard (ГОСТ) 1033-79	BECHEM LCP-GM	0.02 ±0.001	250
FDA reduction gear pivot bearing	4	Смазка Litol-24 State Standard (ГОСТ) 21150-87	BECHEM LCP-GM	Solid oil C grease State Standard (ГОСТ) 4366-76 or solid oil Ж grease State Standard (ГОСТ) 1033-79	BECHEM LCP-GM	0,12 ±0.006	1000 (250)

Assembly unit description	Number of assembly units	Name and designation of the fuel and lubricants				Mass (volume) of the fuel and lubricants to be poured into the tractor when being changed or replenished), kg (dm ³)	Intervals of change (replenishment) of the fuel and lubricants, hours
		Basic	Doubling	Reserve	Foreign		
Universal joint of the hydraulic cylinder of the steering control	4	Grease Litol-24 State Standard (ГОСТ) 21150-87	BECHEM LCP-GM	None	BECHEM LCP-GM	0.05 ±0.003	250
RHL turning shaft bushing 6)	2	Grease Litol-24 State Standard (ГОСТ) 21150-87	BECHEM LCP-GM	Solid oil C grease State Standard (ГОСТ) 4366-76 or solid oil Ж grease State Standard (ГОСТ) 1033-79	BECHEM LCP-GM	0.02 ±0.001	500
4. Special fluids							
Reservoir of the hydraulic actuator of the clutch and cylinders (for the BELARUS-1523B/1523B.3 tractor)	2	Neva M brake fluid TY 2451-053-36732629-2003	None	None	DOT3, DOT4 (Germany)	(0.8±0.2)	1000 (8-10)
Reservoir of the hydraulic actuator of the brakes and cylinders	3	Neva M brake fluid TY 2451-053-36732629-2003	None	None	DOT3; DOT4 (Germany)	(1.2±0.3)	1000 (500)

Assembly unit description	Number of assembly units	Name and designation of the fuel and lubricants				Mass (volume) of the fuel and lubricants to be poured into the tractor when being changed or replenished), kg (dm ³)	Intervals of change (replenishment) of the fuel and lubricants, hours
		Basic	Doubling	Reserve	Foreign		
Cooling system of the MMZ diesel engines (with radiator)	1	<p>“Dzerzhinsk Tosol TC-40” low-freezing coolant (down to minus 40°C), “Dzerzhinsk Tosol TC-65” (down to minus 65°C) Specification TY 2422-050-36732629-2003.</p> <p>OЖ-40 low-freezing coolant (down to minus 40°C) State Standard (ГОСТ) 28084-89.</p> <p>“Sibur Premium” low-freezing coolant OЖ-40 (down to minus 40°C), OЖ-65 (down to minus 65°C) TY 2422-054-52470175-2006</p>	<p>OЖ-40 coolant (down to minus 40°C), OЖ-65 coolant (down to minus 65°C), State Standard (ГОСТ) 28084-89</p>	None	<p>MIL-F-5559 (BS 150), (CWA) FL-3 Sort S-735, (England)</p>	(33.5±0.5)	Once 2 years

Electric Wiring Diagram of the Tractor

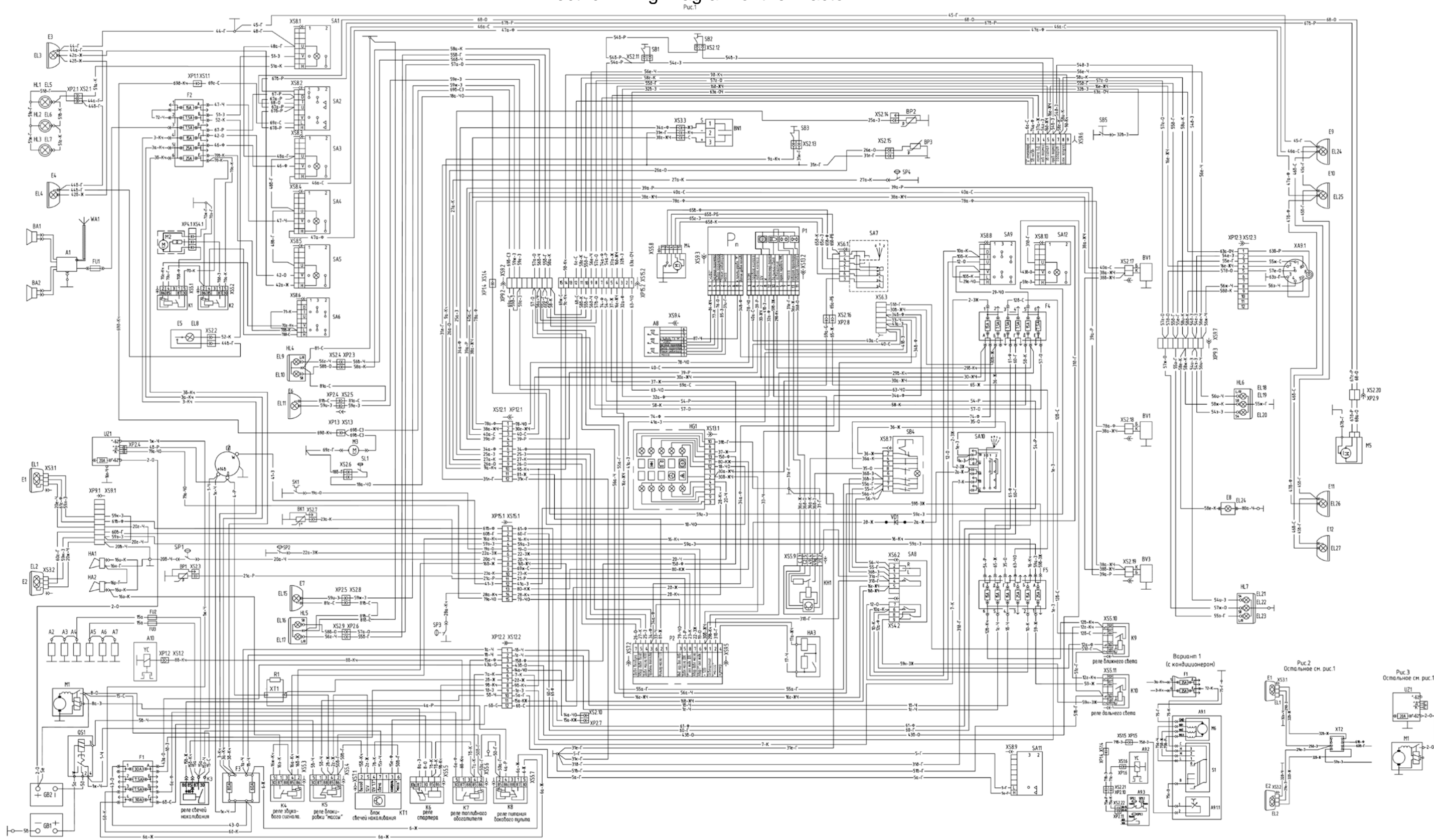

Wire colouring: Г – blue, Ж – yellow, З – green, К – red, Кч – brown, Р – pink, С – grey, О – orange, Ф – violet, Ч – black, ЖЧ – yellow-black, КЖ – red-yellow, ЗЖ – green-yellow, ОЧ – orange-black

«Д» генератора	"D" of the alternator
12 В <Кл.58>	12 V <Terminal 58>
лампа БД	Differential lockup
лев. тормоз	Left-hand brake
Зв. сигнал	Horn
прав. тормоз	Right-hand brake
габарит	Side lamp
Блок запуска	Starting unit
Значение параметра	Parameter value
Выбор параметра	Parameter selection
Режим индикации	Indication mode
масса	Frame earth
к пульту управл. «М»	to the control panel "M"
датчик уровня топлива	Fuel level gauge
ВОМ	Power takeoff shaft
правое колесо	Right-hand wheel
левое колесо	Left-hand wheel
стояночный тормоз	Parking brake
дальний свет	High beam
освещение	Lighting
перекл. передачи HML	HML gear shifting
поворот трактора	Tractor turning
поворот прицепа	Trailer turning
к выводу ТХ «М»	To the TX "M" outlet
давл. воздуха	Air pressure
Авар. давл. возд.	Emergency air pressure
Давл. масла КПП	GB oil pressure
Уровень топлива	Fuel level
Фильтр масла ГСП	ГСП oil filter
Инд. зар. доп. АКБ	Additional storage battery charge indicator
Давл. масла ДВС	Engine oil pressure
t° охл. жидк. ДВС	Engine coolant temperature
Авар. давл. масла	Emergency oil pressure
Авар. t° охл. жидк.	Emergency coolant temperature
+12 В	+12 V
Освещение	Lighting
зуммер	Buzzer
реле ближнего света	Low beam relay
реле дальнего света	High beam relay
Вариант 1	Variant 1
(с кондиционером)	(with air-conditioner)
Рис. 2 (3)	Figure 2 (3)
Остальное см. рис. 1	For other details see Figure 1
Реле свечей накаливания	Glow plug relay
Реле звукового сигнала	Horn relay
Реле блокировки «массы»	Frame earth interlock relay
Блок свечей накаливания	Glow plug block
- выход	- outlet
- свеча	- plug
- контроль	- control
Реле стартера	Starter solenoid switch
Реле топливного обогатителя	Fuel dresser relay
Реле питания бокового пульты	Side panel supply relay

List of elements to the electric diagram

Designation	Description
A1	Radio-stereo tape recorder
BA1, BA2	Speaker
FU1	Fuse
A2...A7	Glow plugs
A8	Tachospeedometer control panel
A9	Air-conditioner
A9.1	Air-processing unit
A9.1.1	Outlet air temperature regulator
M6	Fan motor
S1	Fan mode switch
A9.2	Compressor and condenser unit
YC	Electromagnetic clutch of the compressor
A9.3	Block of pressure sensors
SP9.1	Minimum pressure sensor
SP9.2	Maximum pressure sensor
SP9.3	Maximum pressure sensor
A10	Fuel dresser valve
A11	Fuel consumption registration system
BK1	Temperature gauge sensor
BN1	Fuel volume sensor (frequency-type) ДОТ.6804-01
BP1	Engine oil pressure sensor
BP2	GB oil pressure sensor
BP3	Air pressure sensor
BV1...BV3	Speed sensor
E1, E2	Road headlight
E3, E4, E6 E7, E9... E12	Working floodlight
E5	Cab lighting lamp
E8	Number plate light
EL1, EL2	Lamp АКГ12-60+55-1
EL7...EL9, EL13, EL16, EL 24	Lamp A12-5
EL19, EL22	Lamp A12-10
EL10, EL12, EL17, EL18, EL20, EL21, EL23	Lamp A12-21-3
EL5, EL6, EL14, EL15, EL25...EL28	Lamp АКГ12-55-1
F1...F5	Fuse block
FU1	Fuse link 2 A
FU2, FU3	Fuse link 25 A
G1	Alternator 14 V, 150 A
GB1, GB2	Storage battery 12/120.
HA1	Low-tone horn
HA2	High-tone horn
HA3	Audible alarm relay
HG1	Pilot lamp unit
HL1...HL3	Road train light
HL4, HL5	Front light
HL6, HL7	Rear light
K1, K2, K4, K7...K10	NO relay 30 A
K3	Glow plug relay
K5	NC relay 20A

Designation	Description
K6	Starter solenoid switch
KH1	Turn indicator flasher unit
KT1	Glow plug unit
M1	Starter 24 V, 5.5 kW
M2	Heater fan
M3	Electric washer
M4	Pantograph-type windscreen wiper
M5	Windscreen wiper
P1	Combined indicator
P2, P3	Instrument cluster
QS1	Remote battery disconnect switch 24 V
R1	Additional resistor СД-3 (50 Ω, 5 W)
SA1	Road train sign switch
SA2	Windscreen wiper and washer switch
SA3	Switch of the working floodlights (external rear ones on the roof)
SA4	Switch of the working floodlights (internal rear ones on the roof)
SA5	Switch of the working floodlights (front on the roof)
SA6	Fan switch
SA7	Windscreen wiper switch
SA8	Multi-function control stalk
SA9	Central light switch
SA10	Starter switch with interlocking of starting
SA11	Battery disconnect switch
SA12	Switch of the working floodlights (on the handrail)
SB1, SB2	Stop signal switch
SB3	Starting interlock switch
SB4	Fault signalling pushbutton
SB5	Parking brake lamp switch
SK1	Emergency temperature sensor
SL1	Emergency brake fluid level sensor
SP1	Air cleaner filter clogging sensor
SP2	Emergency oil pressure sensor
SP3	Emergency oil pressure sensor (in the HPS)
SP4	Emergency air pressure sensor
UZ1	Voltage transformer
XA9.1	Socket for connecting the agricultural implements
XP1.1...XP1.7	Terminal block 502601
XP2.1...XP2.11	Terminal block 502602
XP4.1	Terminal block 502604
XP6.1	Terminal block 502606
XP9.1...XP9.3	Terminal block 1-480673-0
XP12.1, XP12.3	Plug ШС32П12Ш-MT-7
XP12.2	Plug ШС32ПК12Ш-MT-7
XP15.1, XP15.2	Plug ШС36ПК15Ш-MT-6
XS1.1...XS1.7	Terminal block 602601
XS2.1...XS2.4,	Terminal block 602602

Designation	Description
XS2.6, XS2.7XS2.9...X S2.11, XS2.17, XS2.22	
XS2.5, XS2.8, X S2.12...XS2.16, XS2.18...XS2.2 1	Terminal block 601202
XS3.1 ... XS3.3	Terminal block 601203
XS4.1, XS4.2	Terminal block 602604
XS5.1...XS5.11	Terminal block 607605
XS6.1...XS6.2	Terminal block 602606
XS6.3	Terminal block 602606-XX-10
XS6.4	Terminal block 1-965640-1
XS7.1, XS7.2	Terminal block 602207
XS8.1...XS8.6X S8.8, XS8.9	Terminal block 605608

Designation	Description
XS8.7	Terminal block 610608
XS9.1, XS9.2, XS9.7	Terminal block 1-480673-0 (AMP)
XS9.3...XS9.6	Terminal block 602209
XS10.1	Terminal block 1-0967240-1
XS12.1, XS12.3	Socket ШС32УК12Г-MT-7
XS12.2	Socket ШС32П12Г-MT-7
XS13.1	Terminal block 602213
XS15.1	Socket ШС36П15Г-M-6
XS15.2	Socket ШС36У15Г-M-6
XT1	Two-contact connecting panel
XT2	Dividing box
VD1	Rectifying diode
WA1	Antenna

Electric Connection Diagram of the LD, FDA and GB Reduction Gear Control Systems

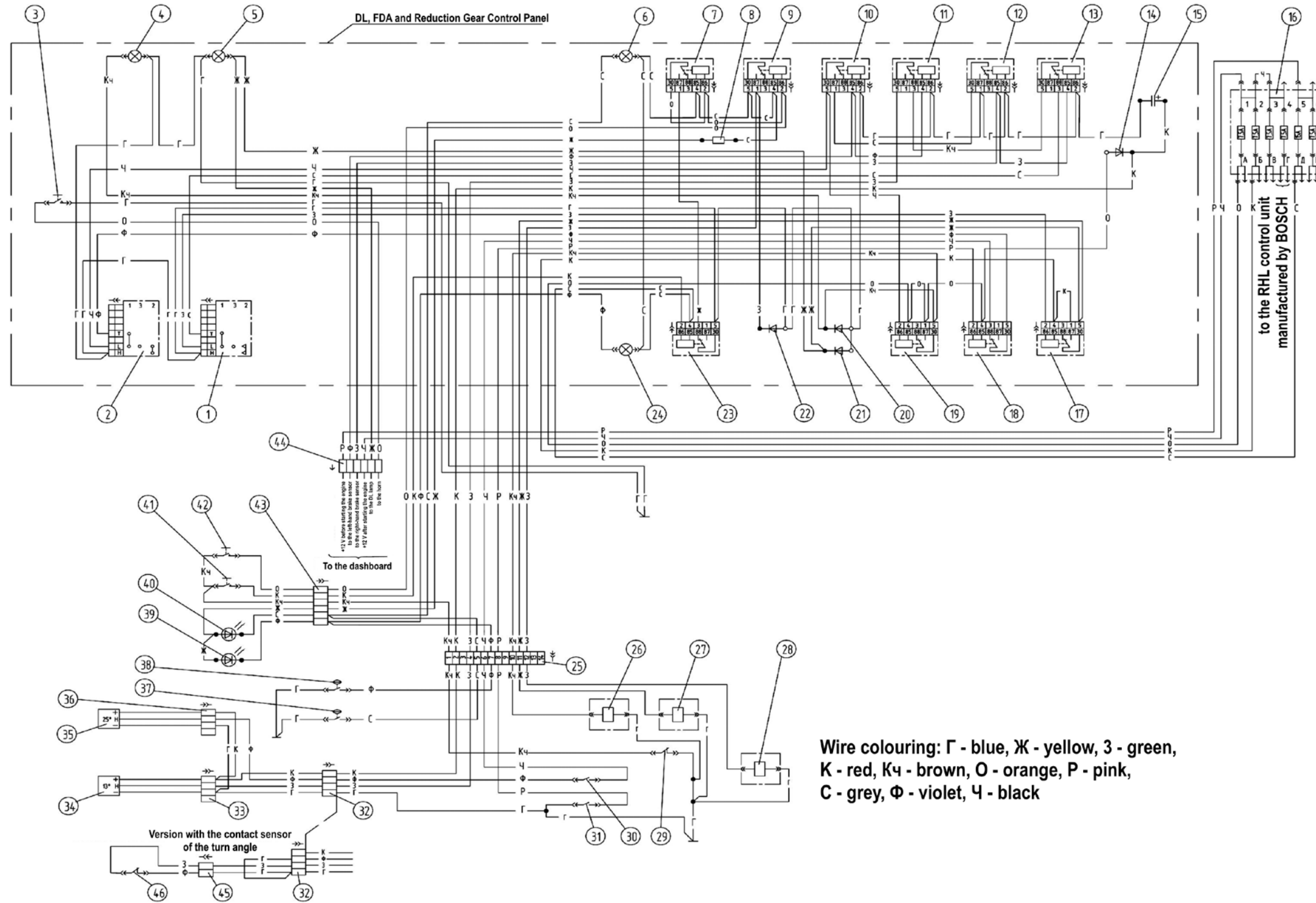

- 1 – Differential lock control switch;
- 2 – FDA drive control switch;
- 3 – Horn pad;
- 4 – FDA drive engagement warning lamp;
- 5 – Differential lock engagement warning lamp;
- 6 – GB reduction gear higher stage warning lamp;
- 7, 9 – GB reduction gear higher stage engagement relay;
- 8 – Resistor;
- 10, 11 – Left-hand brake relay;
- 12, 13 – Right-hand brake relay;
- 14, 20, 21, 22 – Diodes;
- 15 – Capacitor;
- 16 – Fuse block;
- 17 – Differential lock engagement relay;
- 18 – Reverse relay;
- 19 – FDA drive engagement relay;
- 23 – GB reduction gear lower stage engagement relay;
- 24 – GB reduction gear lower stage engagement relay;
- 25 – Socket connector;
- 26 – FDA hydraulic distributor electromagnet;
- 27 – Electromagnet of the hydraulic distributor of the differential lock;
- 28 – Electromagnet of the hydraulic distributor of the Gearbox reduction gear;
- 29 – GB neutral sensor;
- 30 – Sensor of automatic control of the FDA drive;
- 31 – Reverse sensor;
- 32, 33, 36, 43, 44, 45 – connecting blocks;
- 34 – Contactless sensor of the angle of turning of the front wheels of $\pm 13^\circ$ (for the DL);
- 35 – Contactless sensor of the angle of turning of the front wheels of $\pm 25^\circ$ (for FDA);
- 37 – Pressure sensor of the GB reduction gear higher stage;
- 38 – Pressure sensor of the GB reduction gear lower stage;
- 39 – LED of signalling of the GB reduction gear lower stage;
- 40 – LED of signalling of the GB reduction gear higher stage;
- 41 – Pushbutton for engaging the GB reduction gear lower stage;
- 42 – Pushbutton for engaging the GB reduction gear higher stage;
- 46 – Contact sensor of turning of the front wheels $\pm 13^\circ$ (for the DL).

Electric Connection Diagram of the Front PTO Control System

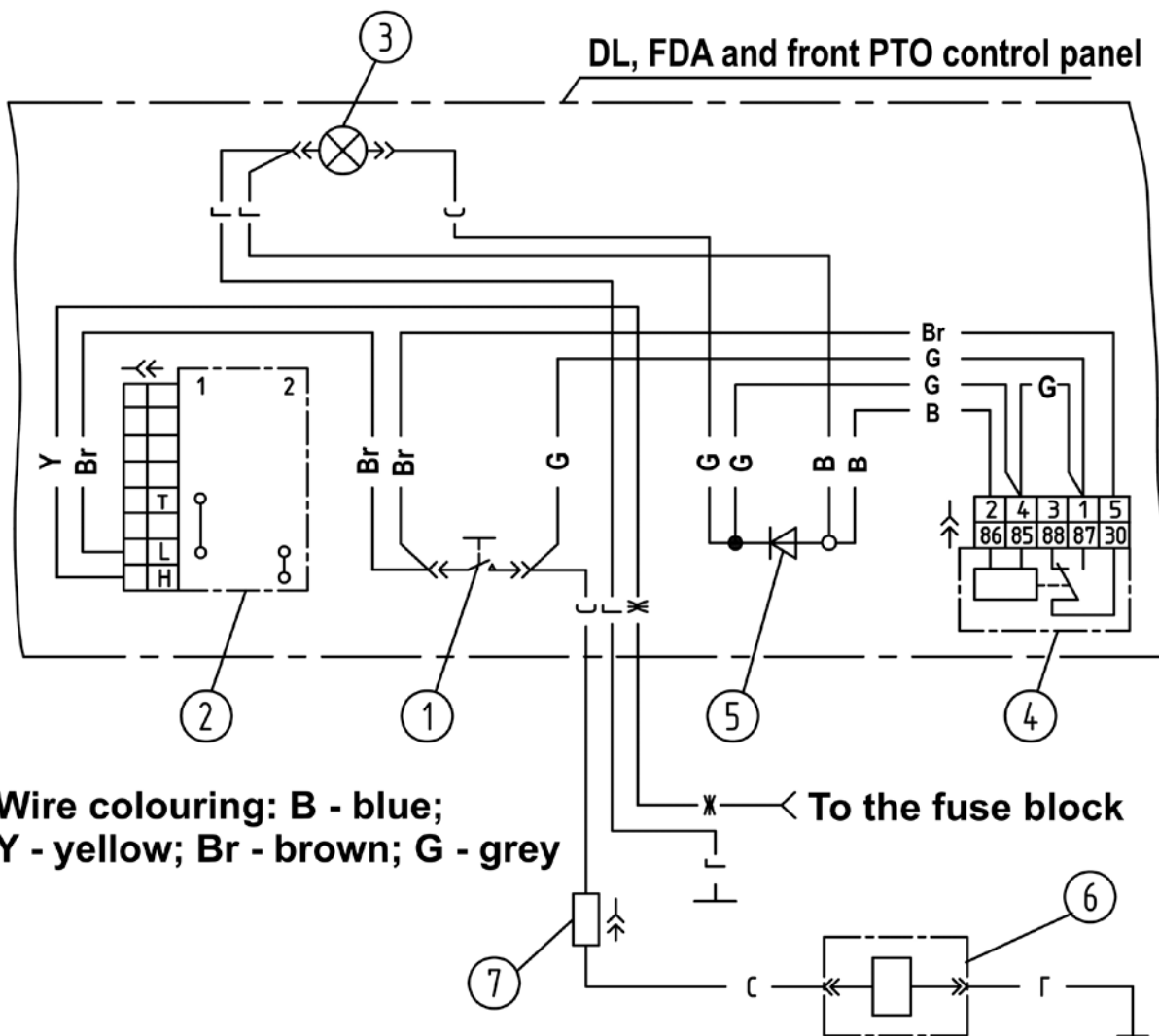

- 1 – Switch of engagement/disengagement of the front PTO;
- 2 – Two-position switch of the front PTO;
- 3 – Front PTO signalling lamp;
- 4 – Front PTO engagement relay;
- 5 – Diode;
- 6 – Electromagnet of the hydraulic distributor of the front PTO;
- 7 – Connecting block.

Electric Connection Diagram of the RHL with the Electronic Components Manufactured by the BOSCH Company

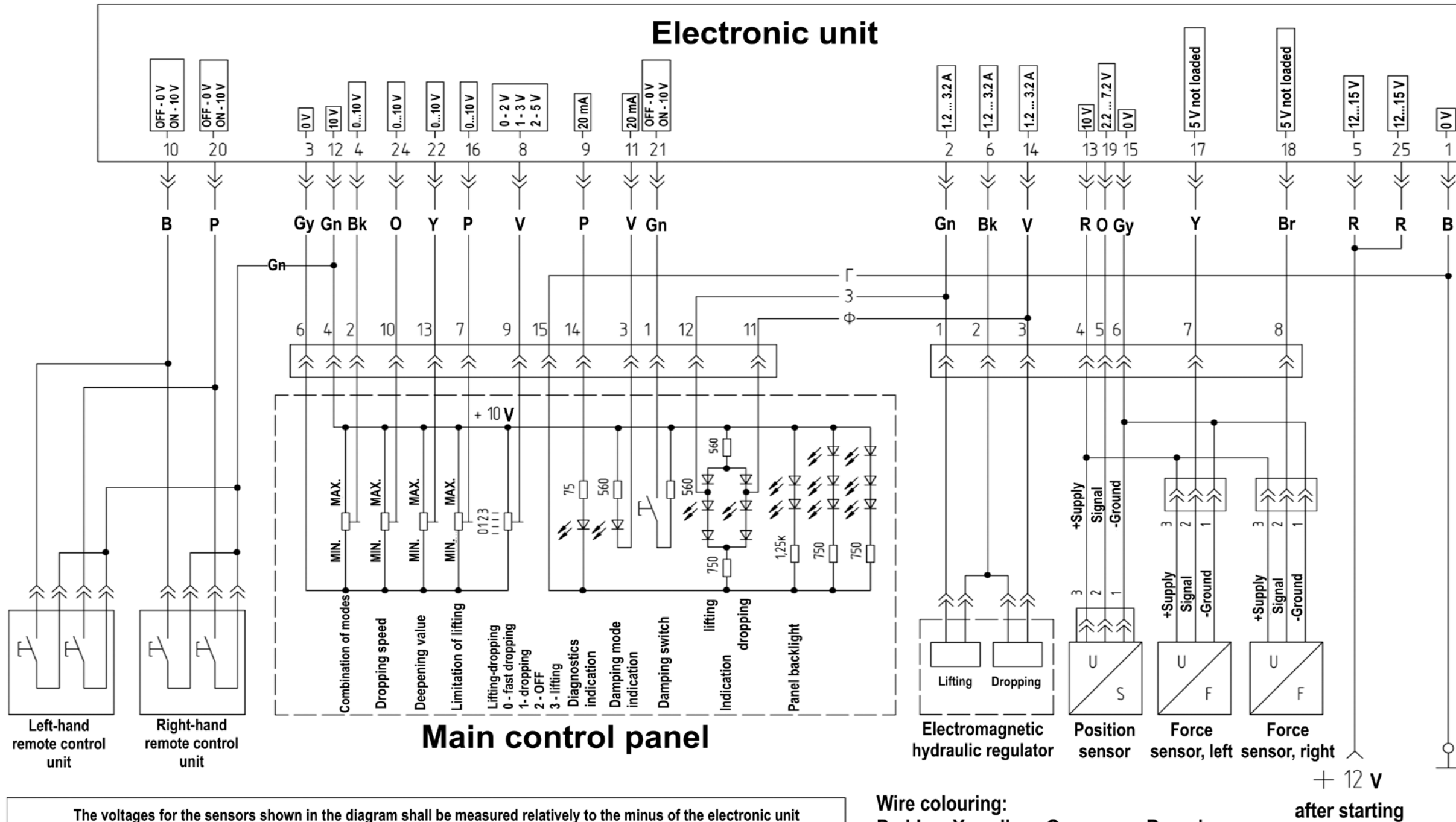

The voltages for the sensors shown in the diagram shall be measured relatively to the minus of the electronic unit (terminal 15 in the 25-contact connector), the remaining voltages - relatively to the minus of the power supply unit (terminal 1)

Electric Connection Diagram of the RHL with the Electronic Components Manufactured by the Izmeritel Plant

